

Cellular Network Interface-2e

CNI2e-H and CNI2e-C

Operating Guide

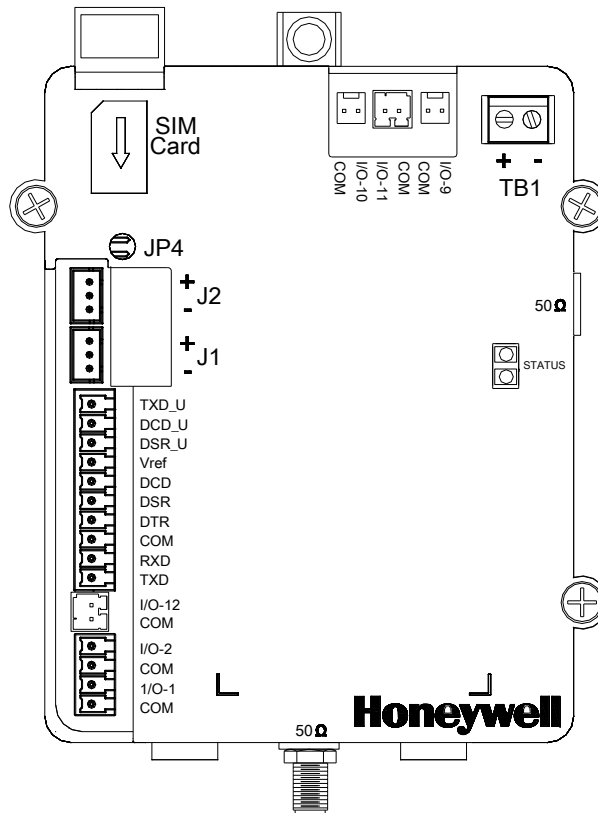

Issued: July, 2016

V 1.3

Contents

REVISION HISTORY	12
TRADEMARKS AND COPYRIGHTS	13
HISTORICAL REFERENCES	13
SYMBOLS	14
IMPORTANT BATTERY INFORMATION	16
OVERVIEW	17
FEATURES	17
CNI2E-H CERTIFICATIONS	17
CNI2E-C CERTIFICATIONS	17
SLEEVE ASSEMBLY	18
CNI2e-H Assembly.....	19
CNI2e-C Assembly.....	20
Location of the Cover Fasteners.....	21
Metrological Sealing.....	22
Location of Antenna Connectors.....	24
Installation of the SIM Card.....	27
Location of Power Inputs	28
Use of a Super Capacitor.....	29
CNI2e-H Label	31
CNI2e-C Label	32
OUTDOOR ENCLOSURE	33
INSTRUMENT MOUNTING OPTIONS	34
Wall Mounting	34
Vertical Pipe Mounting	35
Index Mounting.....	36
ENCLOSURE SEALING	43
TAMPER DETECT & CALL SWITCH OPTIONS	44
INTERNAL BATTERIES	45
RESERVE CAPACITOR	48
AC-POWER WITH BATTERY BACKUP	49
AC POWER SUPPLY REQUIREMENTS	49
AC POWER SUPPLY RECOMMENDATIONS.....	49
SOLAR POWER CONFIGURATION	52
ELECTRICAL ASSEMBLIES	56
CNI2E-H CIRCUIT BOARD	56
Cellular Radio Module.....	57
SIM Card Socket.....	57
Reset Jumper JP4.....	57
Power Connectors J1 & J2	57
Terminal Block TB1	57
Terminal Block TB4.....	57
Terminal Block TB2.....	57
Terminal Block TB3.....	57
Connector J5.....	58
Connector J4.....	58
Connector J7	58
Connector J6.....	58
Jumper JP2	58
JP3 Jumper Settings	59

CNI2E-C CIRCUIT BOARD	60
Cellular Radio Module.....	61
SIM Card Socket.....	61
Reset Jumper JP4.....	61
Power Connectors J1 & J2	61
Terminal Block TB1.....	61
Terminal Block TB2.....	61
Terminal Block TB4.....	61
Connectors J7 and J11	62
Connectors J9 and J12	62
JP3 Jumper Settings	62
JP6 Jumper Settings	63
DIGITAL SIGNAL INPUTS & OUTPUTS	64
Alarm / Pulse Inputs.....	64
Alarm Input Assignments as a Metretek SIP or InvisiConnect Device	64
Outputs.....	65
EXTENDING BATTERY LIFE	66
LOW BATTERY DETECTION.....	66
SERIAL PORT CONNECTIONS.....	67
PROGRAMMING INFORMATION.....	68
CONFIGURING THE PROGRAMMING PORT	70
Starting the Programming Application	71
MAIN SCREEN	73
Saving and Retrieving Configurations.....	73
Remote Unit ID (RUID)	73
Primary Destination.....	73
Originate Calls.....	74
Allow Connection Requests	74
Respond to Voice Calls / Respond to SMS	74
Time Interval Size	74
Firmware Version	75
Compare Device Configuration to Template.....	75
INPUT / OUTPUT CONFIGURATION	76
Alarm Input Parameters	76
“Special Purpose” Input Parameters.....	78
Pulse-Counting Input Parameters.....	80
Output Parameters.....	83
Output Under Host Control.....	83
Output Follows Input	83
“Special Purpose” Output.....	85
OPTIONS SCREEN	86
Applications Selection	86
Metretek SIP	87
Metretek SIP via InvisiConnect	87
Metretek InvisiConnect.....	87
Mercury MINI-MAX or Mercury Pulse Accumulator	87
SMS Modem	88
Transparent Modem.....	88
Allow Transparent Mode	88
When Answering if No Port Select.....	89
Low Battery Alarm.....	90
Queue Size	91
Queue Full Alarm	91
Sample Rates.....	91
SERIAL PORT CONFIGURATION SCREEN	92

Port Select ID	92
Port Enable	92
Max BPS, Data Bits, Parity, Stop Bits	92
Flow Control	93
Hardware Handshaking	93
Software Handshaking	94
No (None) Handshaking	94
RS-485 Half Duplex	94
Delay before Sending Packets	94
Listening Port	95
Always Send CONNECT Message	95
Always "RING" Port	95
Use Non-verbose Result Codes	96
Enable Blocking	96
Use Alternate CONNECT Message	96
Connect on DTR High	96
Disconnect on DTR Low	97
CELLULAR SETTINGS SCREEN	98
"SIP" Versus "MIP"	98
"Dynamic" Versus "Static" IP Addresses	98
CDMA Service (CNI2e-C only)	99
CDMA Packet (Internet) Service	99
CDMA Circuit Switched Data (CSD) Service	99
Over-the-Air-Activation (OTAA)	100
OTAA Programming Number	101
Packet Service Connection Command	102
Session Timeout	102
Ping Interval	102
Source Port Starting / Ending Numbers	102
PAP User Name and Password	103
Maximum Packet Size	103
Destination Baud Rate	104
Notes about using Aeris Cellular Service	104
GSM (2G) SERVICE (CNI2E-H ONLY)	105
WCDMA (3G) SERVICE (CNI2E-H ONLY)	105
GSM and HSPA Packet (Internet) Service	105
GSM and HSPA Circuit Switched Data (CSD) Service	106
Installation of the SIM Card	107
Service Type	108
Access Point Name	109
Packet Service Connection Command	109
Session Timeout	109
Ping Interval	109
Source Port Starting / Ending Numbers	110
PAP User Name and Password	110
PIN Number	111
Maximum Packet Size	111
Destination Baud Rate	111
CALL SCHEDULING SCREEN	113
Call Retry Strategy	113
Primary Call Retry Count	113
Primary Call Retry Interval	114
Secondary Call Retry Interval	114
Try Alternate Destination	114
Enable Repetitive Call Schedule	114
Special Retry Strategy for Unique InvisiConnect Applications	115

SERVER MODE	117
“Servers” and “Clients”	117
Server Mode Requirements	117
Server Mode Security.....	118
Server Mode Start / End Options	118
Server Mode LED Indicators	118
Configuring the CNI2e for Server Mode.....	119
Allow Connection Requests	120
Modem (CNI2e) Listening Port Number.....	120
Friends List.....	121
Hardware-Triggered Server Mode	121
ATD Command-Triggered Server Mode	123
Scheduled Server Mode.....	124
How Does the CNI2e Know What Day It Is?.....	124
Specifying an Alternate Time Server	125
Other Methods of Obtaining the Current Time and Date	126
Daylight Savings Time (DST) adjustment	127
Time Zone Adjustment	127
Early Termination of a Server Session	129
Interruption of a Server Session	130
Connections to a Specific Serial Port.....	131
PROGRAMMING THE CNI2E	132
Loading a Configuration with the Programming Cable	132
OVER-THE-AIR (OTA) PROGRAMMING.....	133
What is Over-the-Air Programming?	133
Over-the-Air Configuration Changes Using PowerSpring®	133
Over-the-Air “Firmware” Changes Using PowerSpring®	135
Over-the-Air Configuration Changes Using InvisiConnect®	136
Over-the-Air Firmware Changes Using InvisiConnect®	137
MERCURY INSTRUMENTS EMULATION	139
WHAT ARE ITEM CODES?	139
DIFFERENCES BETWEEN METRETEK AND MERCURY DEVICES	139
WRITE-PROTECTED ITEM CODES.....	140
ITEM CODES PROTECTED BY ITEM-139.....	141
MULTIPLE ACCESS ITEM CODES	142
SERVER MODE (“CALL-OUT”) ITEM CODES	143
Item-487 (Call-in Keep Alive Time)	144
Item-488 (Call-out Repeat Interval).....	144
Item-490 (Call-out Start Time)	144
Item-485 (Call-out Stop Time).....	144
Item-489 (Call-out Keep Alive Time).....	144
How Changes to Call-Out Items Affect MP32’s Server Mode Settings	145
How Changes to MP32’s Server Mode Setting Affect the Call-Out Item Codes	147
MEASUREMENT (PULSE-COUNTING) ITEM CODES	148
What are “Volume Unit” Item Codes?	150
What are “Pulse Value” Item Codes?	151
What is the “Energy Unit” Item Code?	152
What are “Scaling Factor” Item Codes?.....	152
What is the “Energy Value” Item Code?	152
How are Pulse Counts Converted and Corrected?.....	153
THE AUDIT TRAIL SIZE	155
THE “T&A” AND “T&A2” EVENT RECORDS	156
“FIRST-TIME” ITEM CODE DEFAULT VALUES	158
RESET ITEM CODE DEFAULT VALUES.....	159
PROGRAMMING THE ITEM CODES.....	161

Local Programming	161
Remote Programming	161
TRANSPARENT MODEM OPERATION	162
POWER PRESERVATION MODE.....	164
Configuring the CNI2e-C for Power Preservation Mode.....	165
Configuring the CNI2e-H for Power Preservation Mode.....	166
TRIGGERING POWER PRESERVATION MODE WITH THE LOW-BATTERY ALARM SET POINT	167
TRIGGERING POWER PRESERVATION MODE WITH A HARDWARE INPUT	168
Configuring Metretek SIP or InvisiConnect Devices	170
Configuring Mercury PA or Mini-Max Devices	171
LED STATUS INDICATORS	172
CALL PROGRESS AND STATUS (CLIENT MODE).....	172
LED ERROR CODES	173
LEDS AFTER OVER-THE-AIR REPROGRAMMING	181
TECHNICAL INFORMATION	182
“SAMPLE RATE” EXPLAINED	182
“DEBOUNCE” EXPLAINED	182
What is Switch “Bounce”?	182
What is “Debouncing”?	183
FORM-C OPERATION.....	184
USING THE OUTPUTS	185
OUTPUT SIGNAL POLARITIES.....	185
OUTPUT-FOLLOWS-INPUT	186
OUTPUT-FOLLOWS-INPUT ACCURACY ERRORS.....	186
OUTPUT-FOLLOWS-INPUT DELAY ERRORS	186
CONVERTING A DIGITAL OUTPUT TO DRY CONTACT.....	187
USING THE OPEN-COLLECTOR OUTPUT ON THE CNI2e-H	190
AT MODEM EMULATION MODE	191
ATV (response type) Command	192
ATE (echo) Command	192
ATH (hangup) Command.....	192
ATZ (reset) Command	192
ATA (answer) Command	192
ATD (dial) Command	192
+++ (escape) Command	193
AT Command Chaining.....	193
AT+ICLK? (time and date) Command	193
AT+TOTALS? Command.....	194
Response to AT Commands while in SLEEP Mode	195
POWERSPRING (DC-2009) DATA COLLECTION SOFTWARE SETUP FOR METRETEK	
“SIP” MODE.....	196
INTRODUCTION.....	196
SETTING UP THE SIP SERVER FOR PACKET (INTERNET) CONNECTIONS	196
SETTING UP POWERSPRING FOR CSD CONNECTIONS	198
SETTING UP A CALL SCHEDULE.....	200
DEFINING THE CNI2E – MANUAL MODE	203
CONFIGURING THE CNI2E	206
CONFIGURING THE CNI2E’S PULSE-COUNTING INPUTS.....	207
CONFIGURING THE CNI2E’S CALL INFORMATION	209
CONFIGURING THE CNI2E’S ALARMS.....	210
Customer Alarm-1	211

Customer Alarm-2	211
Magnetic or "CALL" Switch Alarm	211
TAMPER Detect Alarm	212
AC-OFF Alarm	212
AC-ON Alarm	212
KYZ4 Alarm	212
Unit Reset Alarm	212
Call Retry Alarm	212
Queue Full Alarm	212
Clock Resync Alarm	212
Remote Daily Volume Low Input-1,2,3,4	213
Remote Daily Volume High Input-1,2,3,4	213
Remote TTI Consumption Low Input-1,2,3,4	213
Remote TTI Consumption High Input-1,2,3,4	213
Low Battery Alarm	213
DEFINING THE CNI2E – AUTOMATIC MODE	214
STARTING POWERSPRING	214
OBTAINING THE CNI2E'S CELLULAR PHONE NUMBER	214
OBTAINING THE CNI2E'S HARDWARE STATUS AND CELLULAR INFORMATION	215
TROUBLESHOOTING GUIDE	220
HARDWARE ALARM-SENSING	220
PULSE-COUNTING	221
POWER SOURCE	222
NETWORK LOW-SIGNAL PROBLEMS	223
NETWORK CONNECTION PROBLEMS (CLIENT MODE)	224
NETWORK CONNECTION PROBLEMS (SERVER MODE)	225
SERIAL PORT	227
CSA CONTROL / INSTALLATION DRAWINGS	229
ESD HANDLING PRECAUTIONS	236
SPECIFICATIONS	237
CERTIFICATIONS	237
CELLULAR CARRIER CERTIFICATIONS	237
MECHANICAL	238
Operational Temperature range	238
Environmental Ratings	238
Humidity Range	238
J9, J12 Connector (CNI2e-C only)	238
J7, J11 Connector (CNI2e-C only)	239
TB4 Connector (CNI2e-C only)	239
TB2, TB3 Connector (CNI2e-H only)	240
Serial Port Connector (TxD, RxD, GND)	240
Serial Port Connector (DCD, DSR, DTR)	241
J1 and J2 Power Connectors	241
TB1 Power Input Terminal Block	242
Circuit Board Mounting Holes	242
ELECTRICAL - POWER	243
Input Voltage Range	243
Peak Current Requirements during Transmission	243
Sleep current	243
Boost (Super) Capacitor	243
Low-Voltage Detector	243
Radio Module Power	243
Logic Voltage	243

Approved Battery Pack Assemblies	244
ELECTRICAL - GENERAL	245
Pulse Count (Time-Tagged Interval) Memory	245
Flash Program Memory	245
Static RAM Memory	245
Clocks	245
ELECTRICAL – DIGITAL OUTPUTS	246
Number of outputs	246
Output Configuration	246
Output Configuration (Line-12 on the CNI2-H only)	246
Output Operating Modes	246
Recommended Output Cable	246
ELECTRICAL – DIGITAL INPUTS	247
Number of inputs	247
Input Configuration	247
Input rate (sampling mode)	247
Minimum input pulse width (sampling mode)	247
Sample rate (sampling mode)	247
Debounce Count (sampling mode)	247
Input rate (edge-detection mode)	247
Minimum pulse width (edge-detection mode)	247
Wetting current per input	247
Wetting voltage	247
Input resistance	248
Recommended Input Cable	248
ELECTRICAL – SERIAL PORT	248
Number of input lines	248
Input levels	248
Number of output lines	248
Output levels	248
Bit rate	248
FUNCTIONAL	249
Modes of Operation	249
Cellular Network Communications Options (varies with model and carrier support)	249
Paging Mechanisms	249
Status Indicators	249
Firmware and Configuration Programming	249
CELLULAR RADIO AND ANTENNA INFORMATION	250
CNI2e-H	250
Receive Frequencies	250
Transmit Frequencies	250
Antenna Connector	250
CNI2e-C	250
Receive Frequencies	250
Transmit Frequencies	250
Antenna Connector	250
ASCII CHART	251

Figures

Moisture Prevention Warning	18
CNI2e-H Assembly	19
CNI2e-C Assembly	20
Locations of Captive Screws	21
Example of a Sealing (Cross-Drilled) Screw	22
Recommended Dimensions for a Sealing (Cross-Drilled) Screw	22
Example of a Sealing Technique	23
Locations of Antenna Connectors	24
Antenna Cables for Various Mounting Locations	24
Locations of Antenna Cable for the CNI2e-H	25
Bottom Antenna Cable for the CNI2e-C	26
Side Antenna Cable for the CNI2e-C	26
Typical SIM Card	27
Installation of the SIM Card	27
Locations of Power Inputs	28
Super Capacitor Connection for CNI2e-C	29
Super Capacitor Connection for CNI2e-H	30
Super Capacitor Jumper for CNI2e-H	30
Information Label for the CNI2e-H	31
Information Label for the CNI2e-C	32
CNI2 Enclosure (Door Opened, without battery pack)	33
Wall Mounting Tabs and Dimensions	34
Wall Mount Hangers Assembly Sequence	35
Pipe Mounting using Collar	35
Pipe Mounting using U-Bolts	36
CNI2 with Universal Mounting Bracket (UMB)	37
Bottom View of the Universal Mounting Bracket (UMB)	38
Universal Mounting Bracket (UMB) Hole Pattern	38
Internal View of the Index Base	39
Rotation Gears within the Index Base	39
Index Base with Magnetic Switches	40
Pulse Output Board	41
UMB Magnetic Switch / Pulse Output Wiring	42
Enclosure Sealing Options	43
Lithium Battery Pack Mounting	45
Replaceable Alkaline Battery Pack Mounting	46
Disposable Alkaline Battery Pack	46
Location of the Reserve Capacitor	48
40-5551-1 Lithium Backup Battery Pack	49
Meanwell LPV-20-12 Power Supply	50
40-5589 Power Supply Assembly	50
External Power Supply Connection	51
Typical Solar Power System	52
Solar Altitude	53
Typical Solar Panel Tilt Angles	53
Latitude Map of the United States	54
Combination Square with Protractor Head	54

Solar Panel Tilt Adjustment.....	55
CNI2e-H Circuit Board.....	56
JP3 Configuration Jumpers (CNI2e-H).....	59
Proper Orientation of JP3 Jumpers.....	59
CNI2e-C Circuit Board.....	60
JP3 Configuration Jumpers (CNI2e-C).....	62
JP6 Configuration Jumpers (CNI2e-C).....	63
Proper Orientation of JP3 and JP6 Jumpers.....	63
Serial Port Terminal Block.....	67
Serial and USB Programming Cables.....	68
MP32 [®] Login Screen.....	69
MP32 [®] Device Selection Screen.....	69
Programming Port Configuration Screen.....	70
CNI2 Device Selection Screen.....	71
CNI2e Main Configuration Screen.....	72
Standard Metretek SIP Alarm Descriptions.....	76
Configuration of an Alarm Input.....	77
Configuration of a “Special Purpose” Input.....	79
Configuration of a Pulse Counting Input.....	80
Examples of Using the Scaling Factor.....	81
Changing the Polarity of the “Output-Follows-Input” Feature.....	84
Configuration of a “Special Purpose” Output.....	85
Options Screen.....	86
“Applications” Selection Menu.....	86
Default Port Select Settings.....	89
Serial Port Configuration Screen.....	92
Hardware Flow Control.....	93
CDMA Cellular Configuration Screen.....	101
Destination Modem Baud Rate for CSD Service.....	104
Installation of the SIM Card.....	107
Cellular Settings Screen.....	108
Destination Modem Baud Rate for CSD Service.....	112
Call Scheduling Screen.....	113
Server Mode Enable Checkbox.....	120
Server Mode Screen.....	120
Using a Hardware Input Line to Start and Stop a Server Session.....	122
Server Mode Duration Setting.....	122
Scheduled Server Mode Screen.....	124
Specifying an Alternate Time Server.....	125
Providing the Time from InvisiConnect.....	126
InvisiConnect’s Time Sync feature.....	126
CNI2e Server Time Adjustment.....	128
Early Termination of a Server Session.....	129
Serial Port Listening Port Number.....	131
Attaching the Programming Cable.....	132
PowerSpring OTA Device Selection Screen.....	134
InvisiConnect [®] OTA Configuration Screen.....	136
InvisiConnect [®] OTA Firmware Screen.....	138
Write-protected Item Codes.....	140
Multiple Access Item Codes.....	143
Server Mode (“Call-Out”) Item Codes.....	143

Server Mode Results of Item Code Changes	146
Example Scheduled Server Mode	147
Measurement-Related Item Codes.....	149
Volume Unit Item Codes and Multipliers.....	150
Pulse Value Item Codes and Multipliers.....	151
Energy Unit Item Code and Multiplier.....	152
Raw Pulse Count Item Code Settings	153
Correction and Conversion Equations.....	154
Selecting the Audit Trail Size in MP32	155
“First-Time” Item Code Default Values	158
Reset Item Code Default Values	159
Reset Item Code Default Values (continued)	160
Serial Connection to the CNI2e.....	161
Enabling Transparent Modem Operation.....	162
Power Preservation Mode Jumper on CNI2e-C.....	165
Power Preservation Mode Jumper on CNI2e-H.....	166
Low-Battery Alarm Point	167
Hardware Trigger Example #1	169
Hardware Trigger Example #2	169
Hardware-Triggered “Power Preservation Mode” Settings for Metrotek Devices	170
Hardware-Triggered “Power Preservation Mode” Settings for Mercury Devices	171
Example of Error Code “35” Display.....	173
LED Error Codes 11 thru 19.....	174
LED Error Codes 21 thru 29.....	175
LED Error Codes 31 thru 39.....	176
LED Error Codes 41 thru 45.....	177
LED Error Codes 46 thru 49.....	178
LED Error Codes 51 thru 59.....	179
LED Error Codes 61 thru 83.....	180
Example of Timed Sampling	182
Example of Switch Bounce	182
Example of Debouncing Process	183
Typical Form-A and Form-C (KYZ) Connections on a CNI2e-C	184
Example of Detection of a Form-C Fault	184
Polarities of the Output Lines (CNI2e-C shown)	185
Accuracy Errors Using the “Output-Follows-Input” Feature	186
Delay Errors Using “Output-Follows-Input” Feature.....	186
Converting the CNI2e’s Logic Output to Dry Contact.....	187
Changing the Polarity of the “Output-Follows-Input” Feature.....	188
Converting the CNI2e-C’s “J9” or “J12” Output to Dry Contact.....	189
Converting the CNI2e-C’s “J11” Output to Dry Contact	189
CNI2e-H Line-12 Configuration Jumpers.....	190
Typical CNI2e “AT” Responses.....	191
Starting the PowerSpring System Configuration.....	196
Changing the Data Collection Configuration.....	197
Configuring the SIP Server	198
Configuring PowerSpring for CSD Connections	199
Configuring a Call Schedule.....	200
Defining a Call Profile Name	201
Defining a Call Profile.....	202
Starting the CNI2e Configuration Process.....	203

Remote Unit Selection Screen	204
Device Type Selection Screen	204
Add Remote Unit Screen	205
Remote Unit Configuration General Information Screen.....	206
Device Configuration Screen.....	207
Data Input Configuration Screen	208
Call Information Screen.....	209
Hardware Alarm Configuration Screen.....	210
Viewing the Cellular and Hardware Status	215
Cellular and Hardware Status Screen	216
Starting the Call Diagnostic Dump Utility	217
Using the Call Diagnostic Dump Utility	218
Status and Cellular Information on the Call Dump Screen.....	218
Cellular Information Fields	219
Hardware Alarm-Sensing Troubleshooting Guide	220
Pulse-Counting Troubleshooting Guide.....	221
Power Source Troubleshooting Guide.....	222
Network Low-Signal Troubleshooting Guide	223
Network Connection (Client Mode) Troubleshooting Guide	224
Network Connection (Server Mode) Troubleshooting Guide.....	225
Network Connection (Server Mode) Troubleshooting Guide (continued).....	226
Serial Port Troubleshooting Guide	227
Serial Port Troubleshooting Guide (continued).....	228
CSA Safety Label.....	229
J9 and J12 Connectors on the CNI2e-C.....	238
J7 and J11 Connectors on the CNI2e-C.....	239
TB4 Plug on CNI2e-C	239
TB2 and TB3 Plug on CNI2e-H	240
Serial Port Plug (short).....	240
Serial Port Plug (long).....	241
TB1 Power Terminal Block.....	242
PCA Mounting Hole Locations	242
CNI2e-H Line-12 Configuration Jumpers.....	246
CNI2e-H Line-12 Input Configuration Jumpers.....	247
ASCII Conversion Chart.....	251

REVISION HISTORY

Version 1.0 August 26, 2013

- Initial release.

Version 1.1 November 7, 2013

- Corrected the FCC ID numbers for the Telit c24 (CDMA) radio.

Version 1.2 January 23, 2014

- Added a new section detailing the CNI2e mounted in an outdoor enclosure, including assembly photos.
- Added notes about operation on the Aeris network.
- Removed any reference to Sprint.
- Corrected several Transmit/Receive frequencies in the Specifications section.
- Added more explanation to some of the LED error codes.

Version 1.3 July, 2016

- Added CSA Control / Installation Drawings.
- Corrected the instructions for changing the gear rotation on the UMB index.
- Added information about Measure Canada certification.
- Removed any references to Regal + Messtechnik GmbH (RMG).
- Replaced references to the "DC-2009" data collection software with "PowerSpring".
- Added illustrations of the proper jumper orientation for the JP3 and JP6 jumper blocks.
- Removed any references to a device called the "Dual Port Multiplexer", which is no longer offered as an option.
- Changed several of the NIST Timer Server IP addresses.

TRADEMARKS AND COPYRIGHTS

“Windows” refers to Microsoft Windows 2000, XP, Vista and Windows-7, 8 or 10 that are either registered trademarks or trademarks of Microsoft Corporation in the United States and/or other countries.

“MV90®” is either a registered trademark or trademark of the Itron Corporation.

“PowerSpring®” “DC-2009®” “MP32®”, “InvisiConnect®” and “Masterlink®” are either registered trademarks or trademarks of Honeywell International.

“AutoSol®” is either a registered trademark or trademark of Automation Solutions and refers to their AutoSol Enterprise Server (AES).

Other brands and product names are trademarks or registered trademarks of their respective holders.

HISTORICAL REFERENCES

Metrotek, Inc. was a US business that produced data logging and telemetry products, and enterprise software, between 1977 and 2008.

Metrotek was acquired by **Mercury Instruments, LLC**, another US business, in 2008 and the **Metrotek** name was retired.

The **Metrotek** and **Mercury** names appear in this document as references to legacy products and protocols, which are still in use today.

“PowerSpring®” is an enterprise-class data collection system, formerly known as **“DC-2000®”** and **“DC-2009®”**.

Honeywell | Mercury Instruments
512 Virginia Drive. Ft. Washington, PA 19034 USA
Phone 302-669-4253 • Toll Free 855-251-7065

www.Honeywellprocess.com

SYMBOLS

The following symbols may be found within the text of this document, or may be marked directly on the equipment.



Caution or Danger



Shock Hazard



Earth Ground Connection

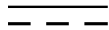

Direct Current

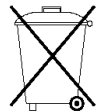

Hazardous Waste Disposal



Denotes an information item



Denotes a user action item



Denotes an example line

Caution or Danger: Alerts the operator to special precautionary actions that may be required, or danger hazards that exist or have the potential to exist.

Shock Hazard: Alerts the operator to an electrical shock hazard condition that exists or could potentially exist.

Earth Terminal: Symbol that indicates earth ground. A copper rod buried in the ground is a common example of an earth ground connection, although these can take various forms. Reference your local electrical code regulations for detailed information.

Direct Current: Internationally recognized symbol that represents voltage in the form of direct current. A common example of a direct current (DC) source is an automotive car battery.

Hazardous Waste Disposal: Alerts the operator that the equipment or component thus labeled is not to be disposed of without special consideration to the hazardous waste that it contains. Compliance is necessary to ensure that national, state, and local community legal statutes are not violated.

FCC Warning:

This device complies with Part 15 of the FCC Rules. Operation is subject to the following two conditions: (1) This device may not cause harmful interference, and (2) this device must accept any interference received, including interference that may cause undesired operation.



Warning

The CNI2e-H contains a radio-frequency transmitter,
Gemalto/Cinterion Model PHS8-P GSM/HSPA Module,
FCC ID # QIPPHS8-P
IC ID # 7830A-PHS8P

The combined cable loss and antenna gain must not exceed +6.8 dBi (850 band), +1.9 dBi (900 band), +7.7 dBi (1800 band) or +2.2 dBi (1900 band). Total system output must not exceed 2.0W EIRP in the 1900 band in order to comply with the EIRP limit of 24.232.

The product must be installed in a manner that provides a minimum separation distance of 20cm (8") or more between the antenna and users and persons and must not be co-located or operate in conjunction with any other antenna or transmitter to satisfy exposure requirements.



Warning

The CNI2e-C contains a radio-frequency transmitter,
Motorola Model c24, FCC ID # IHDP56JE1 or
Telit Model c24, FCC ID # RI7P56JE1

The combined cable loss and antenna gain must not exceed +5.3dBi (800 band). The combined cable loss and antenna gain must not exceed +4.2dBi and total system output must not exceed 2.0W EIRP in the PCS (1900) band in order to comply with the EIRP limit of 24.232(b).

The product must be installed in a manner that provides a minimum separation distance of 20cm (8") or more between the antenna and users and persons and must not be co-located or operate in conjunction with any other antenna or transmitter to satisfy exposure requirements.

IMPORTANT BATTERY INFORMATION



Caution

Disposal of lithium battery cells is strictly regulated in most areas as hazardous waste material. Consult your regional waste disposal authority to ensure full compliance with legal statutes when disposing of cells.



Warning

Transport of primary cell lithium batteries (even when fully discharged) of this type is strictly forbidden on passenger aircraft. Cargo shipment of batteries via UPS, FedEx, etc., requires special shipping containers, packing, and paperwork to be completed.

Domestic Requirements

Class-9 is a general class designation by the DOT and has specific packaging instructions. Lithium primary cells are 'Class-9' if they contain more than 5.0 grams of lithium. This is applicable to the lithium battery packs intended for use with the CNI2e-H or CNI2e-C.

Specific requirements are applicable to Class-9 shippers:

Product handlers must be tested and certified. Packaging must meet Group II requirements and boxes must be tested by UN specification. Packaging must be clearly marked to indicate:

- Lithium batteries, UN3090, PG II,
- Number of packages,
- Emergency phone number,
- Shipper certification.
- MSDS information must also be included within the package.

Additional requirements may apply, or come into force in the future. Please confirm all requirements in advance with your shipper.

OVERVIEW

The Honeywell CNI2e-H and CNI2e-C are pulse accumulators (data loggers) and wireless data communications modems with integral cellular radio transceivers. Dry contact pulse and/or alarm signal inputs can be supplied from an external device such as an electronic gas volume corrector, an electric meter or other device.

Asynchronous serial data communications with an external instrument is also possible. Both RS-232 and CMOS-level UART signals are supported.

The CNI2e can be powered by a dc power source in the range of 4 – 28 Vdc. Peak current can be quite high during transmission, with peaks reaching 1.8A for short durations. The use of alkaline or lithium battery packs usually require the use of a super-capacitor to assist during peak current moments.

FEATURES

- Wide power supply range of 4 – 28 Vdc.
- Up to six dry-contact pulse counting and/or alarm inputs.
- Up to six digital outputs (3.3V). For the CNI2e-H one of these outputs can be configured as a dry-contact (open-collector) output that can be pulled as high as 28Vdc.
- The CNI2e-H supports 2G (GSM/GPRS) and 3G (UMTS/HSPA) cellular radio service.
- The CNI2e-C supports 2G (CDMA/1X) cellular radio service.
- Power Preservation Mode extends battery life during the loss of primary power.
- Over-the-air firmware update capability allows for new feature enhancements as they become available (except in Canada when being used as a billing device).
- Over-the-air configuration update capability allows for changes in the operating environment once the device is put into service (except in Canada when being used as a billing device).

CNI2E-H CERTIFICATIONS

- PTCRB cellular network approvals.
- Industry Canada & FCC Part 15(b), 22, 24.
- Approved for use on AT&T, T-Mobile, Rogers, Telus and Bell Mobility UMTS (3G) and GSM (2G) networks.
- CSA Class-1/Div-2 safety certification.
- Measurement Canada metrology approval (AG-0618)

CNI2E-C CERTIFICATIONS

- Intertek / Verizon Open Development Initiative (ODI) Specification Version 4.0 cellular network approvals
- Industry Canada & FCC Part 15(b), 22, 24
- Approved for use on Verizon and Aeris CDMA/1X networks
- CSA Class-1/Div-2 safety certification.

SLEEVE ASSEMBLY

NOTE

The CNI2e assemblies are not weather-resistant.
They must be mounted inside another enclosure suitable for outdoor use.

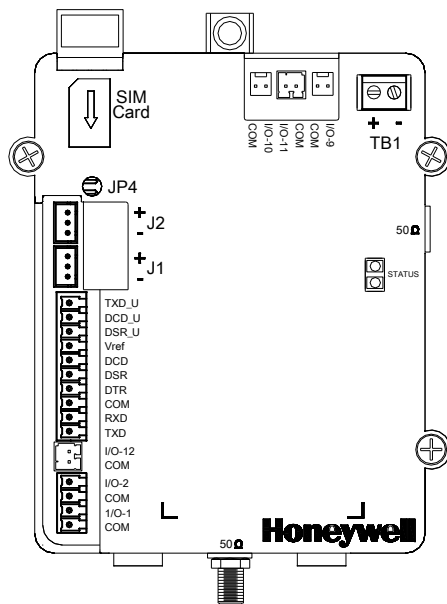

Moisture Prevention Warning

CNI2e-H Assembly

The CNI2e-H has six digital I/O lines that can be individually configured as alarm inputs, pulse-counting inputs or control/repeater outputs. The CNI2e-H also has a serial communications port. All lines are accessible using pluggable terminal blocks. A 3/32" (2.4 mm) slotted screwdriver is required for the screws in the removable portions of the blocks.

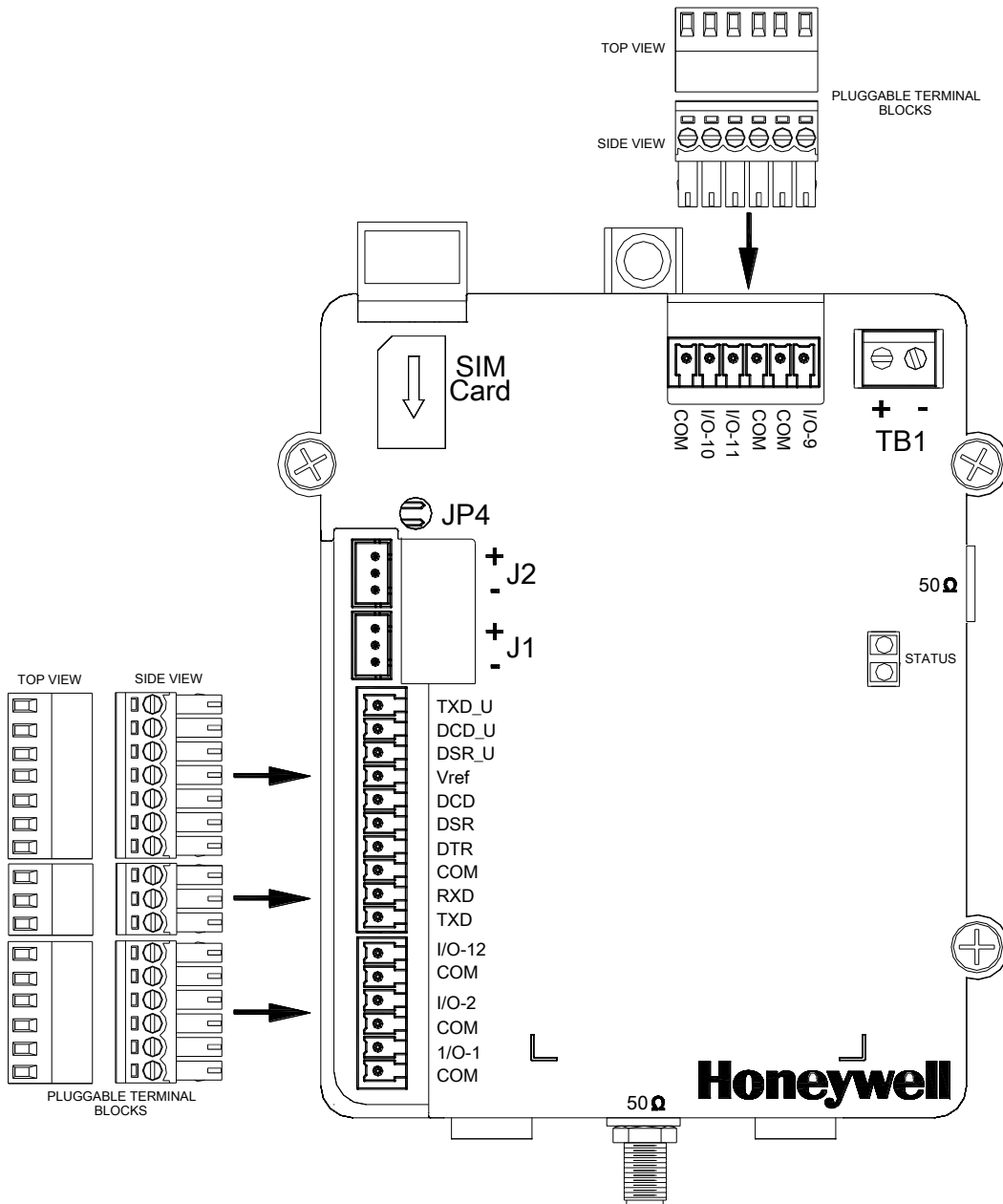

CNI2e-H Assembly

CNI2e-C Assembly

The CNI2e-C has six digital I/O lines that can be individually configured as alarm inputs, pulse-counting inputs or control/repeater outputs. The CNI2e-C also has a serial communications port.

Two of the lines are accessible using pluggable terminal blocks. A 3/32" (2.4 mm) slotted screwdriver is required for the screws in the removable portions of the blocks.

Another two lines employ pluggable terminal blocks that do not require a screwdriver. These contain a push and lock mechanisms.

The remaining two lines require MTA-100 style connectors. These are usually reserved for the connection of CALL and TAMPER magnetic switches. However they can also be used as additional pulse/alarm inputs or control outputs.

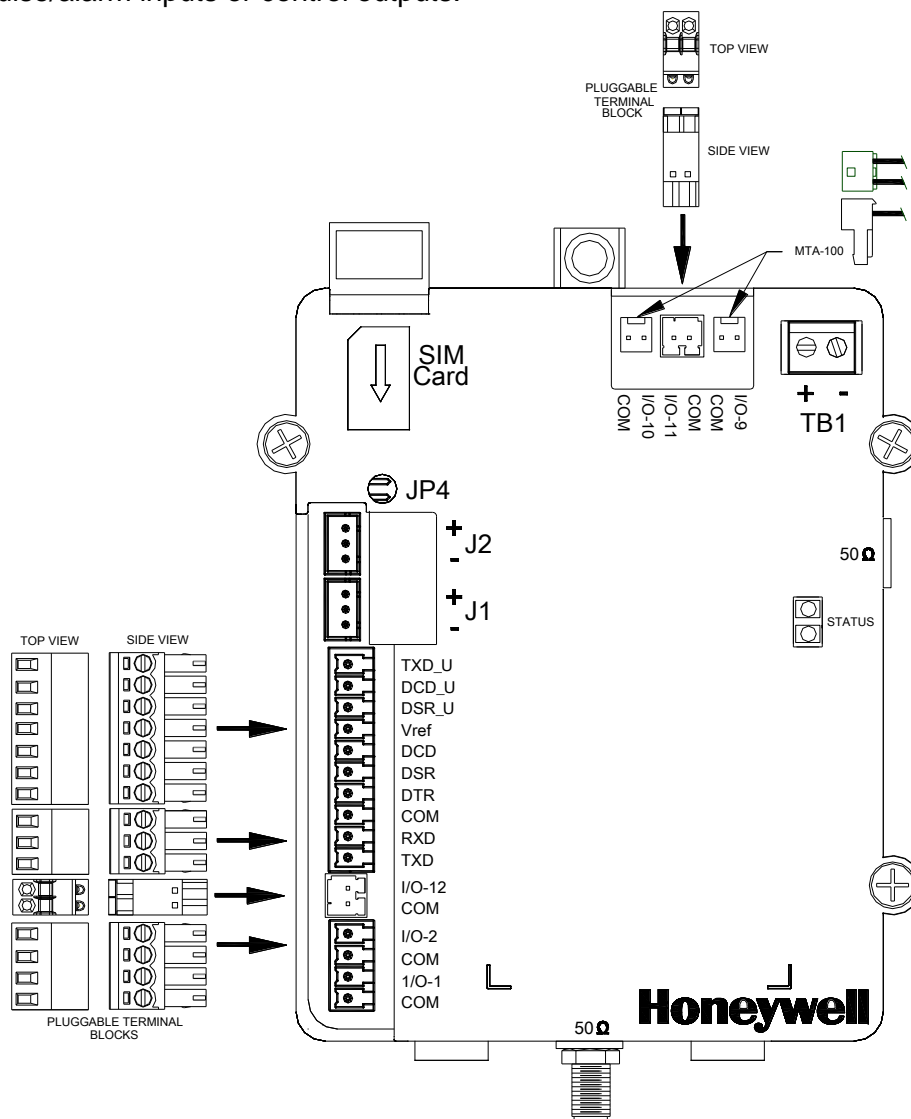

CNI2e-C Assembly

Location of the Cover Fasteners

It is not necessary to completely remove the three Phillips screws from the cover. Once they release from the base they will remain captive with the cover. Generally the only time you will need to remove the cover is to access the programming port to configure the unit for first-time use.

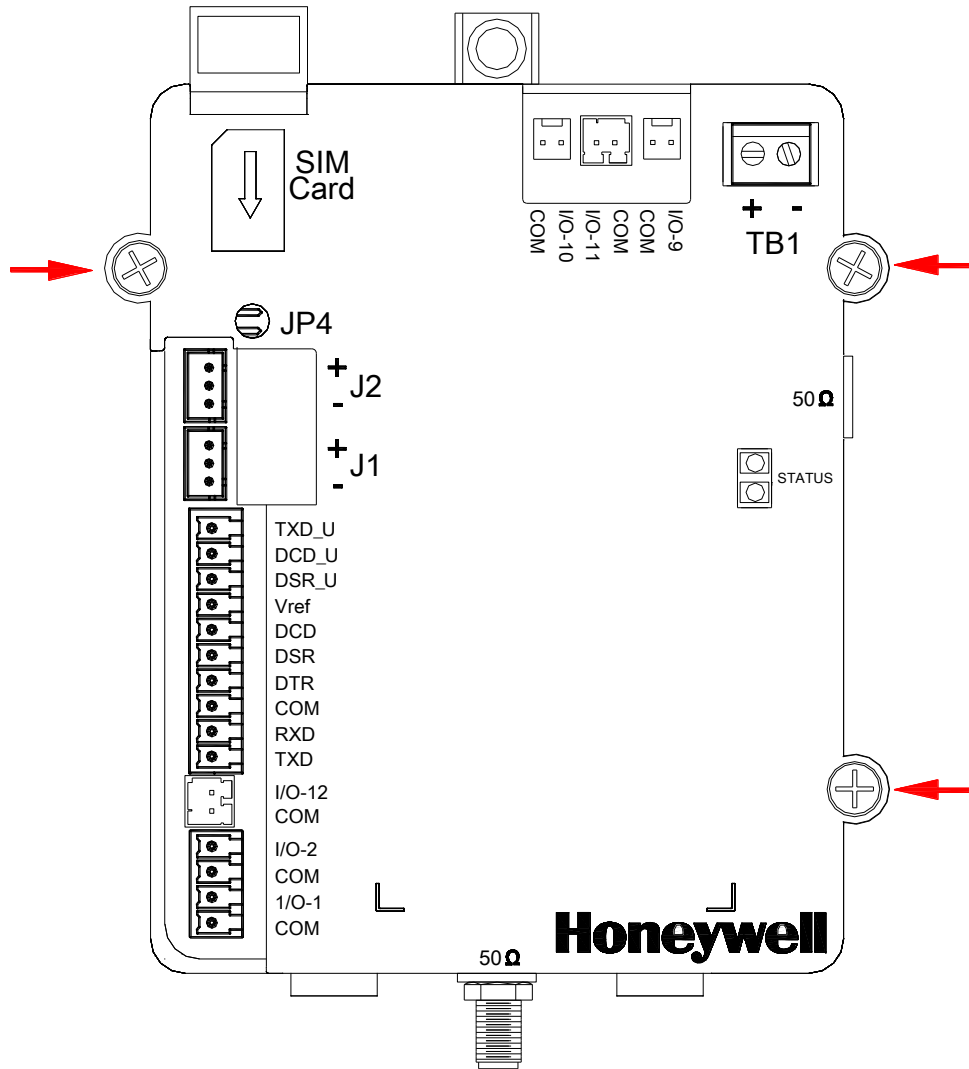

Locations of Captive Screws

Metrological Sealing

If it is necessary to install a metrological sealing device such as a wire tag, two of the cover screws can be replaced with a cross-drilled screw such as the one shown here.



Example of a Sealing (Cross-Drilled) Screw

The threads must be 6-32 and the overall length of the screw shaft (not including the head) should not exceed $\frac{1}{2}$ " (12.7 mm). The threaded portion should be $\frac{1}{4}$ " (6.35 mm) and the undercut (captive) portion $\frac{1}{4}$ " (6.35 mm).

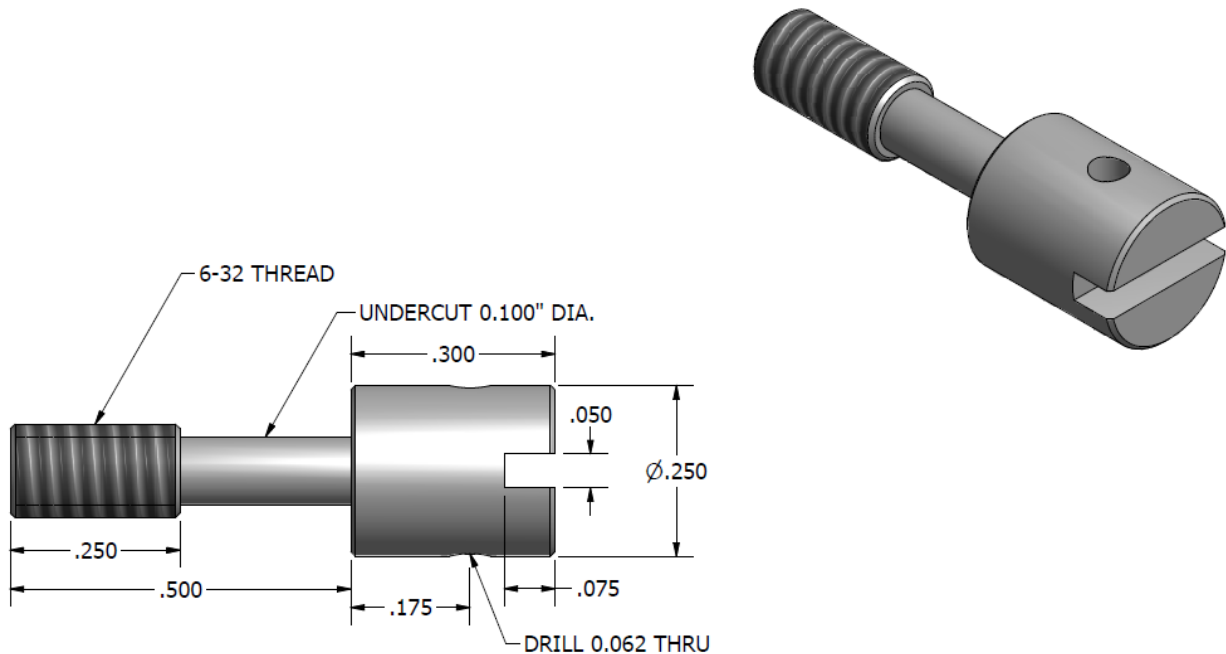

Recommended Dimensions for a Sealing (Cross-Drilled) Screw

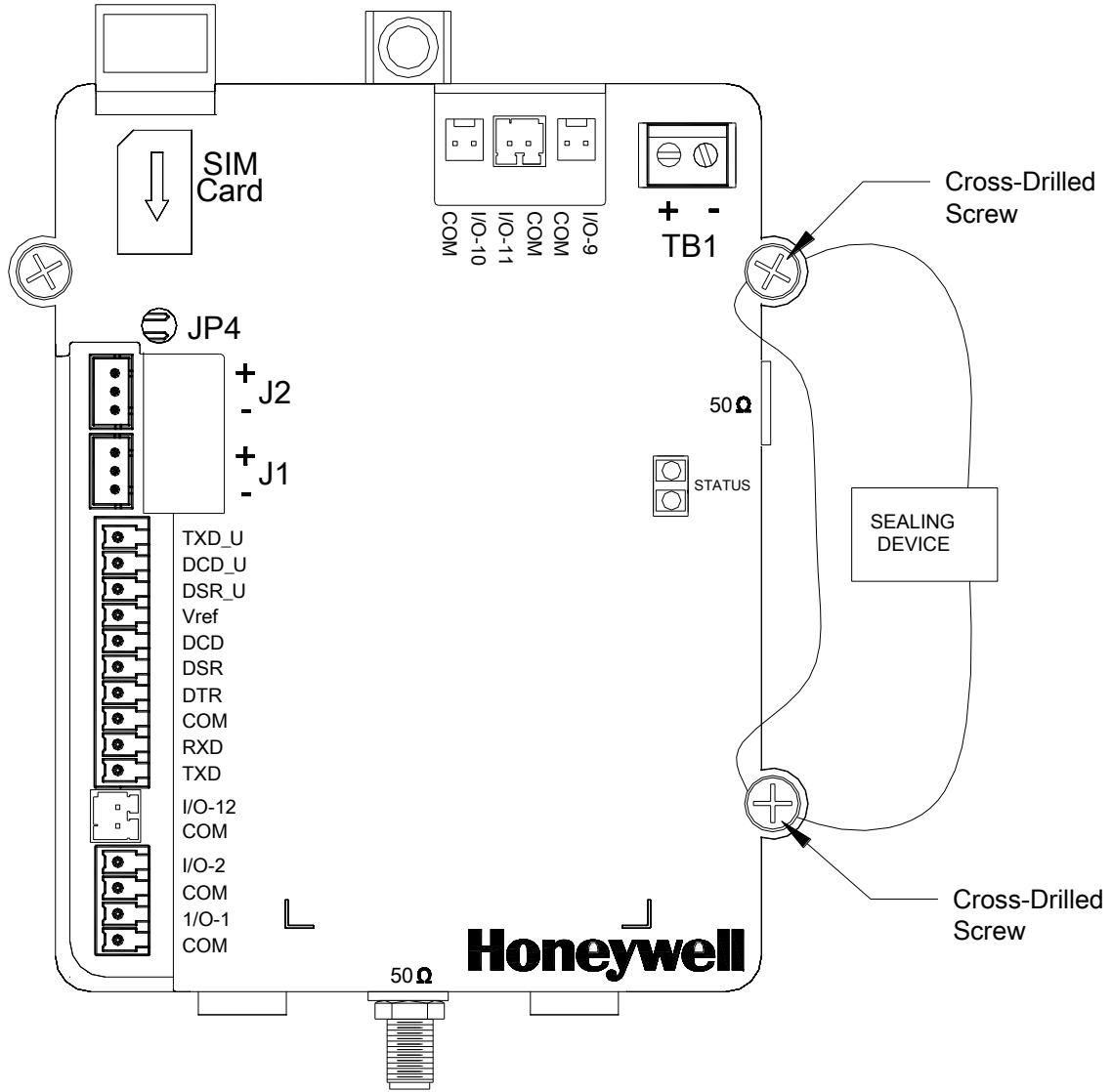

Example of a Sealing Technique

Location of Antenna Connectors

There are two possible locations for the SMA female antenna connector.

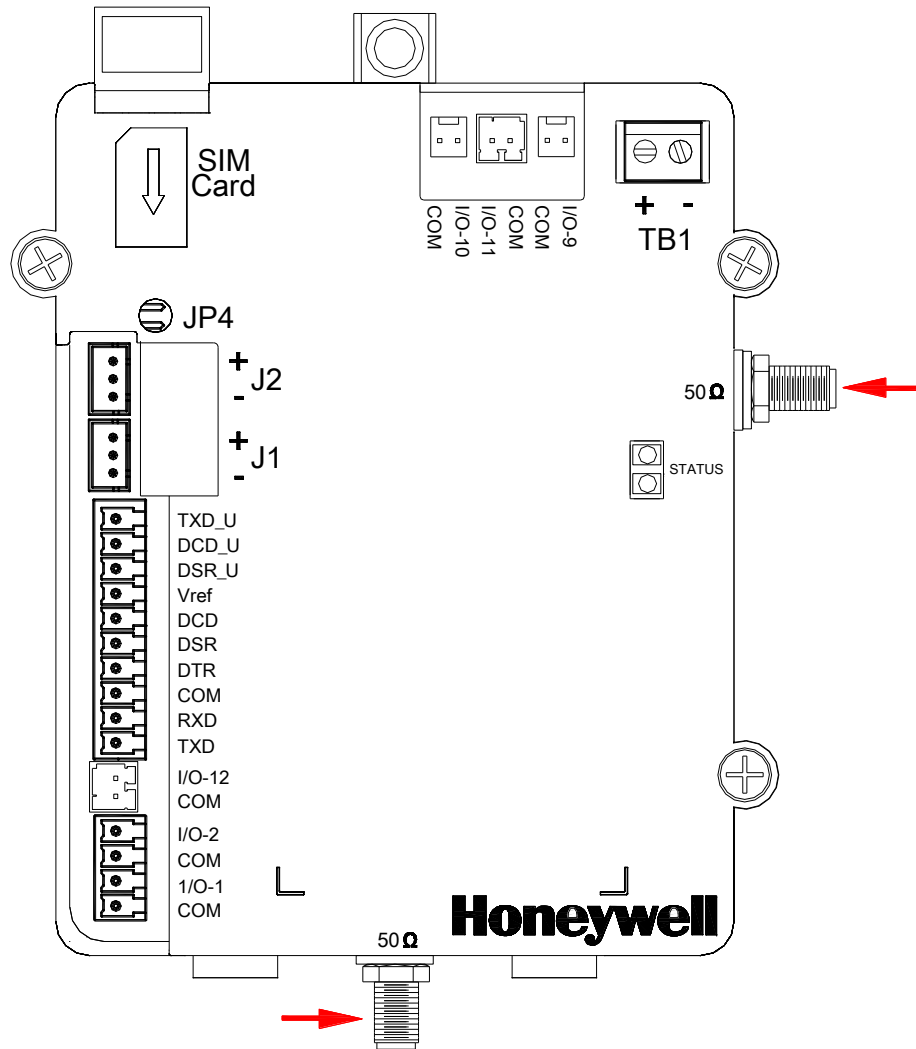

Locations of Antenna Connectors

Changing the antenna connector from one location to another may require the use of a different antenna cable within the enclosure. See the next illustrations.

DEVICE	ANTENNA CABLE FOR BOTTOM MOUNT	ANTENNA CABLE FOR SIDE MOUNT
CNI2e-H	40-5278	40-5278
CNI2e-C	40-5278-2	40-5278-1

Antenna Cables for Various Mounting Locations

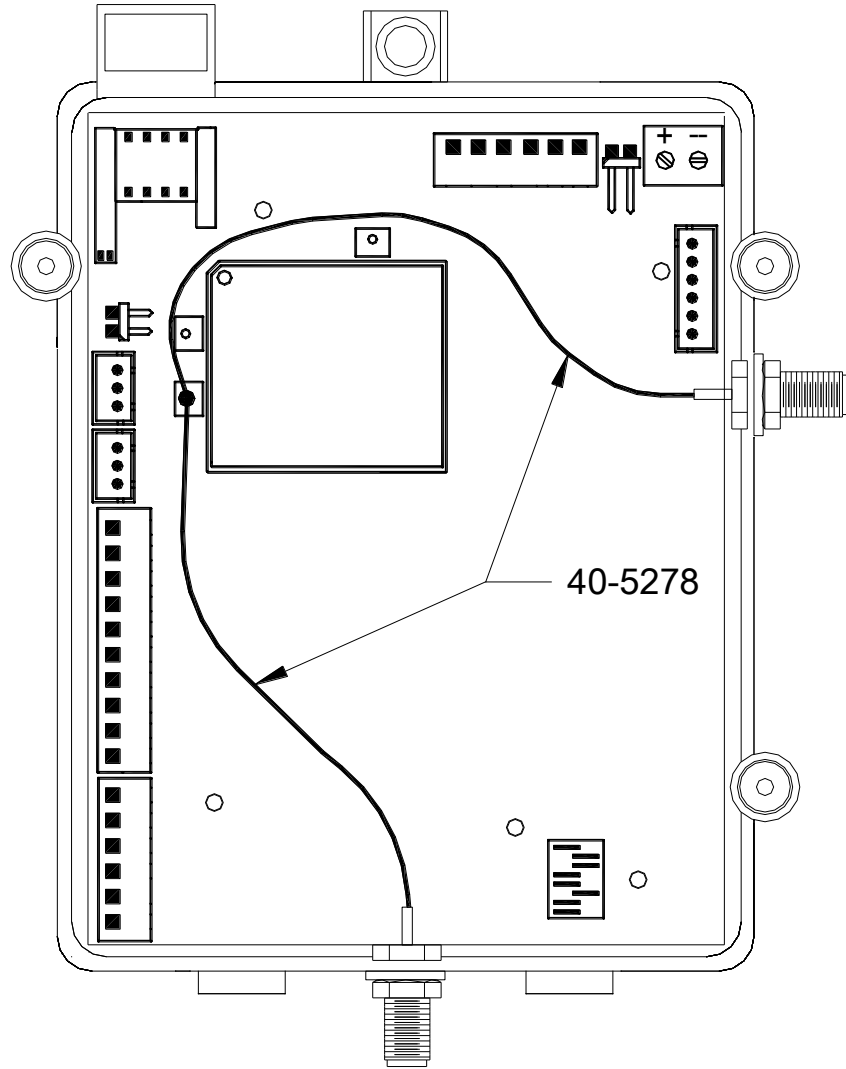

Locations of Antenna Cable for the CNI2e-H

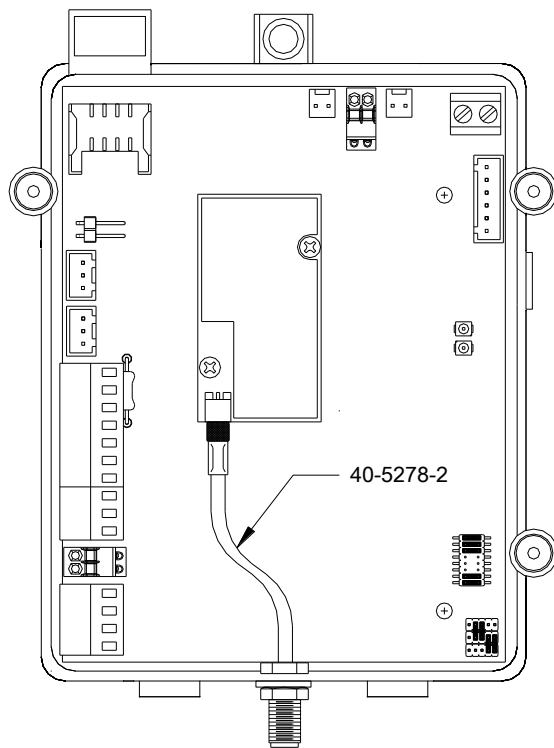

Bottom Antenna Cable for the CNI2e-C

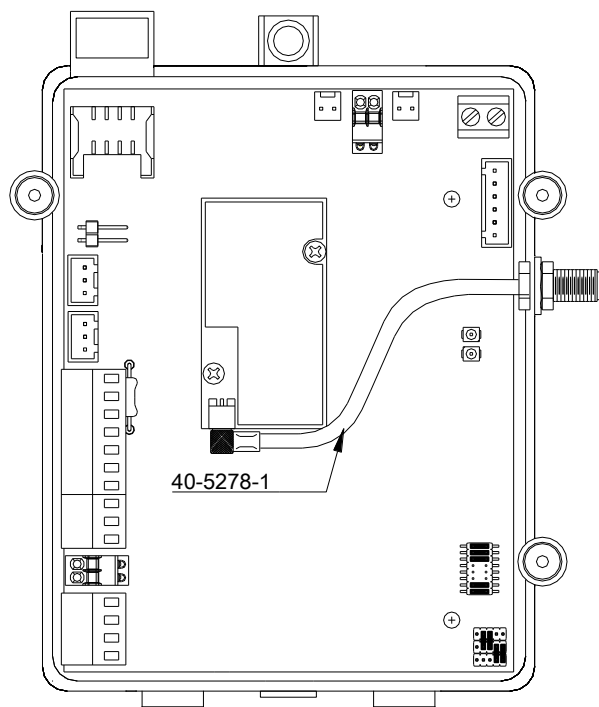

Side Antenna Cable for the CNI2e-C

Installation of the SIM Card.

Only the CNI2e-H requires a SIM card.

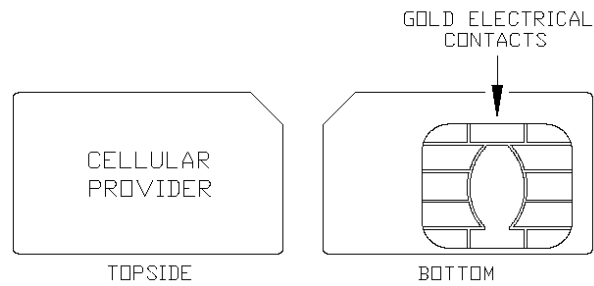
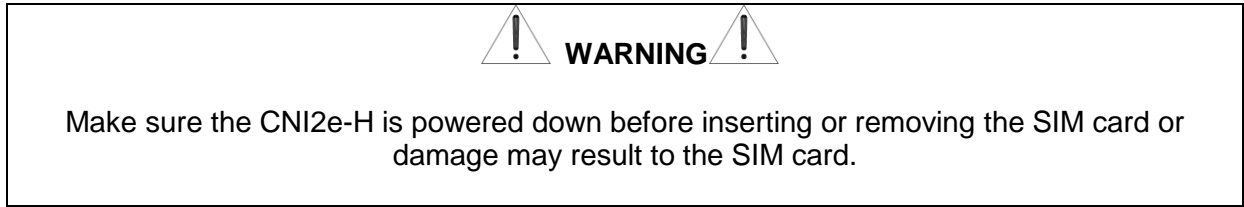

Typical SIM Card

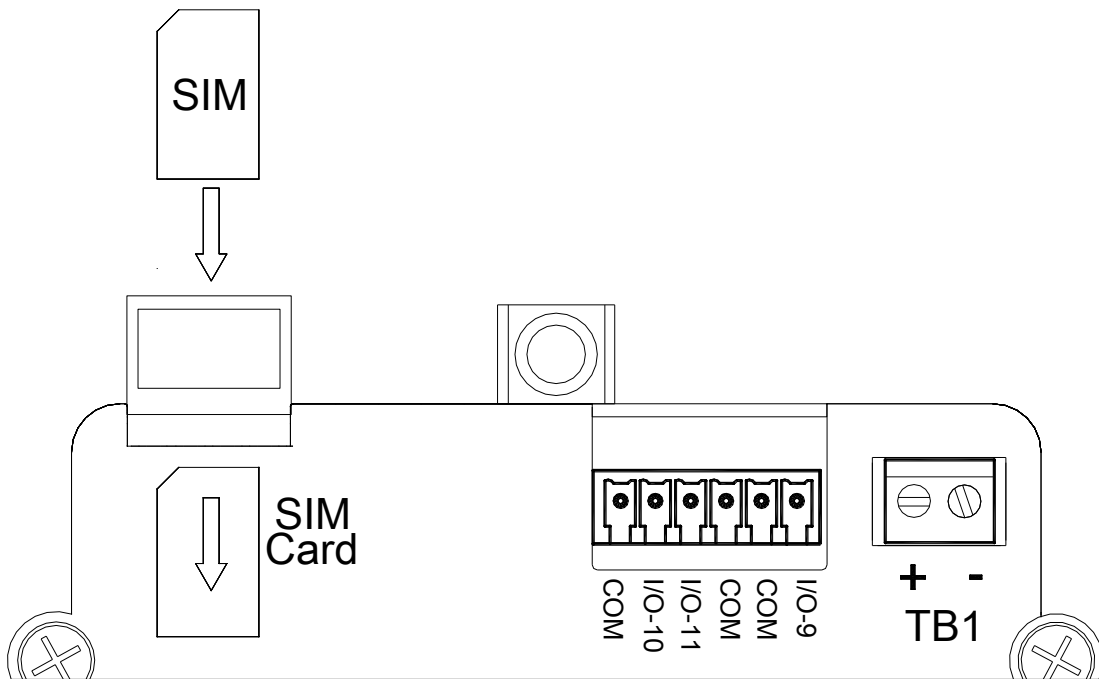

Installation of the SIM Card

Location of Power Inputs

If more than one power source is connected at the same time, the one with the highest voltage will supply a majority of the current.



WARNING

Do not connect a super-capacitor to the TB1 terminal block until you have read the next few pages. Failure to understand this could lead to damage to the super-capacitor or the circuit board.

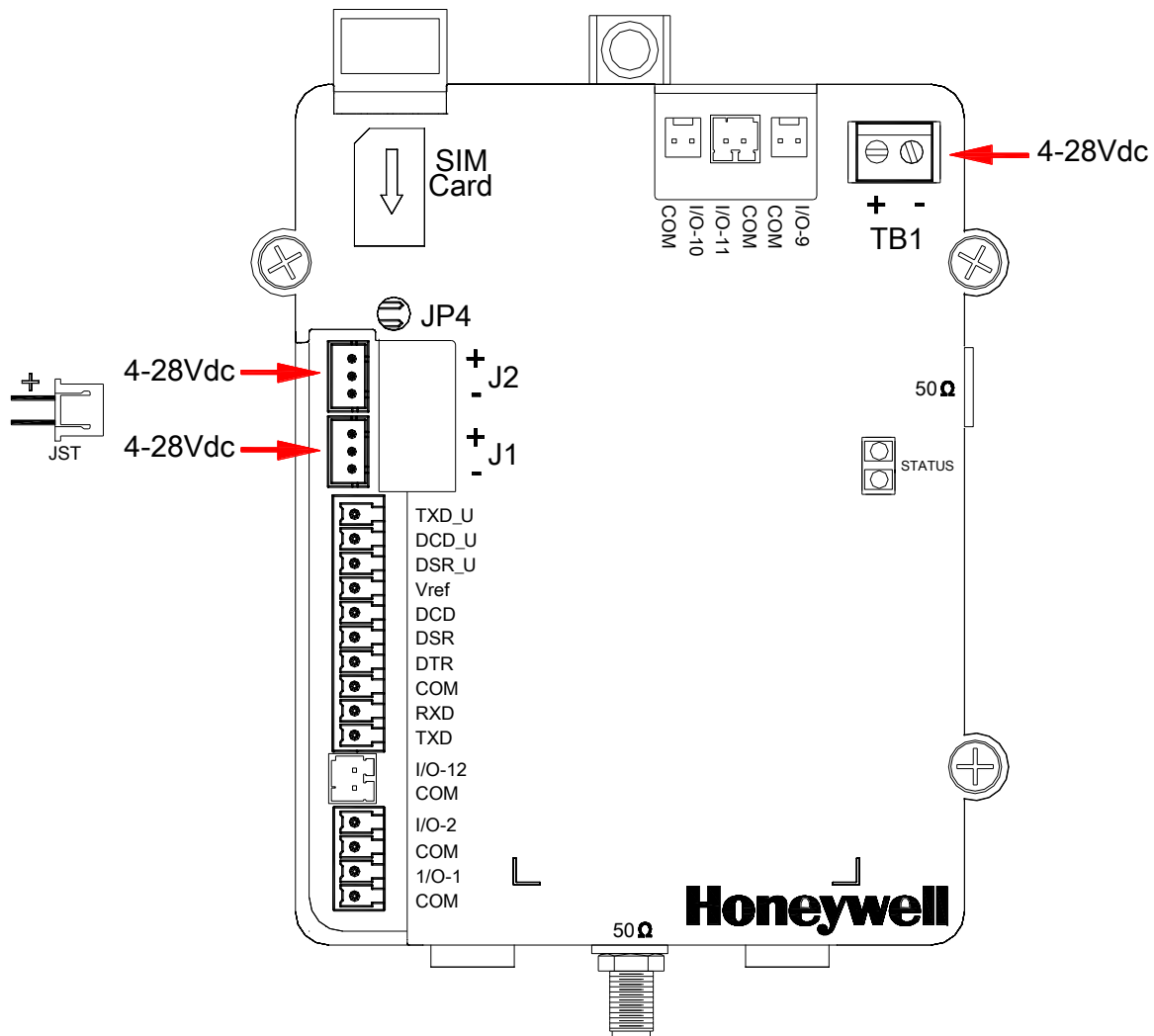

Locations of Power Inputs

Use of a Super Capacitor



WARNING

When using a super-capacitor, the voltage on J1 or J2 must **never** exceed 7.5V dc.

Depending on the proximity to the cellular tower and local interference, GSM / UMTS radios can require up to 1.8 amps for short durations during transmission. CDMA radios can require up to 750 mA continuous under extreme conditions. This magnitude of current is difficult for alkaline and most lithium batteries to produce. This can cause the battery voltage to sag to a point that causes the CNI2e to reset, or cause the radio to cease transmissions. It can also shorten the life of the batteries.

A super-capacitor can be used to assist alkaline and lithium batteries. When the CNI2e's radio is powered down the capacitor is charged up by the batteries. During transmission the capacitor provides the additional current that the batteries can't supply.

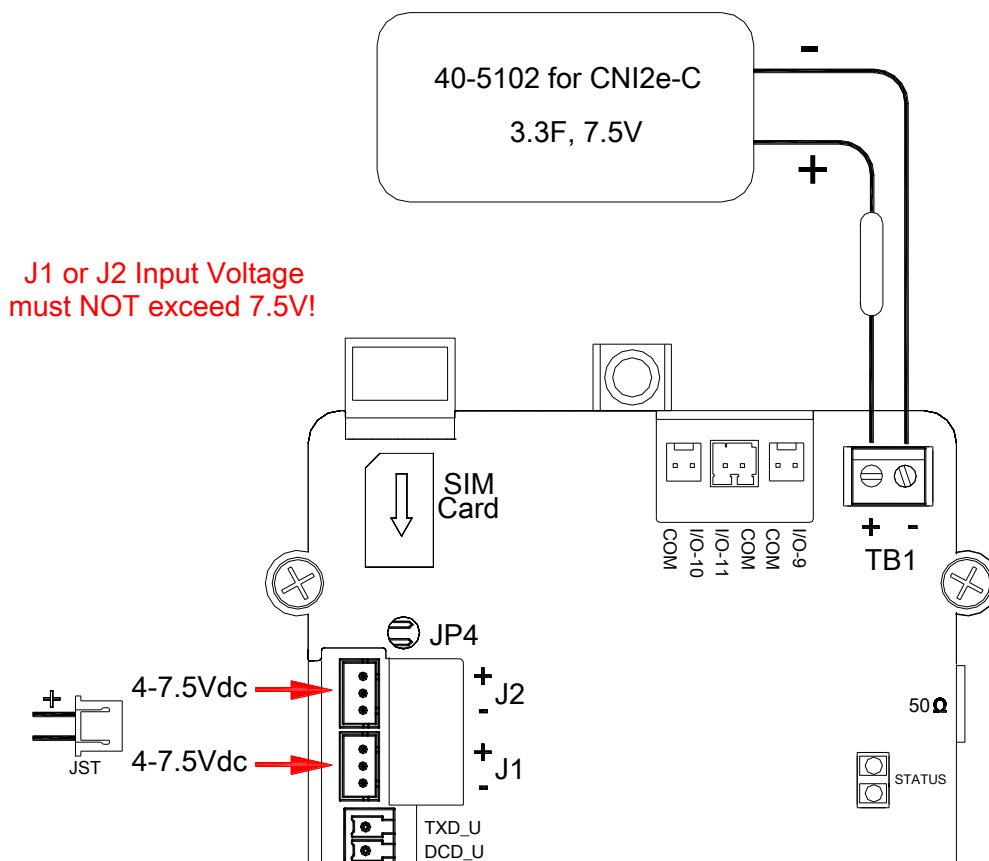

Super Capacitor Connection for CNI2e-C

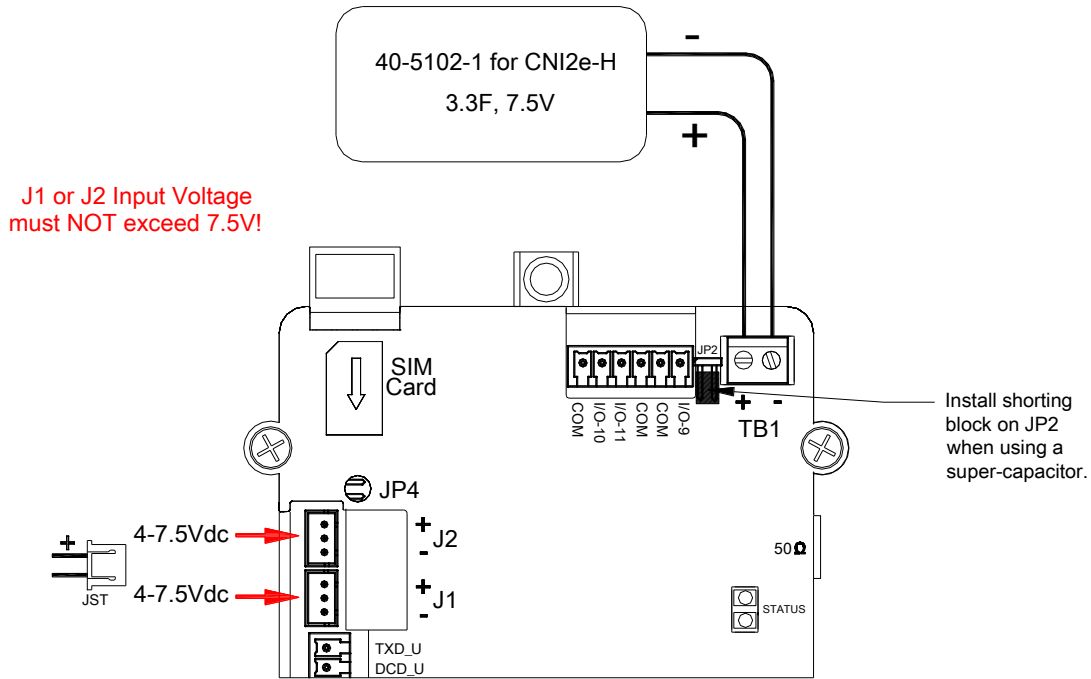

Super Capacitor Connection for CNI2e-H

To use a super-capacitor on the CNI2e-H, a shorting block must be installed on a jumper called “JP2” located next to the TB1 terminal block. This is only accessible by removing the top cover.

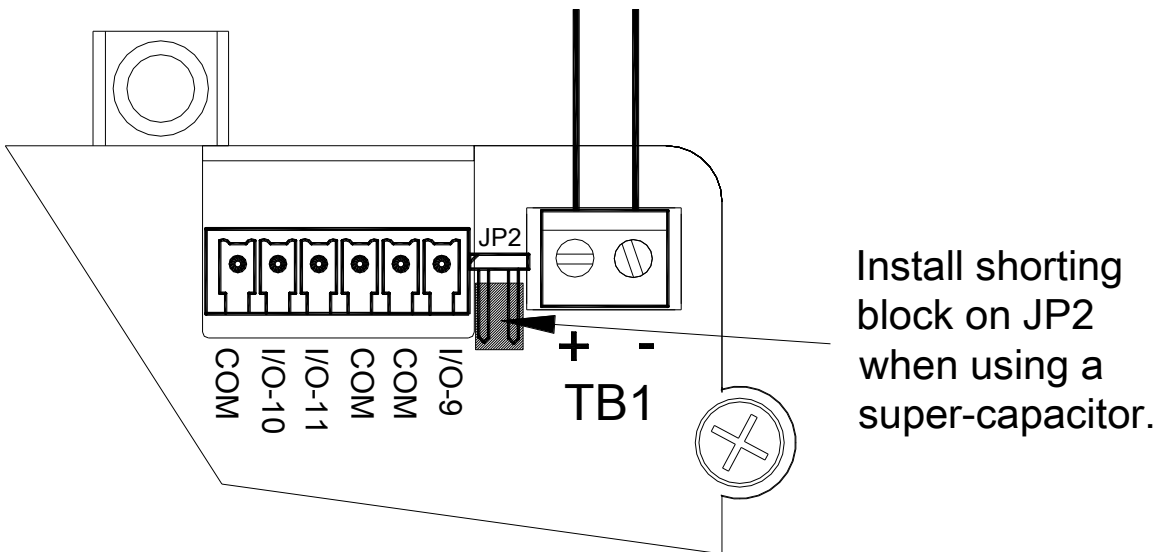

Super Capacitor Jumper for CNI2e-H

CNI2e-H Label

You may need the radio's International Mobile Equipment Identity (IMEI) Number when ordering cellular service. This appears as both a numeric value as well as a barcode on the label.

CNI2e-H

This product contains a radio-frequency transceiver
Cinterion/Gemalto Model PHS8-P
FCC ID # QIPPHS8
Contains IC: 7830A-PHS8P
FICRB Cert #38497

	Receive (MHz)	Transmit (MHz)
(5) GSM, WCDMA	869-894	824-849
(8) GSM, WCDMA	925-960	880-915
(3) GSM, WCDMA	1805-1880	1710-1785
(2) GSM, WCDMA	1930-1990	1850-1910
(1) WCDMA	2110-2170	1920-1980

Power Requirements: 4-28Vdc, 1.5A
Antenna Requirements: Impedance: 50Ω

Antenna gain including cable loss must not exceed
+5.3 db(850 MHz) and +4.2 db(1900MHz)

Honeywell | Mercury Instruments
1280 Kemper Meadow Dr. Cincinnati, OH 45240 USA
Phone: 513-272-1111 www.honeywell.com

IMEI = 359998044461699

S/N: BP15W10-A6335

See User's Guide for complete details.

Information Label for the CNI2e-H

CNI2e-C Label

You will need the radio's Mobile Equipment Identifier (MEID) Number when ordering cellular service. This appears as both a numeric value as well as a barcode on the label. Since CDMA technology does not use SIM cards, each radio within the CNI2e-C is provisioned for one specific carrier. The carrier name is located on the label above the MEID number (green arrow in the image below). This will be either Verizon or Aeris.

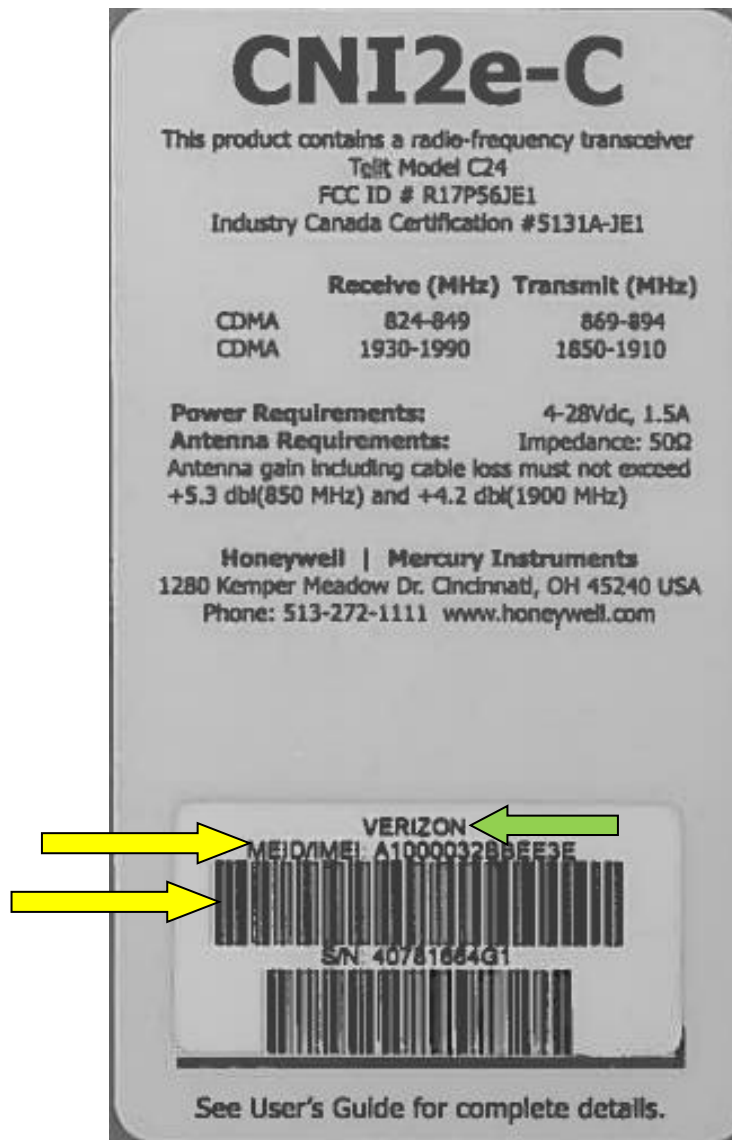

Information Label for the CNI2e-C

OUTDOOR ENCLOSURE

The CNI2e is available in a ruggedized weatherproof enclosure containing a tamper-proof antenna and battery pack. This assembly is simply called the “CNI2”. Cable inlets are provided to connect to external equipment for pulse-counting, alarm-sensing and serial communications.

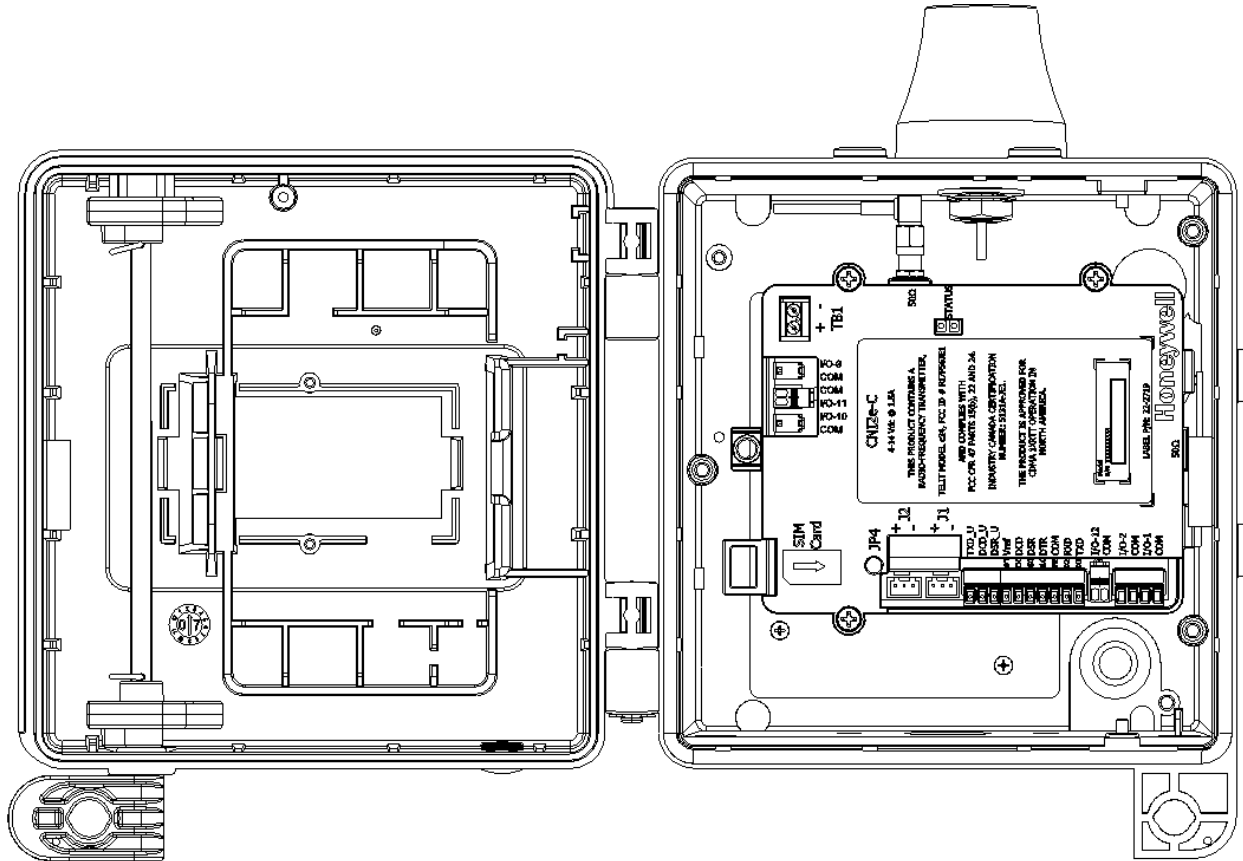

CNI2 Enclosure (Door Opened, without battery pack)

INSTRUMENT MOUNTING OPTIONS

A number of options are available for convenient installation of the CNI2. These should be clearly specified at the time of order to ensure that the field technician has everything he or she needs to install the product.

Wall Mounting

Where a flat wall surface is available, such as on the side of a building or shed, stainless steel “hangers” can be utilized. Illustrated below is the rear view of a CNI2, along with associated mounting dimensions.

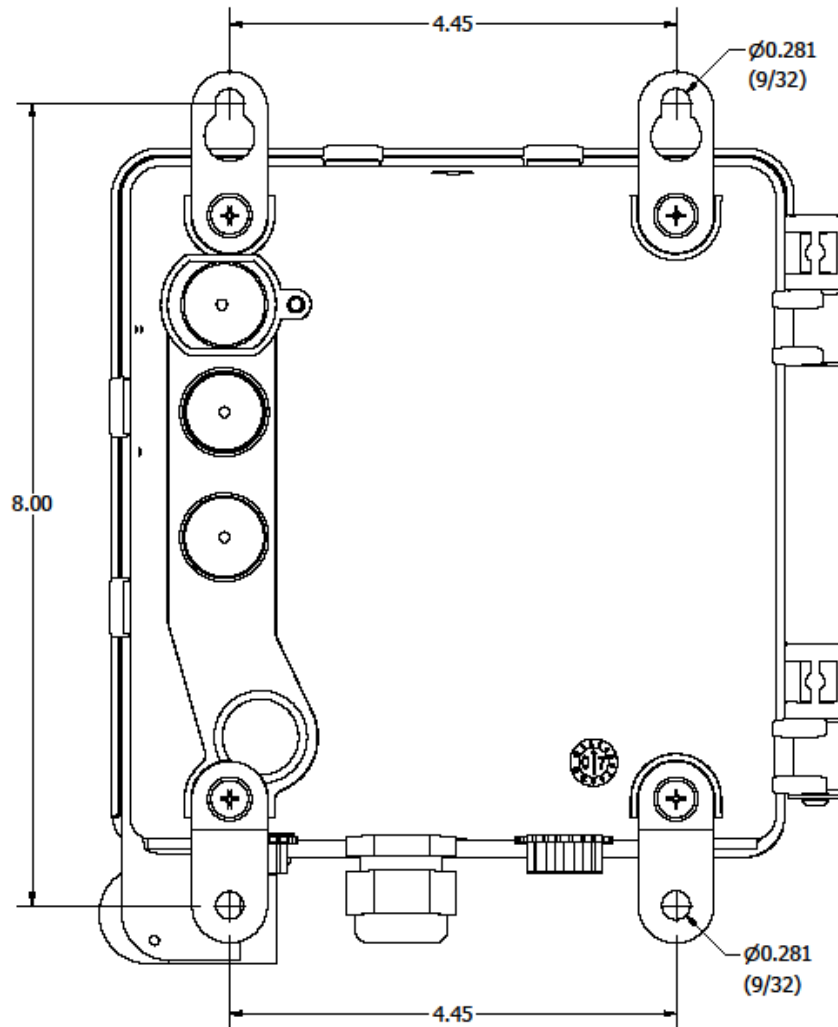

Wall Mounting Tabs and Dimensions

Assembly sequence for the backside hangers is shown in the illustration below. The lock-washer contacts directly with the enclosure, then the hanger, the flat washer, and lastly the screw to secure. Tighten the screw until snug, but do not over-tighten.

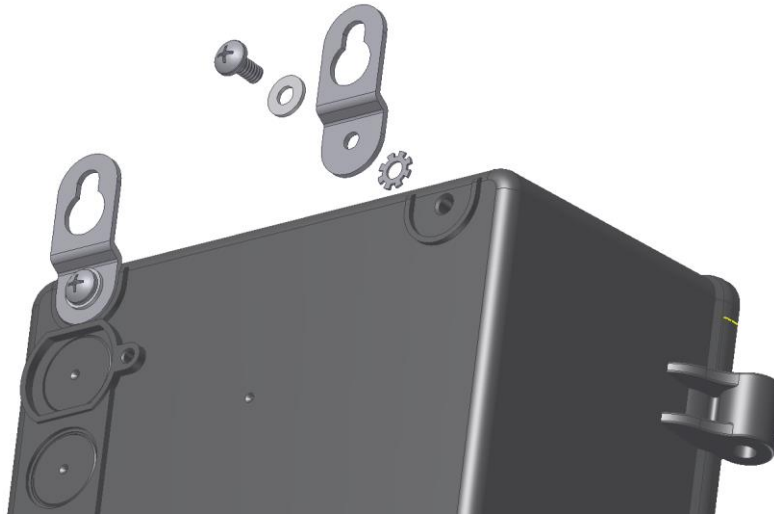

Wall Mount Hangers Assembly Sequence

Vertical Pipe Mounting

Another mounting option available for the CNI2 is the pipe-mount. This adaptor will accept a 2 3/8" (2.375") diameter galvanized pipe, and is secured in place with a pair of Allen-head set-screws.



Pipe Mounting using Collar

Illustrated below is a U-Bolt mounting option. This is optimized for metal pipes with an outside diameter of 2 $\frac{3}{8}$ " (2.375").

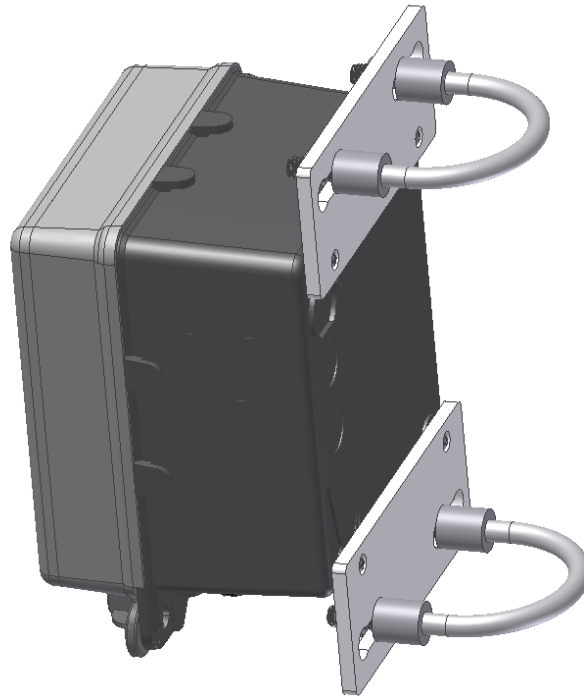

Pipe Mounting using U-Bolts

Index Mounting

Where it is desired to have an index base mounted directly to a meter, the UMB (Universal Mounting Bracket) option is available. The advantages of this package are that the entire instrument can be mounted without any concerns about routing external meter pulse signal wires. Mounting of the UMB index base is possible on rotary, turbine, and diaphragm gas meters that have a rotating instrument drive output. This includes American, Rockwell, Romet, Roots, or Schlumberger meters.

The UMB housing may be rotated about the base plate so that the instrument and index will face in any of the four directions. Remove all four screws which attach the base plate to the bracket housing. Replace and tighten the four screws after you have repositioned the UMB housing.

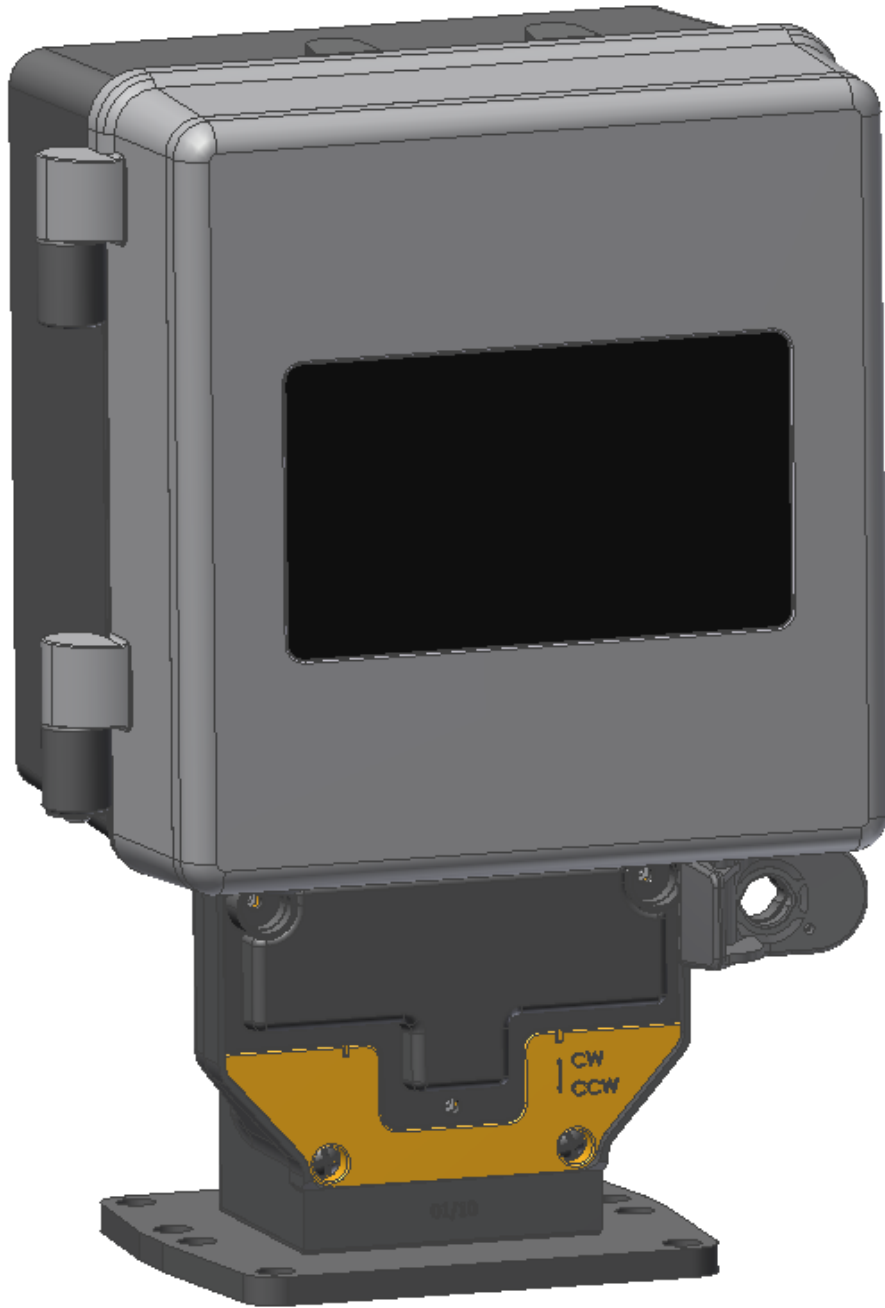

CNI2 with Universal Mounting Bracket (UMB)

The bottom side of the UMB meter index is seen below, along with the 'wiggler' mechanism.



Bottom View of the Universal Mounting Bracket (UMB)

The following illustration provides reference dimensions for the base plate.

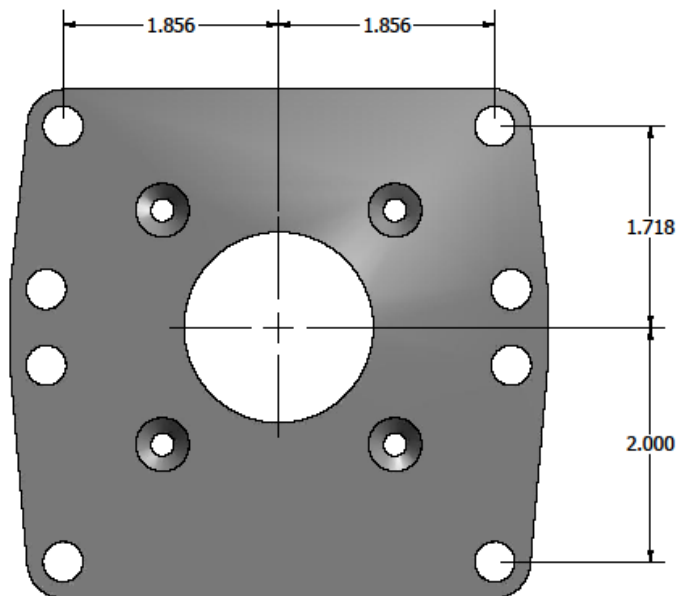

Universal Mounting Bracket (UMB) Hole Pattern

Illustrated below is the UMB index without the front covers or enclosure housing. It may be necessary to change the direction of rotation to match that of the meter. Remove the three screws from the transparent cover, and then remove the cover.

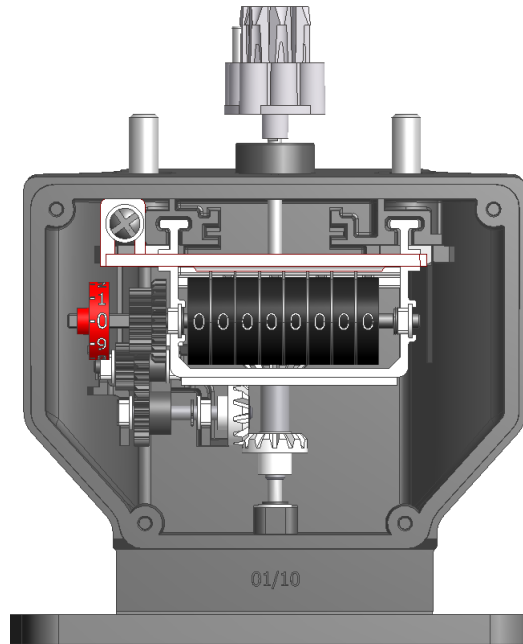

Internal View of the Index Base

A small tool is included with the index, under the transparent cover. Loosen the set screw in the middle of the gear shaft. Shift the gear set upwards for meters with CW rotation and down for meters with CCW rotation. See the gear detail drawing below. After the gears are securely set, check for good gear engagement that is neither too loose (causing gear skipping) or too tight (causing gear binding). Then reinstall the transparent cover.

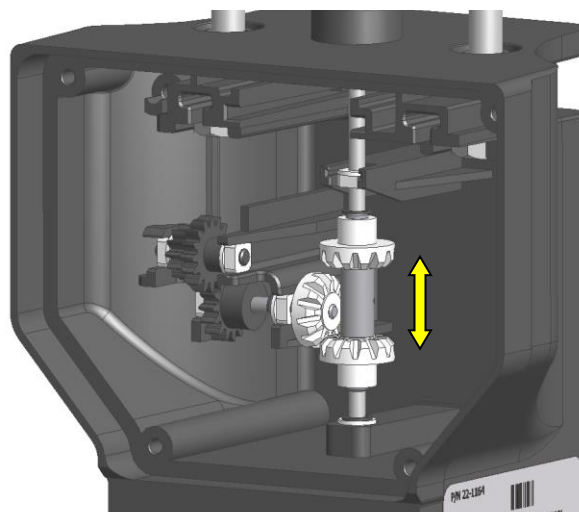

Rotation Gears within the Index Base

As a final note, it is also possible to change the number of digits visible on the mechanical odometer using horizontal sliding “windows”. Up to three digits can be masked-off from the right side, and/or up to three digits from the left side.

When the UMB is included with the instrument, a rotating magnet and several magnetic sensor switches will be present inside the enclosure as seen below. For convenience, wires from the sensor switches are pre-wired from the factory to the pulse counting input terminal block on the CNI2. In the unlikely event that one of the two reed switches should fail, the redundant input channel will continue to register accurate counts.

The illustration below shows the CNI2 with the rotary magnet and dual reed switches. For clarity the illustration above does not show the routing of wires from the sensor switches.

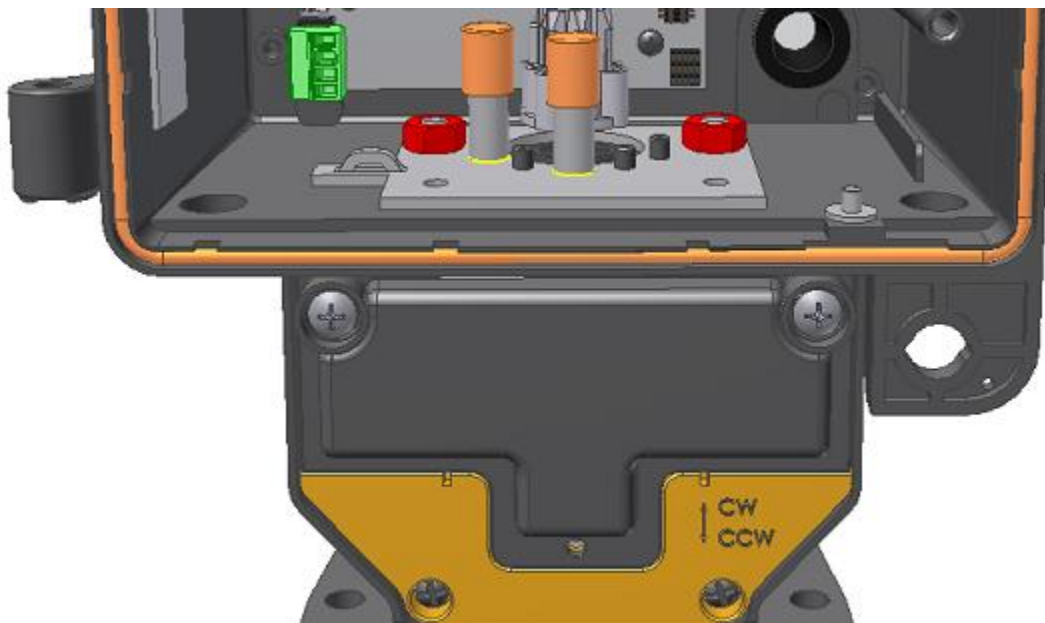

Index Base with Magnetic Switches

Another option is the Uncorrected Pulse Output board, as seen below. This provides an additional dry-signal pulse output that can be connected to an external pulse counting instrument. For clarity this illustration does not show the routing of wires from the sensor switches.

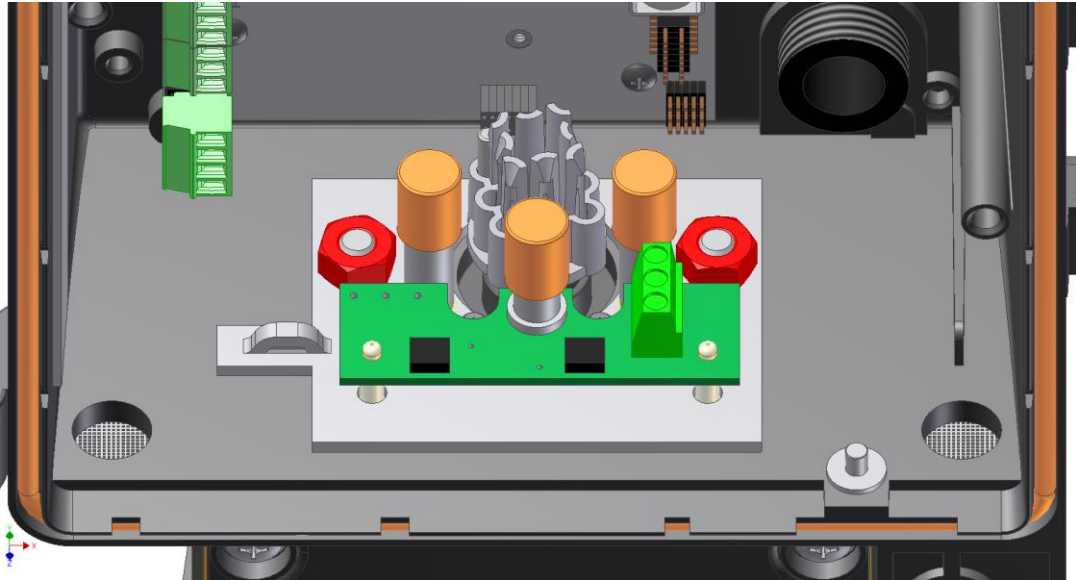

Pulse Output Board

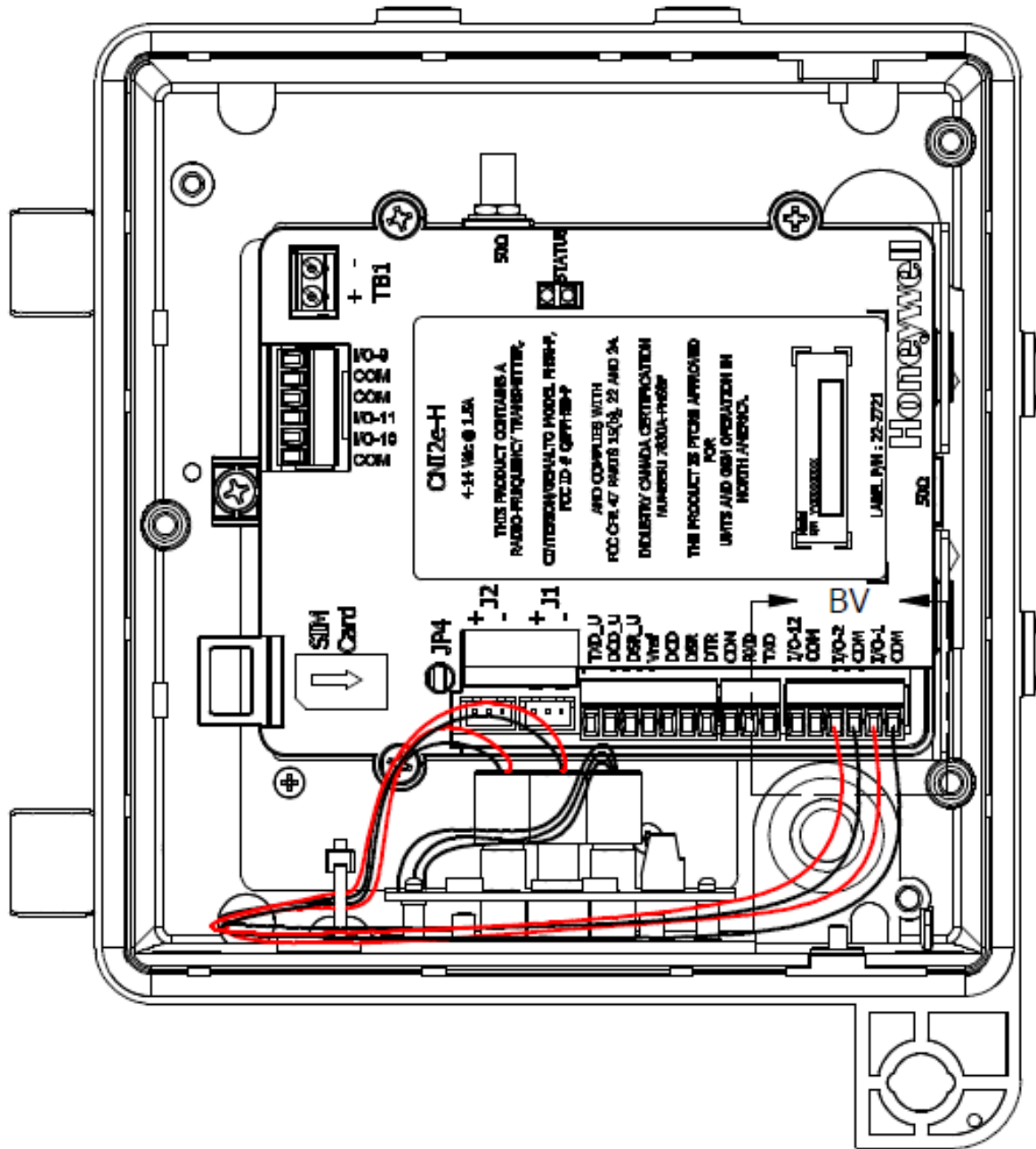

UMB Magnetic Switch / Pulse Output Wiring

ENCLOSURE SEALING

Sealing of the enclosure is readily accomplished using either a conventional lock through the larger hole or a security wire seal through the smaller hole.

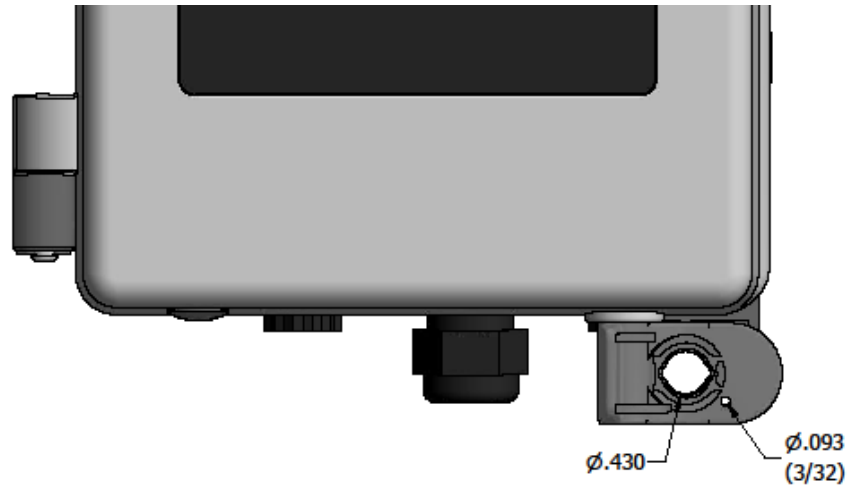

Enclosure Sealing Options

TAMPER DETECT & CALL SWITCH OPTIONS

The photo below illustrates where two magnetic switches are located within the CNI2. At the bottom left corner is the “CALL” switch. This allows the field technician to initiate a call without the need to open the door of the unit. A hand-held magnetic wand is simply placed against the outside of the enclosure for a few seconds.

The TAMPER detect switch is seen on the outside wall (the actuating magnet is attached to the door). When the door is opened the switch activates and can generate an immediate call into the central office, or the event will be reported on the next scheduled call.

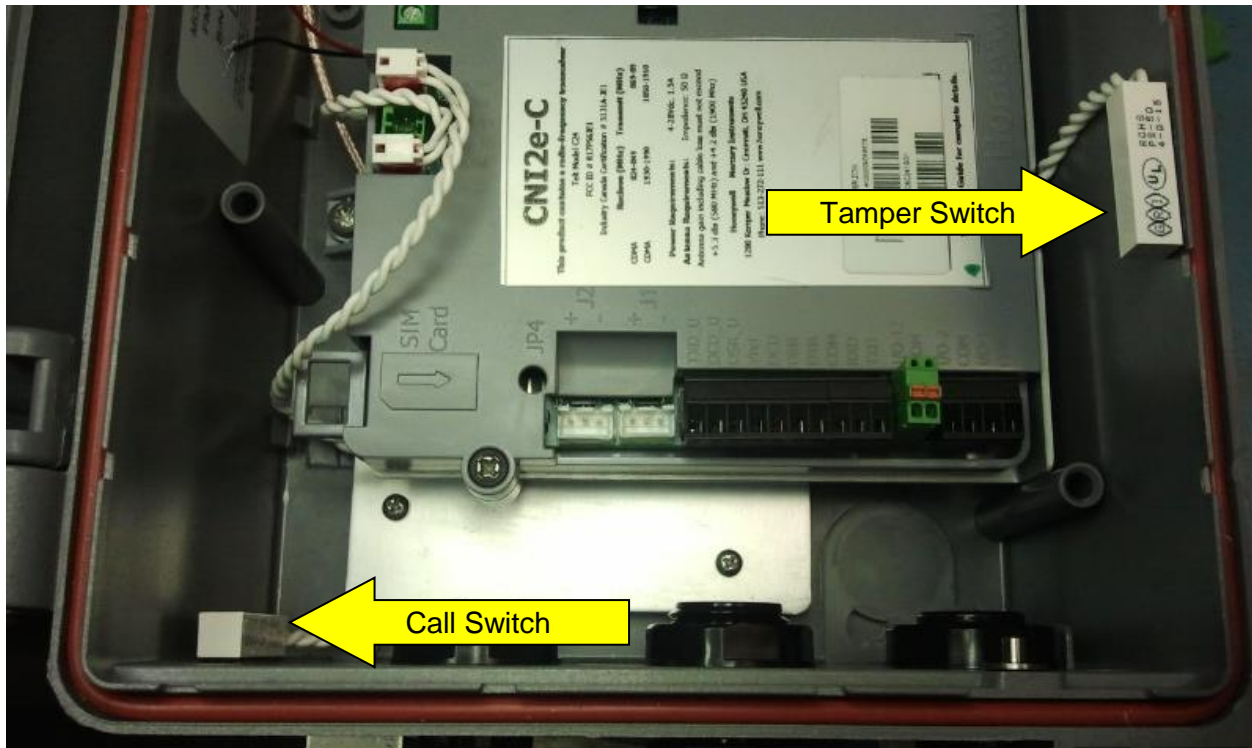

Locations of Tamper and Call Switches

INTERNAL BATTERIES

Several battery configurations are available. Shown below is the dual-cell lithium power pack. This pack inserts onto the enclosure door with the right-side of the metal plate tilted inwards first, and then snapping secure on the left side. Removal is the opposite, and it is a simple matter of pressing outwards against the plastic latch to release the plate.

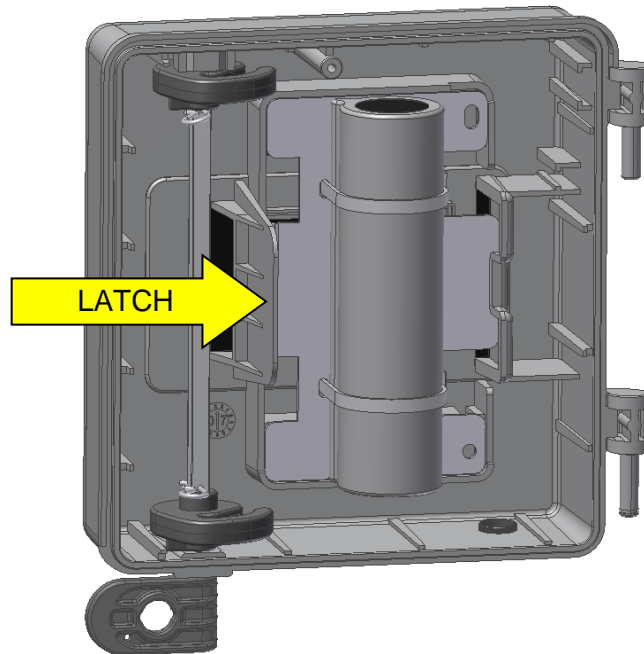

Lithium Battery Pack Mounting

A larger quad-cell lithium pack is also available for double the capacity of the dual cell type. Refer to the specifications section at the end of this manual for a comprehensive listing of battery pack options and their part numbers.

Alkaline battery packs are available in either disposable form, or with a molded plastic housing that permits replacement of individual 'D' cells. The next illustration shows the plastic housing model mounted onto the enclosure door. Although the molded battery housing has a higher initial cost, it offers the advantage of obtaining replacement batteries from numerous local suppliers.

NOTE

When replacing alkaline batteries, only use new fresh cells from the same supplier and having equivalent part numbers. Do not mix alkaline and carbon batteries.

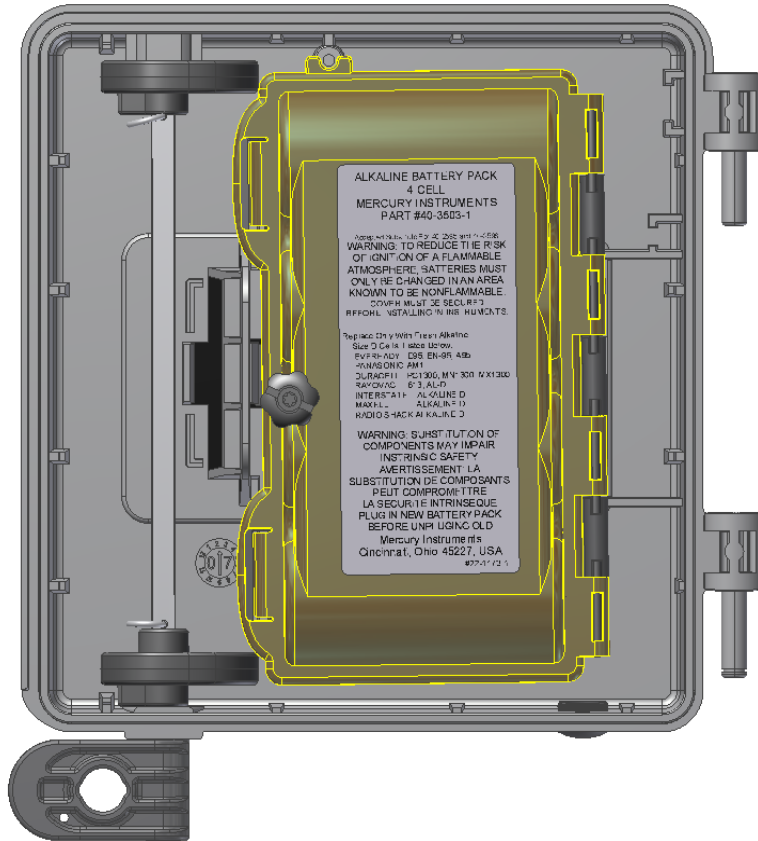

Replaceable Alkaline Battery Pack Mounting

Alkaline cells are also available in a completely disposable package option. After the service life of the battery pack has expired, dispose of the entire assembly, including the metal bracket.

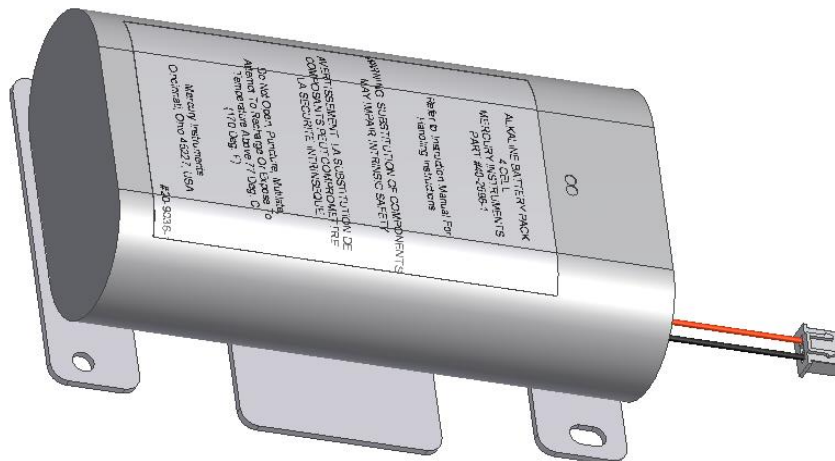

Disposable Alkaline Battery Pack

Refer to the specifications section of this manual, or the control drawing for a compiled listing of approved battery packs.

To avoid loss of system power to the CNI2 board during battery changes, it is recommended that the fresh batteries be connected to the available J1 or J2 connector before removal of the old battery pack. This is a hot swap method that is permitted for the brief period during which batteries are to be replaced.

IMPORTANT NOTE

Physical space is not available within the enclosure to permit two battery packs to be permanently installed simultaneously. In addition, parallel battery packs would violate hazardous area safety approvals for this product.

IMPORTANT NOTE

Complete loss of power will cause the CNI2 to lose pulse-counting and time information.

RESERVE CAPACITOR

As mentioned in an earlier [section](#) a reserve (super) capacitor is required when using alkaline or lithium batteries. The capacitor is attached to the bottom mounting plate.

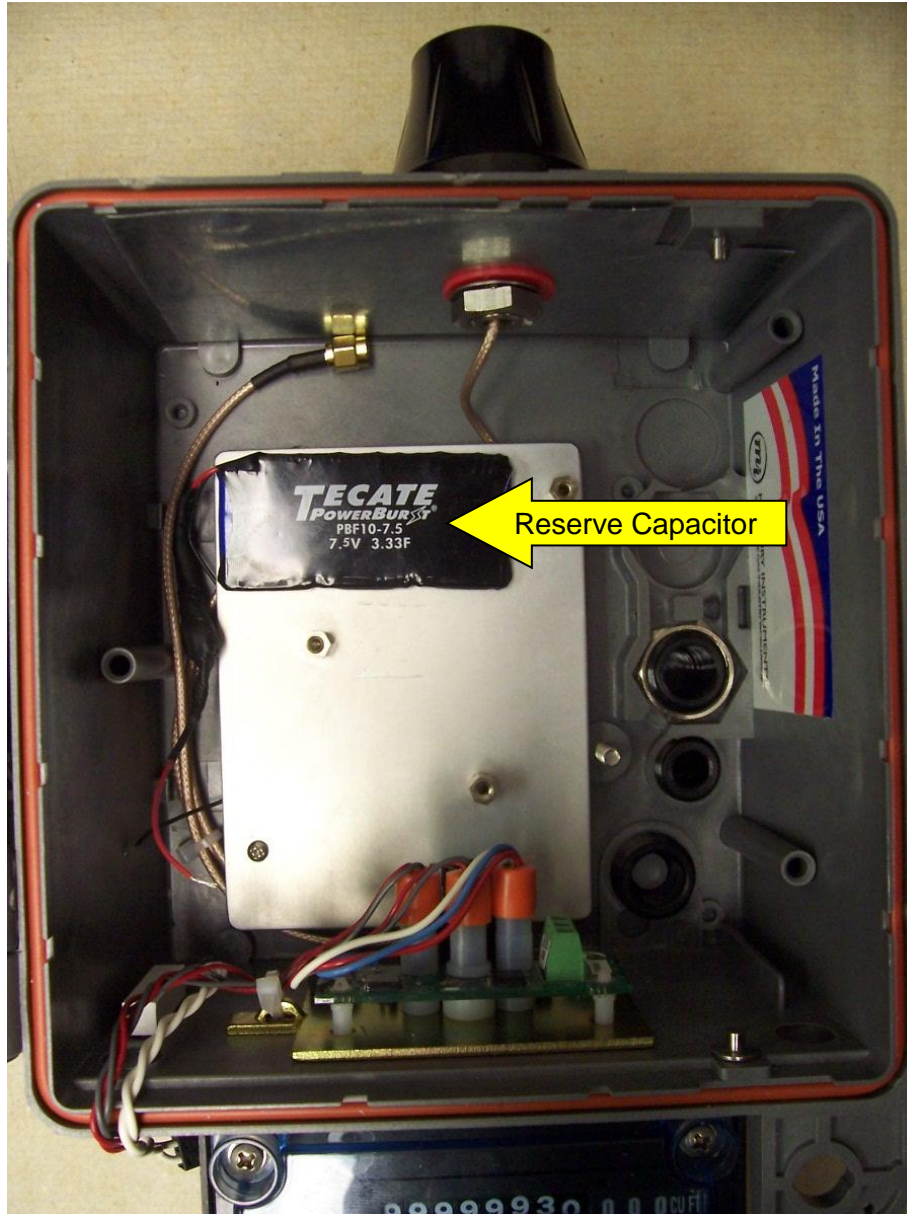

Location of the Reserve Capacitor

AC-POWER WITH BATTERY BACKUP

Applications that require the cellular radio to be powered-up on a full-time or near-full-time basis may require a solar or ac-power source. There is also an optional disposable lithium power pack that allows for uninterrupted service during power outages. These packs are mounted to the door in the same fashion as the previously-mentioned battery packs.

To make the best use of the backup battery pack, see the section titled [“Power Preservation Mode”](#)

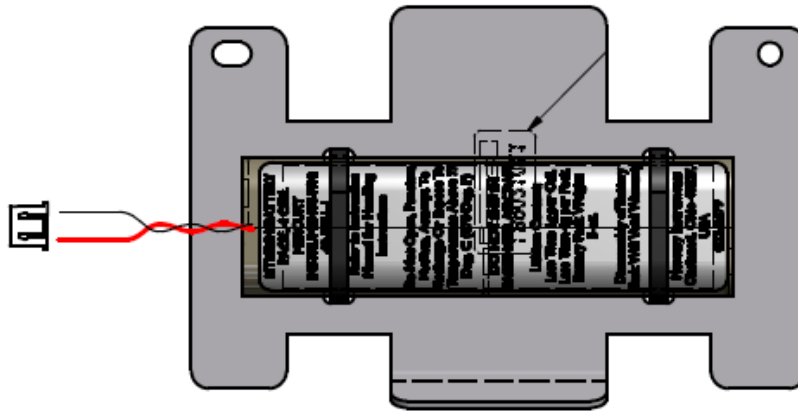

40-5551-1 Lithium Backup Battery Pack

AC POWER SUPPLY REQUIREMENTS

- External power sources must be CSA/UL certified / recognized as Class-2 (UL1310).
- 7.5 to 14 Vdc, 1000 mA minimum output, ability to handle 1.8A / 0.5 mS peaks.
- 120 VAC, 60 Hz input (preferably 90 to 270 VAC, 50-60 Hz to meet the needs of the global community).
- -30°C to + 70°C operating temperature range.
- Less than 2% ripple.
- Short circuit protection.
- Regulated output preferred.

AC POWER SUPPLY RECOMMENDATIONS

We recommend the following ac-to-dc adapter made by Meanwell. This power supply requires an enclosure and adherence to all electrical codes.

Model	Output voltage	Output Current	Ingress
Meanwell LPV-20-12	12 Vdc	1.67 A	IP67

This has a CSA C22.2 rating and a 90-270 VAC, 50-60 Hz input range.



Meanwell LPV-20-12 Power Supply

Honeywell also supplies the assembly shown below preassembled with a U.S. (120 VAC) plug and 6' (1.8m) of cable on the dc output. This is assembly 40-5589 and utilizes the Meanwell power supply mentioned earlier. It is included in the installation kit 22-2703 which includes instruction sheet with system installation drawing and instructions. This power supply requires an enclosure and adherence to all applicable electrical codes.

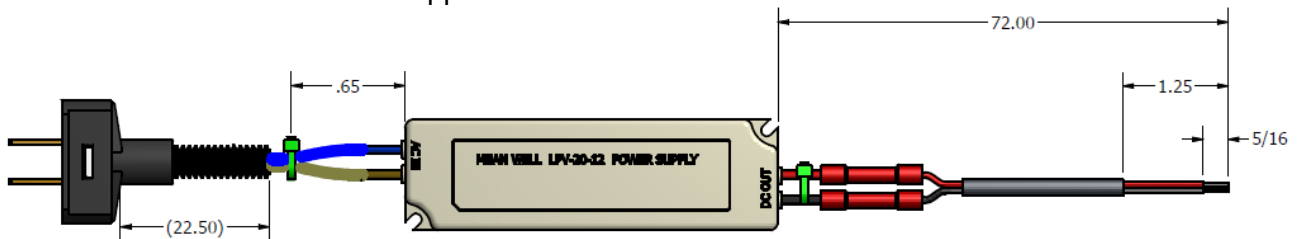

40-5589 Power Supply Assembly

The unit will come pre-wired for connection to an external power supply. A 2-position terminal block is located in the lower left corner. See the next illustration. Observe proper polarity.

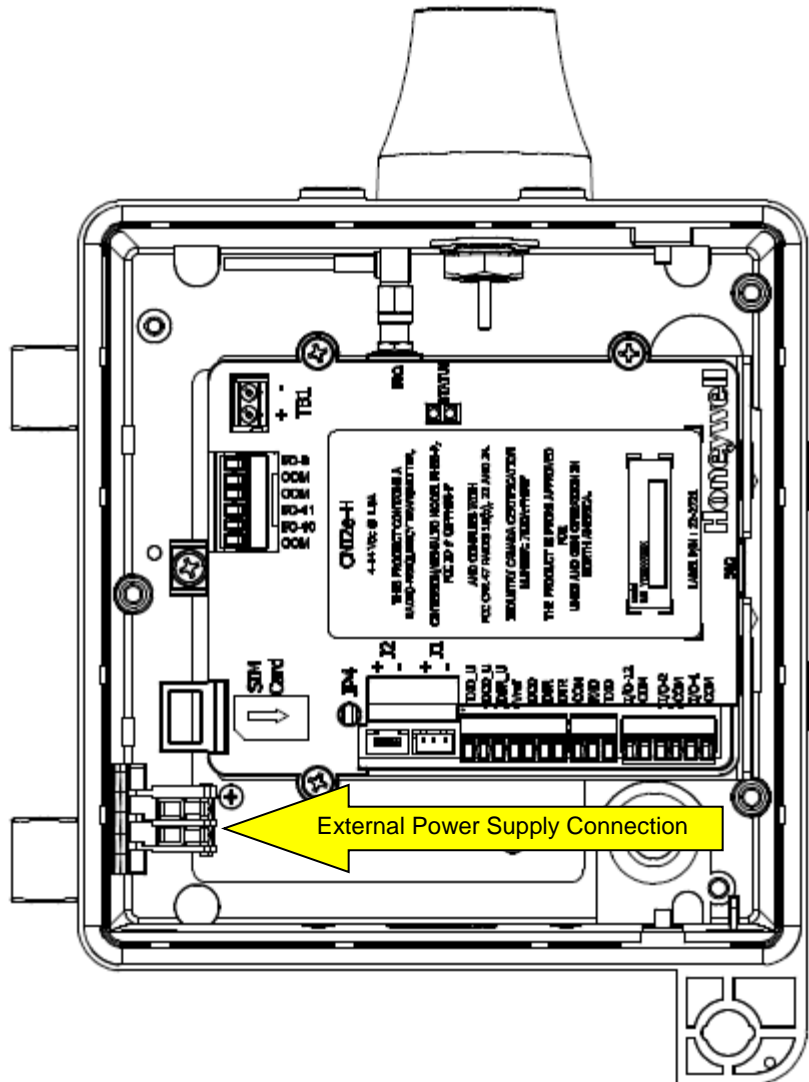

External Power Supply Connection

CAUTION
Never use the reserve capacitor when using an external power source!

SOLAR POWER CONFIGURATION

If using solar power it will be necessary to provide a voltage charge regulator and a lead acid battery as seen in this illustration. Wiring to the terminal block will be the same as was the case for the [AC power](#) application. The lead acid battery serves as the backup source during the evening and cloudy days. Correct sizing of the solar panel and lead acid battery are necessary for a given territorial region. Application notes are available from solar panel suppliers to assist in the process of sizing the panel and battery.

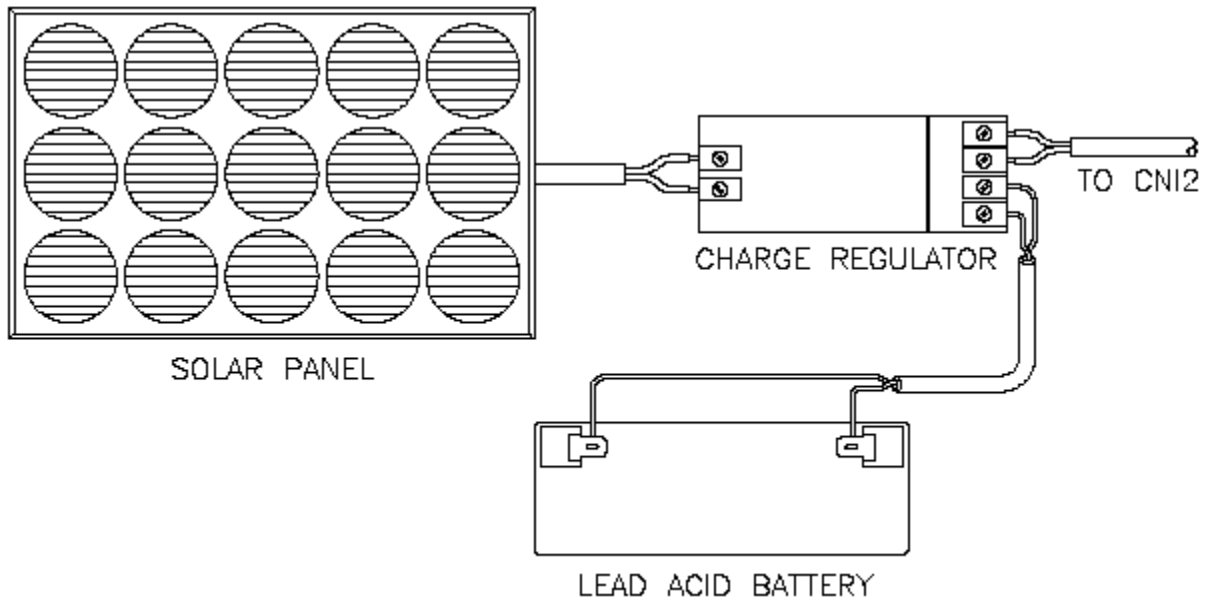

Typical Solar Power System

Obtaining maximum power from the solar panel can only be achieved if it has been properly adjusted with the collector surface pointed towards the correction direction, and then adjusted for the sun's altitude. The correction direction is the direction of the sun at "solar noon". "Solar noon" is when the sun is at its maximum altitude relative to the south horizon and equidistant between the east and west horizon. The altitude and solar noon changes each day throughout the year as the earth orbits the sun. There are several internet-based calculators that can provide this information. Some require the latitude and longitude for your location while others only need the name of your city or a zip code.

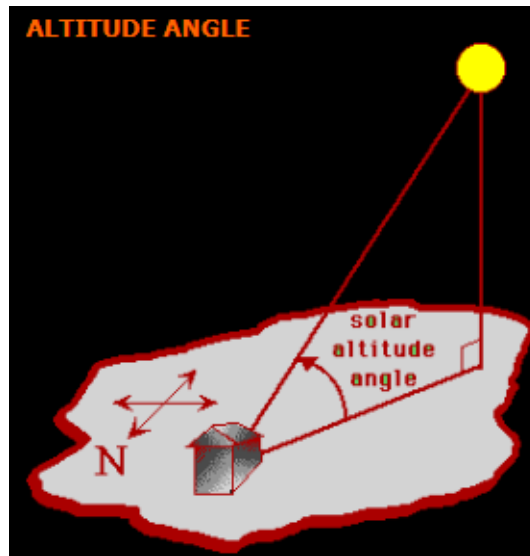

Solar Altitude

The solar panel should always face south for all locations north of the equator, and vice-versa if south of the equator. Solar panel tilt angle will vary depending upon the latitude of the installation location. The angles listed below are calculated to provide optimum energy production during the winter months when solar radiation is at its weakest. A map is also provided to allow determination of the latitude for a given point in the United States.

<u>Latitude</u>	<u>Tilt Angle</u>
15°	15°
20°	20°
25°	25°
30°	35°
35°	45°
40°	55°
45°	65°
50°	70°

Typical Solar Panel Tilt Angles

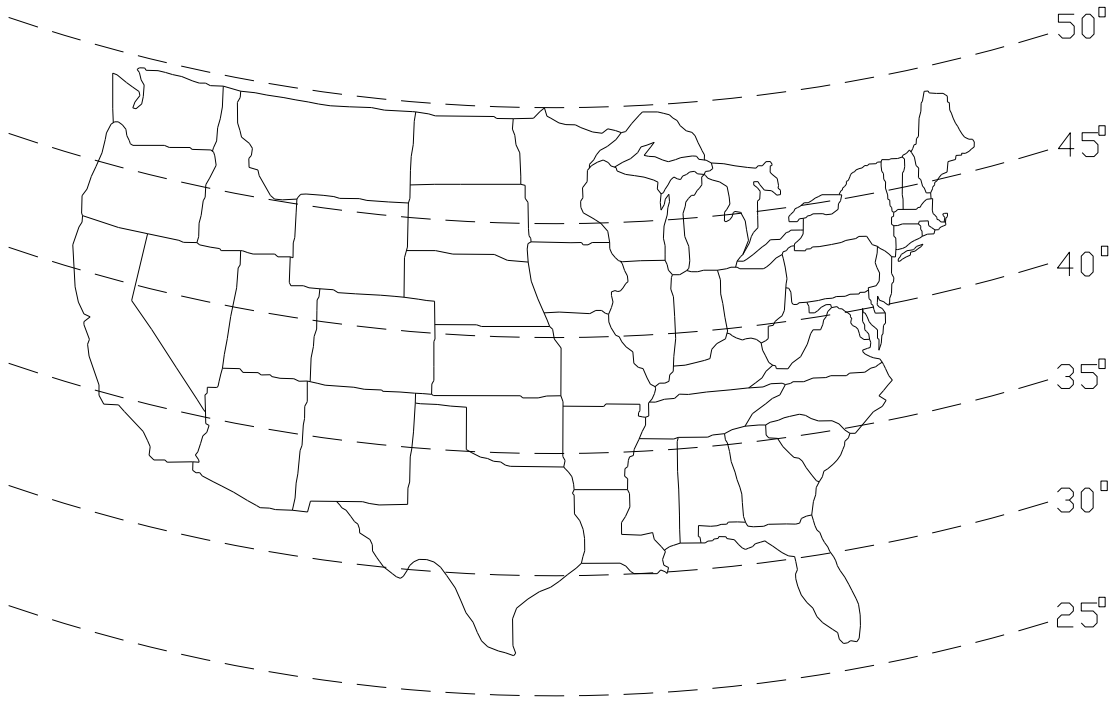

Latitude Map of the United States

Measurement of the tilt angle can be accomplished with a combination square utilizing a protractor head attachment. These tools are available from numerous sources including Starrett, Brown & Sharpe, Mahr, Mitutoyo, etc.

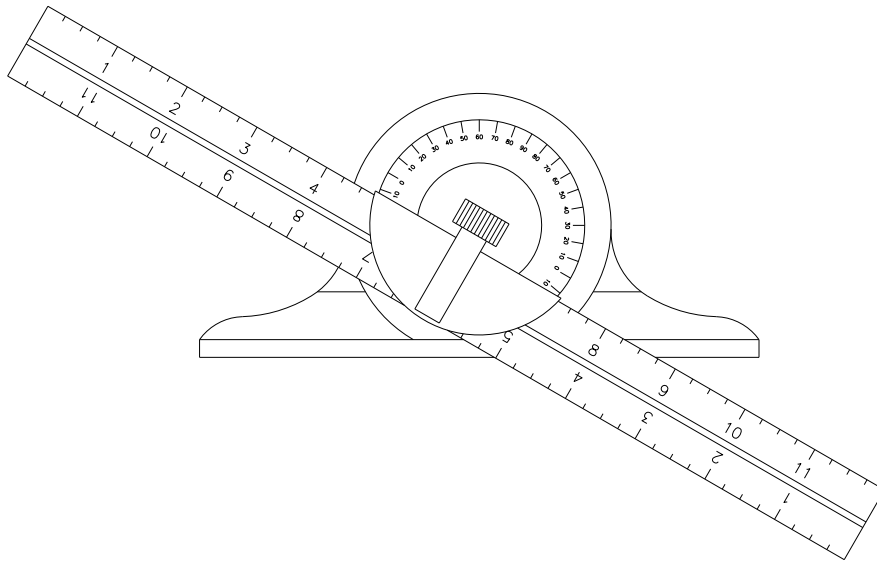

Combination Square with Protractor Head

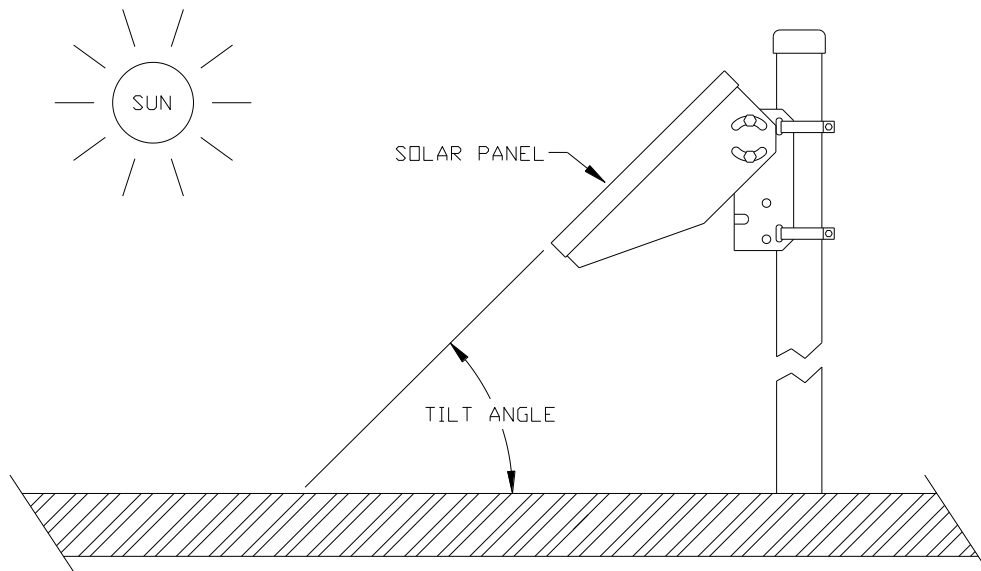

Solar Panel Tilt Adjustment

Another approach is to monitor the output of the solar panel with a voltmeter and adjust for a peak reading at solar noon, preferably around the winter solstice (December 21). You may have to temporarily disconnect the solar panel from the controller to do this. Some "12V" panels will generate voltages as high as 22V at solar noon.

ELECTRICAL ASSEMBLIES

CNI2E-H CIRCUIT BOARD

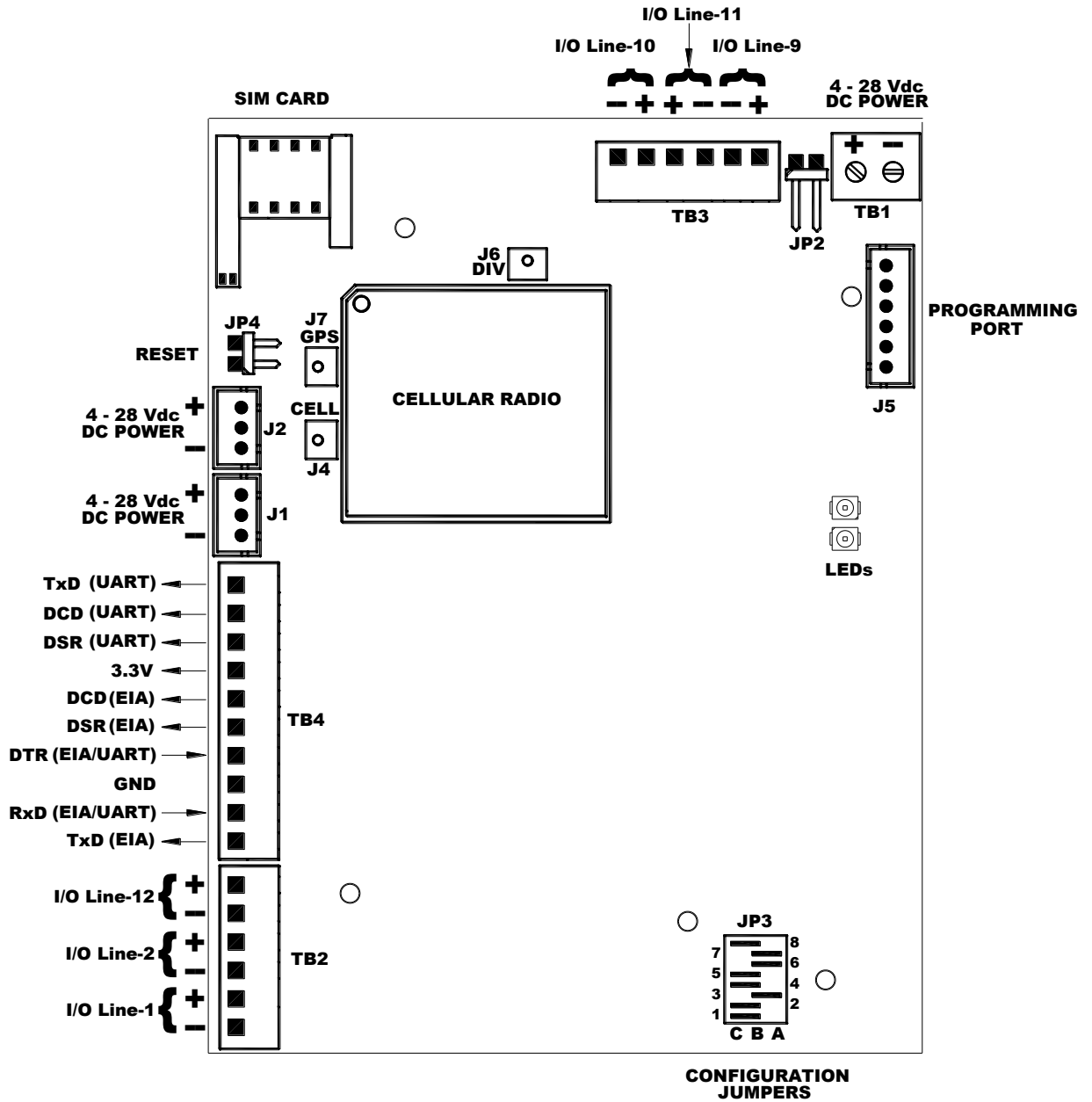

CNI2e-H Circuit Board

Cellular Radio Module

The cellular radio module is manufactured by Gemalto (Cinterion), model PHS8-P. This module supports both UMTS/HSPA and GSM/GPRS on five cellular bands: 850, 900, 1800, 1900 and 2100 MHz. HSPA operation may not be compatible with some of T-Mobile's North American HSPA (3G) services. However the CNI2e can be used on all of T-Mobile's North American GSM (2G) services.

SIM Card Socket

This connector holds the cellular radio SIM card.

Reset Jumper JP4

If it is necessary to perform a complete reset operation, use a small blade screwdriver or coin to momentarily short out the two pins of JP4.

NOTE:

A reset will cause all pulse data to be lost and the unit's time-of-day to be reset.

Power Connectors J1 & J2

These connectors are intended for connection to 4-28 Vdc power sources. Both connectors are identical in function, and allow for the hot-swap of batteries without the loss of power to the board.

See a previous discussion about the use of super-capacitors. When a super-capacitor is connected to the TB1 terminal block the voltage on J1 or J2 must not exceed 7.5V.

Terminal Block TB1

This terminal block serves as a third connection point for power. It also allows a super-capacitor to be used to supplement battery systems that can't normally provide enough power for the radio. See a previous discussion about the use of super-capacitors.

Terminal Block TB4

Terminal block TB4 provides for connection to the serial port. There is more information about the serial port later in this document. The term "EIA" refers to RS-232 level signals ($\pm 5.5V$) whereas the term "UART" refers to logic-level (+3.3V) signals.

Terminal Block TB2

Terminal block TB2 is a connection point for three of the pulse-counting or alarm-sensing inputs, or control / replicator outputs. There is more information about these lines later in this document.

Terminal Block TB3

Terminal block TB3 is a connection point for three of the pulse-counting or alarm-sensing inputs, or control / replicator outputs. There is more information about these lines later in this document.

Connector J5

This is the programming port connector.

Connector J4

This is the connection point for the cellular antenna.

Connector J7

This antenna connection is not currently used.

Connector J6

This antenna connection is not currently used.

Jumper JP2

When connecting a power source to the TB1 terminal block, JP2 should be open (no shorting block installed).

When attaching a super-capacitor to the TB1 terminal block, JP2 should have a shorting block installed.

JP3 Jumper Settings

Manipulation of these jumpers allows for special operating modes and test functions. See the next illustration.

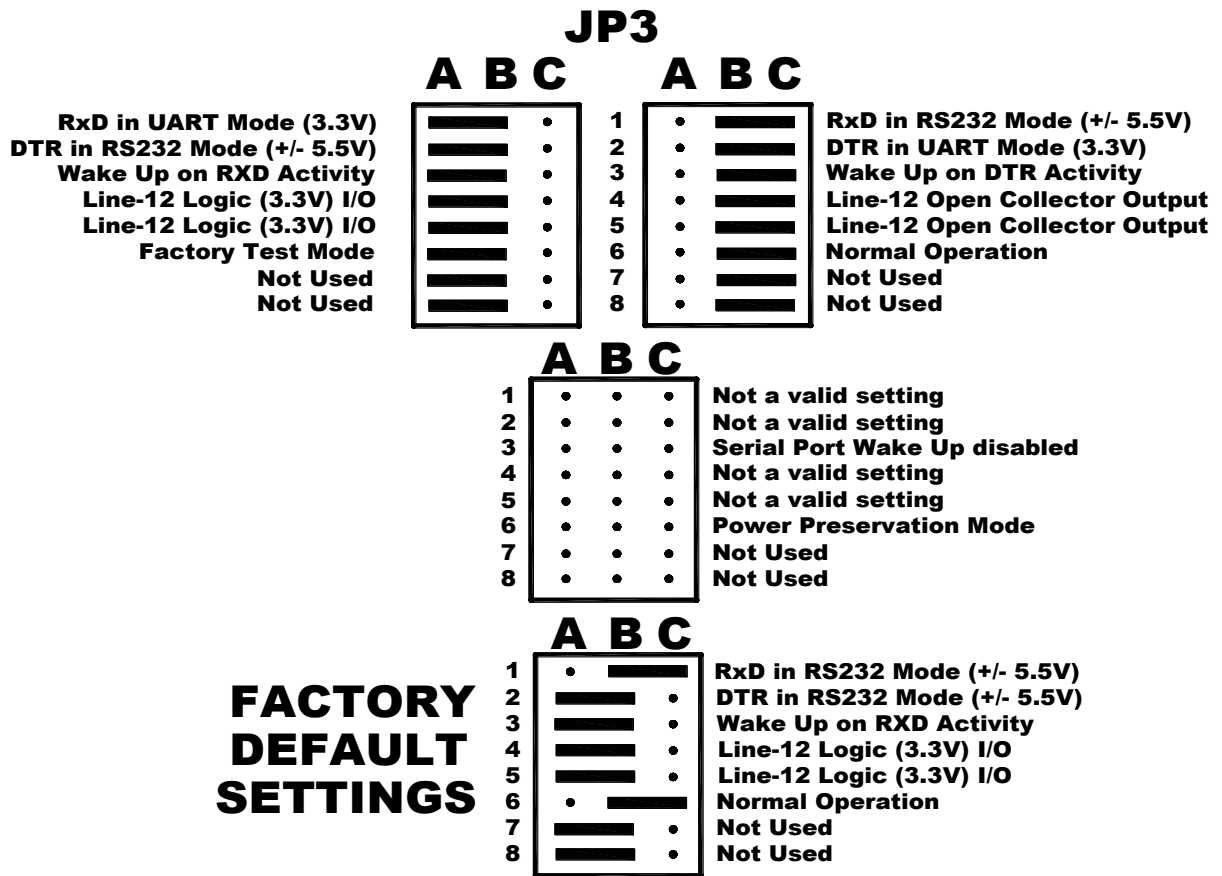

JP3 Configuration Jumpers (CNI2e-H)

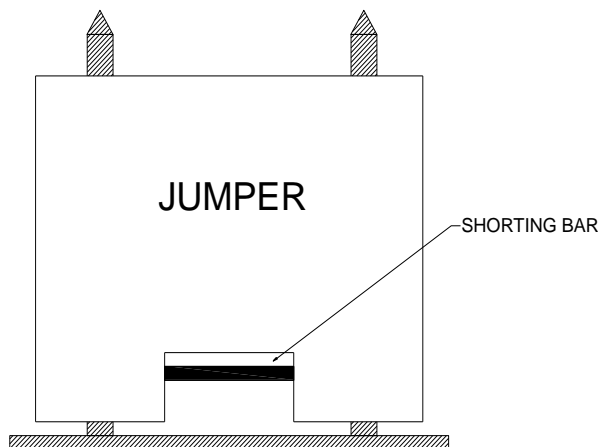

Proper Orientation of JP3 Jumpers

CNI2E-C CIRCUIT BOARD

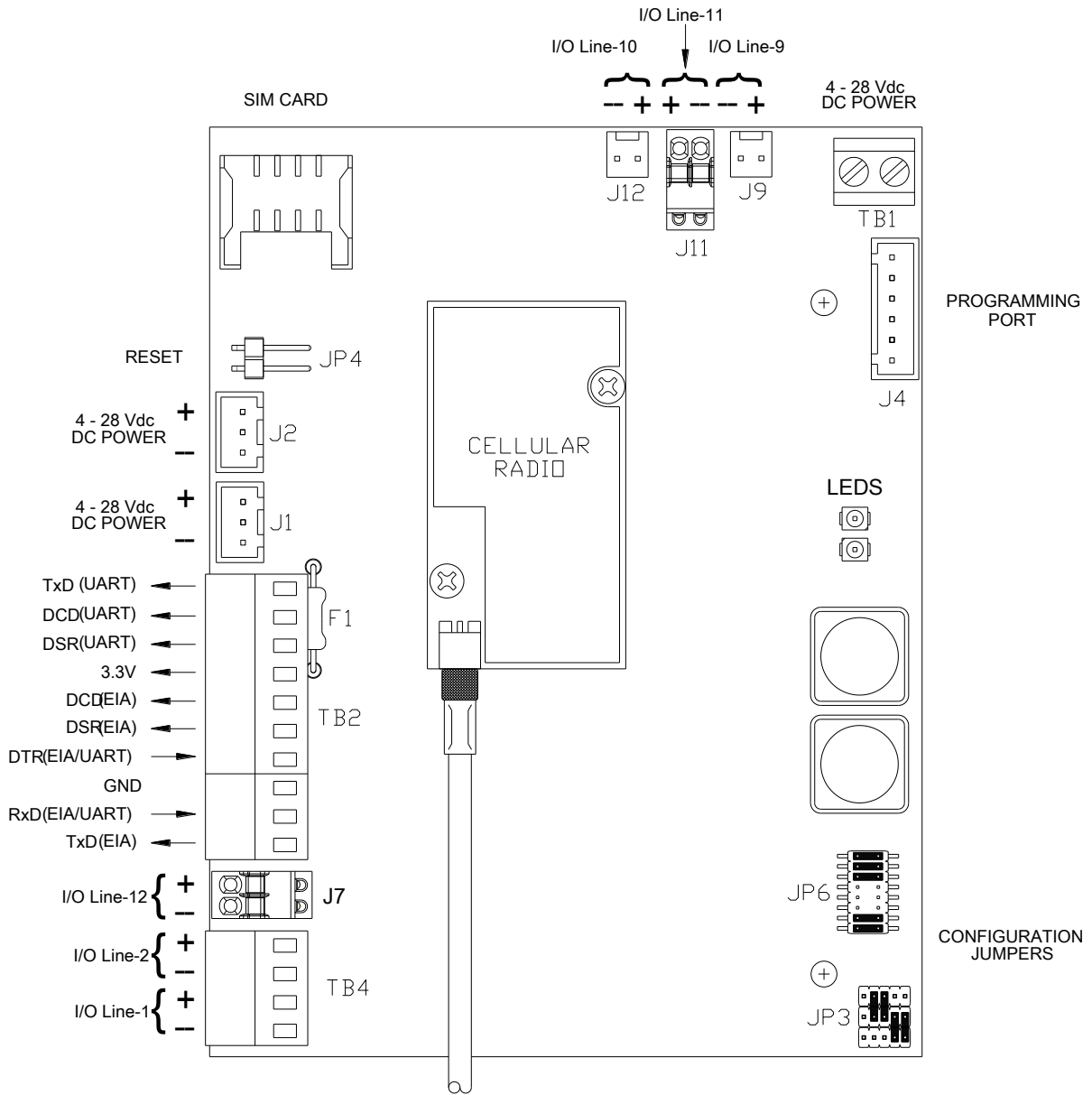

CNI2e-C Circuit Board

Cellular Radio Module

The cellular radio module is manufactured by Telit, model c24. This module supports CDMA/1X service on two cellular bands: 850 and 1900 MHz. There is a different model for Verizon and Aeris. Sprint is not supported.

Verizon	Aeris
F8005xxx	F8014xxx

SIM Card Socket

The SIM connector is not used in this configuration.

Reset Jumper JP4

If it is necessary to perform a complete reset operation, use a small blade screwdriver or coin to momentarily short out the two pins of JP4.

NOTE:

A reset will cause all pulse data to be lost and the unit's time-of-day to be reset.
--

Power Connectors J1 & J2

These connectors are intended for connection to 4-28 Vdc power sources. Both connectors are identical in function, and allow for the hot-swap of batteries without the loss of power to the board.

See a previous discussion about the use of super-capacitors. When a super-capacitor is connected to the TB1 terminal block the voltage on J1 or J2 must not exceed 7.5V.

Terminal Block TB1

This terminal block serves as a third connection point for power. It also allows a super-capacitor to be used to supplement battery systems that can't normally provide enough power for the radio. See a previous discussion about the use of super-capacitors.

Terminal Block TB2

Terminal block TB2 provides for connection to the serial port. There is more information about the serial port later in this document. The term "EIA" refers to RS-232 level signals ($\pm 5.5V$) whereas the term "UART" refers to logic-level (+3.3V) signals.

Terminal Block TB4

Terminal block TB4 is a connection point for two of the pulse-counting or alarm-sensing inputs, or control / replicator outputs. There is more information about these lines later in this document.

Connectors J7 and J11

J7 and J11 are connection points for two of the pulse-counting or alarm-sensing inputs, or control / replicator outputs. There is more information about these lines later in this document.

Connectors J9 and J12

J9 and J12 are connection points for two of the pulse-counting or alarm-sensing inputs, or control / replicator outputs. There is more information about these lines later in this document.

JP3 Jumper Settings

Manipulation of these jumpers allows for special operating modes and test functions. See the next illustration.

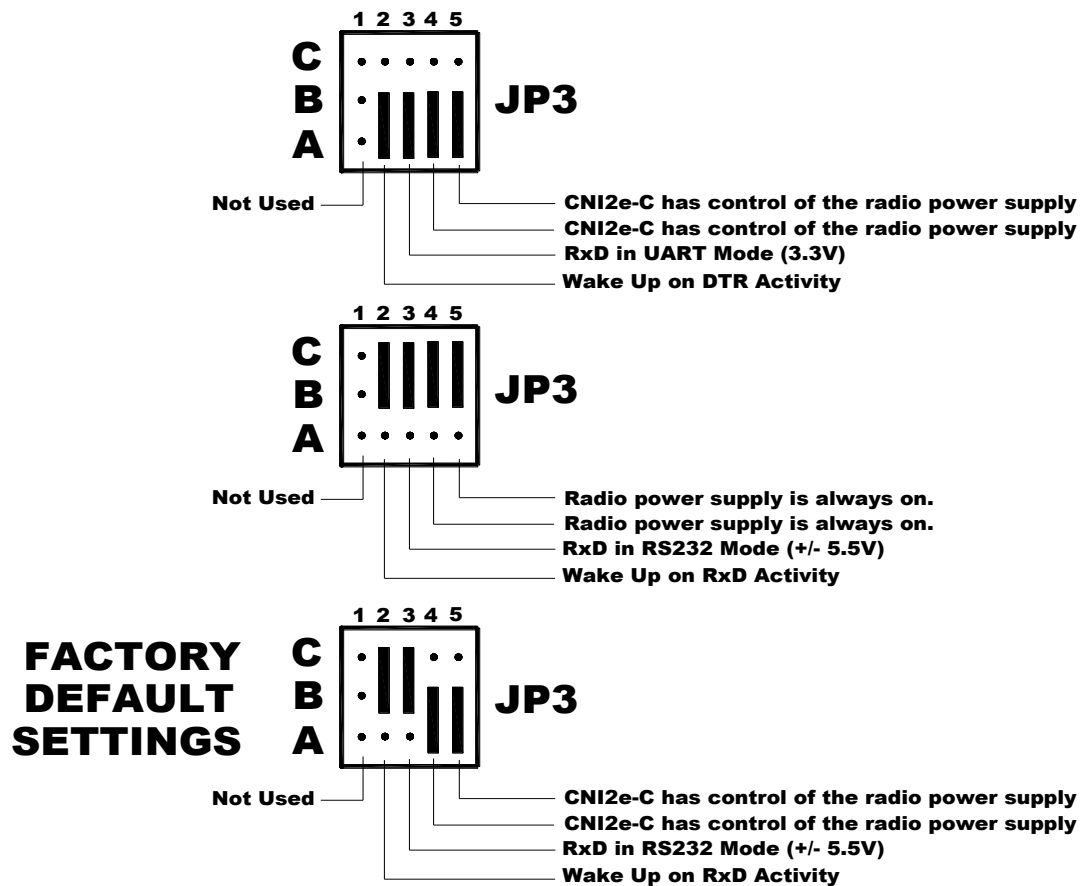

JP3 Configuration Jumpers (CN12e-C)

JP6 Jumper Settings

Manipulation of these jumpers allows for special operating modes and test functions. See the next illustration.

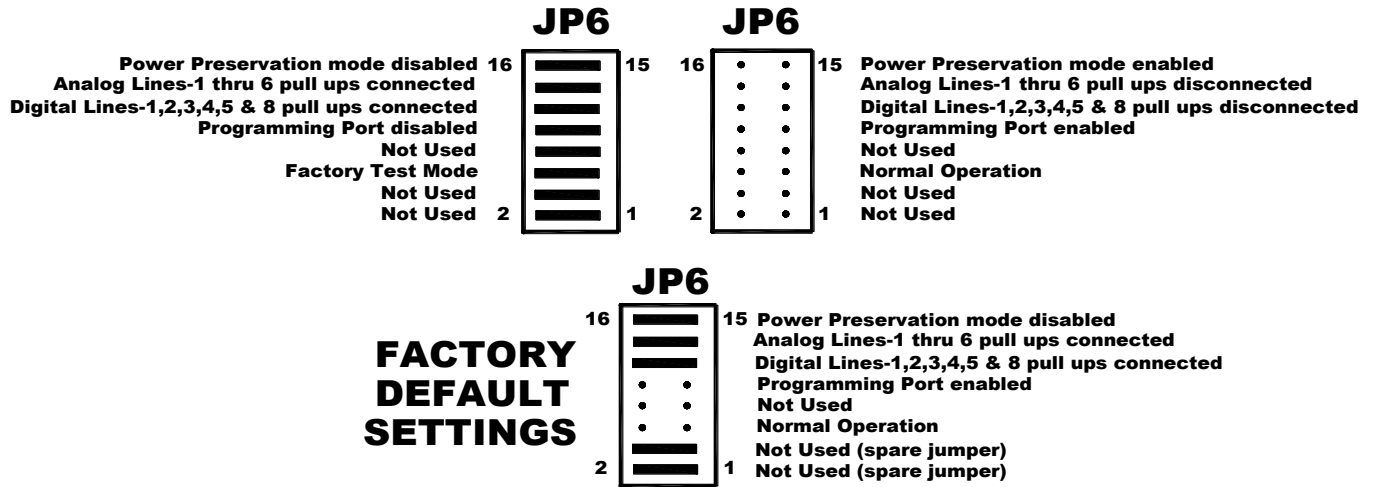

JP6 Configuration Jumpers (CNI2e-C)

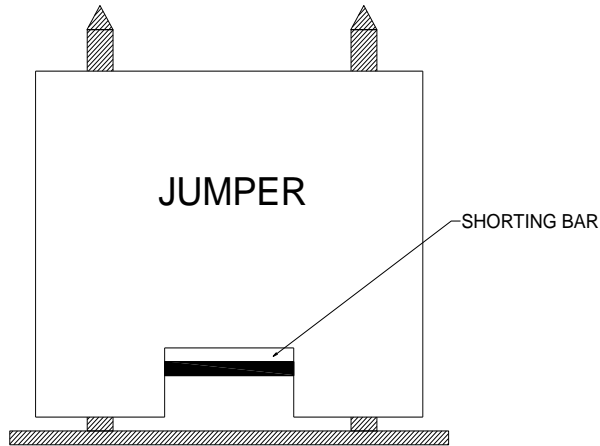

Proper Orientation of JP3 and JP6 Jumpers

DIGITAL SIGNAL INPUTS & OUTPUTS

There are a total of six digital signals on the CNI2e board that can be used as alarms, status inputs, pulse-counting inputs or control outputs.

Each signal has a “line number” assigned to it and these are referenced within MP32. There is more information about inputs and outputs in the [“Programming”](#) section of this manual.

Alarm / Pulse Inputs

Any of the six digital signals can be used as alarm or pulse-counting inputs. These can be configured in a number of ways using the MP32 configuration program. Later in this document is a technical discussion about how each input is processed.

Any line acting as an input can be configured as Form-A (normally open), Form-B (normally closed) or Form-C (one of each, sometimes called “KYZ”). When configured as Form-C the lines are grouped together as follows:

Lines-1 & 2 Lines-9 & 10 Lines-11 & 12

In Form-C configurations alarm-sensing or pulse-counting is performed on the first line of each pair (Lines 1, 9 and 11). These lines should be the normally-open (Form-A) side of the switch. Lines-2, 10 and 12 are used to detect if the switch has failed or a line has been cut. These lines should be the normally-closed (Form-B) side of the switch. If both lines appear open or closed at the same time this is considered a failure. In some configurations this will be reported to the host system.

All lines are pulled up to the CNI2e’s logic power supply, which is 3.3V. Wetting current is 33 μ A (0.000033 A).

Alarm Input Assignments as a Metretek SIP or InvisiConnect Device

Some of the input lines have predefined functions when the CNI2e is configured as a Metretek SIP data logger or an InvisiConnect device.

Line-1

When Line-1 is configured as an alarm input it will be reported as “Customer Alarm-1”.

Line-2

When Line-2 is configured as an alarm input it will be reported as “Customer Alarm-2”.

Line-9

When Line-9 is configured as an alarm input it will be reported as “CALL” or “MAG SWITCH” alarm. This line is often connected to a magnetic reed switch that can be activated using a magnetic pen.

Line-10

When Line-10 is configured as an alarm input it will be reported as “TAMPER” alarm. This line is often connected to a magnetic reed switch that is activated when the enclosure door in which the CNI2e is mounted is opened.

Line-11

When Line-11 is configured as an alarm input it will be reported as an “AC-OFF” alarm when the input goes active and again as an “AC-ON” alarm when it returns to an inactive state. This is often used to indicate loss and restoration of the main power source.

Line-12

When Line-12 is configured as an alarm input it will be reported as “KYZ4” alarm.

Outputs

Any of the six signals can be configured as outputs. These are low-level (+3.3V) logic signals with very low current (2 mA) capabilities. In many cases these signals will need additional amplification or conversion by external equipment.

<p style="text-align: center;">WARNING</p>

<p style="text-align: center;">An output has strict limitations with respect to voltage and current. See the specifications section to avoid damage to the board.</p>

Line-12 on the CNI2e-H can be configured as a dry-contact (open-collector) output that can be pulled as high as 28Vdc. This is accomplished with two hardware jumpers on the [JP3 jumper block](#).

MP32 allows the outputs to be assigned different functions as follows:

- **Output Under Host Control:** This configuration can be used to control external equipment from the central office, such as a warning light, an audio alarm or a pump. This is only supported when the CNI2e is configured as a Metretek SIP and when using the “Relay Settings” feature in the PowerSpring® data collection system. The output is changed to the new setting only after a successful call.
- **Output Follows Input #”:** In this configuration the output follows any one of the inputs. This allows other external equipment to have access to the same pulse or alarm information that is being processed by the CNI2e.
- **Special Purpose Output:** This type of output is controlled by the CNI2e for special purpose applications. This is discussed in detail later in this document.

EXTENDING BATTERY LIFE

The CNI2e has been designed to provide long service life when operating from batteries. Total battery life is influenced by two factors in the CNI2e; continuous background current and high current draw during cellular calls. The background current can be minimized to a certain extent by using fewer pulse input connections and using normally-open (Form-A) contacts for pulse and alarm sensing. High current draw depends on the number and duration of cellular calls made. This can be minimized by ensuring the CNI2e has strong cellular reception (which minimizes call retries) and by limiting the number of regular scheduled calls to the extent practical.

LOW BATTERY DETECTION

The voltage level at which a low-battery condition is triggered can be specified using the MP32 programming software.

When the CNI2e is in low-power standby mode the power source must be low for at least 20 minutes before it is logged as a “real” low-battery condition. However if the “Power Preservation Mode” has been enabled, this time is reduced to 4 minutes.

During the time that the CNI2e is fully powered up the power source must be low for at least 2 minutes before it is logged as a “real” low-battery condition.

The CNI2e can be configured to place an immediate call when a low-battery condition is detected, or it can simply report the condition on the next call. When using the PowerSpring® data collection system you can define a “nuisance limit” that will prevent the CNI2e from calling in continuously to report a low-battery alarm. For instance if the limit is set to 2 then the CNI2e will only call twice to report the alarm between other calls (such as a scheduled call or a call generated by another alarm condition). Once the CNI2e calls in for another reason the “nuisance limit” is reset to 2 and the CNI2e is once again allowed to call in twice to report the low-battery alarm.

SERIAL PORT CONNECTIONS

In addition to processing alarms and pulse data, the CNI2e can act as a “transparent” modem. This allows the central computer to communicate directly with a device connected to the CNI2e’s serial port such as an electronic gas volume corrector or an electric meter

The serial port consists of signals with traditional EIA (RS-232) levels of $\pm 5.5V$. Recommended cable length should not exceed 15 feet (3m) and may need to be shorter at higher bit rates. All serial parameters are configurable using the MP32 configuration program.

There are also several non-inverted logic-level signals that are used to connect directly to other instruments that have a similar port. This is often referred to as a “UART” or “CMOS” port. These are low-current, non-inverted 3.3V signals. It is very important that the other instrument have the same voltages, otherwise damage may result on either end.

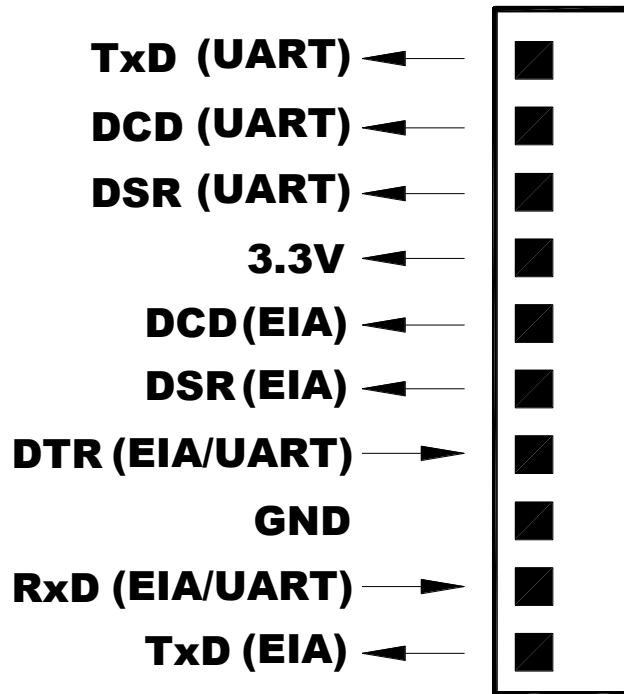

Serial Port Terminal Block

PROGRAMMING INFORMATION

Each CNI2e must be programmed with information that relates to the cellular network, the type of data collection system that will be contacted, the type of inputs to process, etc. This is done with a Windows-based program called “MP32®” and a special programming cable as shown here. The MP32® program should be at revision level 6.8.1 or newer. The first cable is no longer available for purchase but will still work for those who still own one.

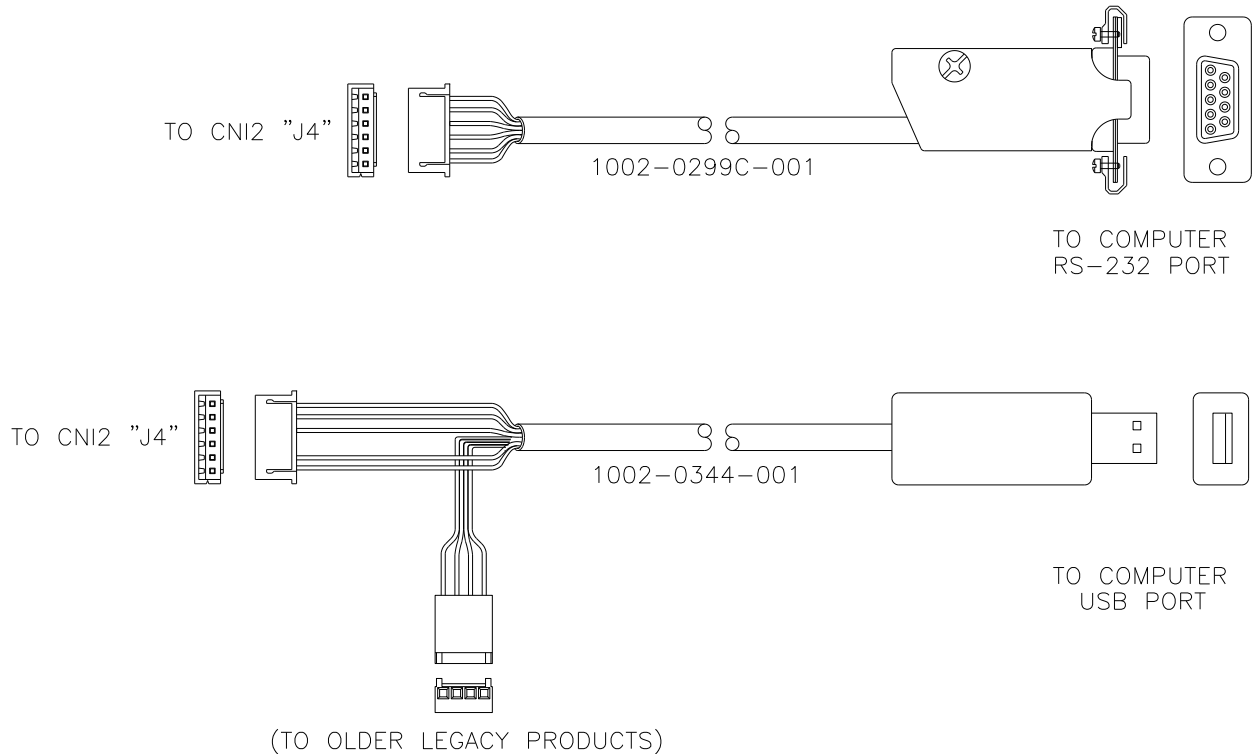

Serial and USB Programming Cables

Starting the MP32[®] configuration Program

When the MP32[®] program is started a login screen will appear. If the “PowerSpring[®]” data collection system is also running on this system then you will need to enter an authorized user name and password that is valid for PowerSpring[®].

Otherwise if PowerSpring[®] is not running on this system then use the default user name and password as is and select *OK*.

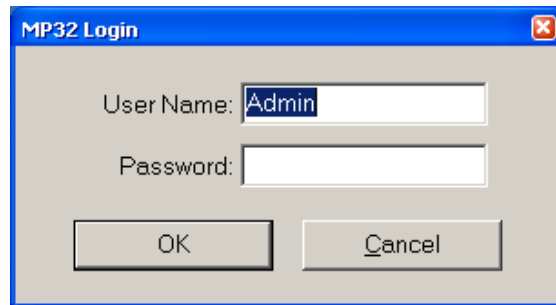

MP32[®] Login Screen

The next screen to appear will be the device selection screen.

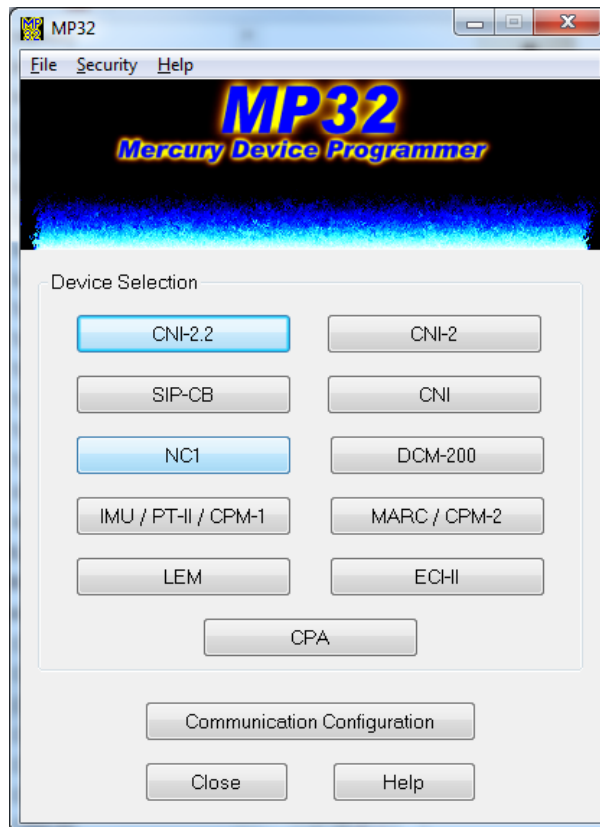

MP32[®] Device Selection Screen

CONFIGURING THE PROGRAMMING PORT

MP32® needs to know which COM port to use with the programming cable. Select the “*Communications Configuration*” button on the device selection screen.

When the USB programming cable is first plugged in, the system should detect it and load the necessary driver software. If you are having problems with this, contact us and we can help. When the installation is complete the system will assign a new COM port to the cable, such as COM5. It may not be immediately apparent what COM number has been assigned to a USB device. To find this out (with the cable plugged in) go to:

Settings → Control Panel → System → Hardware → Device Manager → Ports

You should see your USB cable there and its assigned COM port. Each USB cable has a unique electronic serial number. The computer will remember this number. If one USB cable is unplugged and another one is installed, the system will not reuse the previous COM port number. Rather it will assign a new COM port number to it. For instance, if the previous cable was assigned COM5, then the new cable might become COM6.

If using the older serial programming cable then the COM port is the physical COM port number that the cable is plugged in to, typically COM1 or COM2.

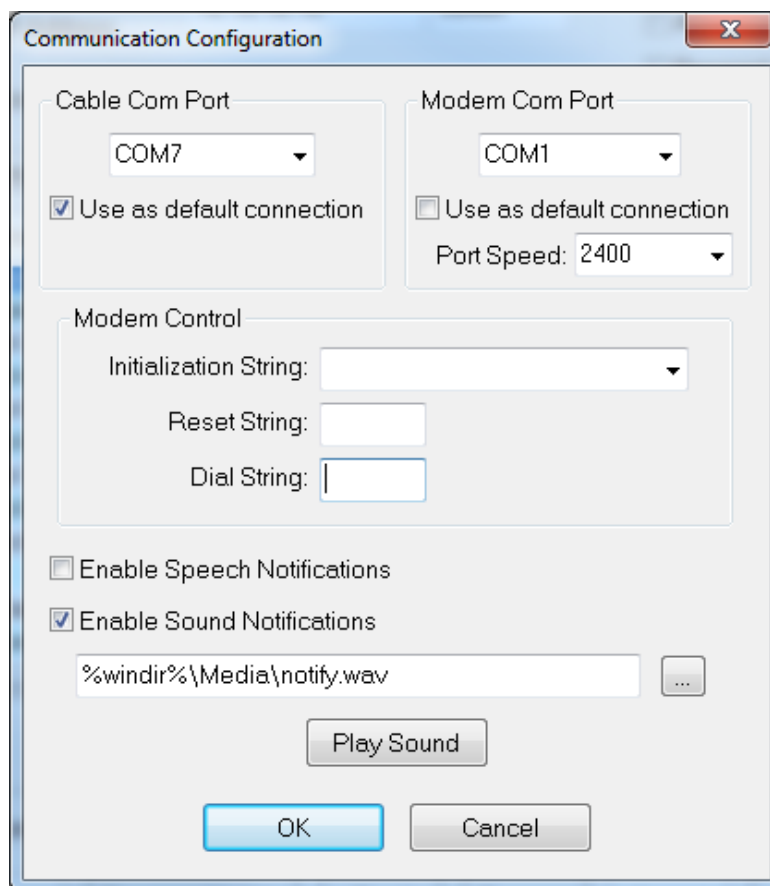

Programming Port Configuration Screen

Check the “Use as default Connection” under the *Cable COM Port* heading, select the appropriate COM port number and then select *OK*.

NOTE
For COM ports greater than COM9 you must precede the COM number by \\.\ such as \\.\COM14

Sound / Speech notifications allow you to add audible notifications for various MP32 functions or error conditions.

Starting the Programming Application

When the device selection screen appears select the **CNI2.2** button for the CNI2e-H or the **CNI2** button for the CNI2e-C.

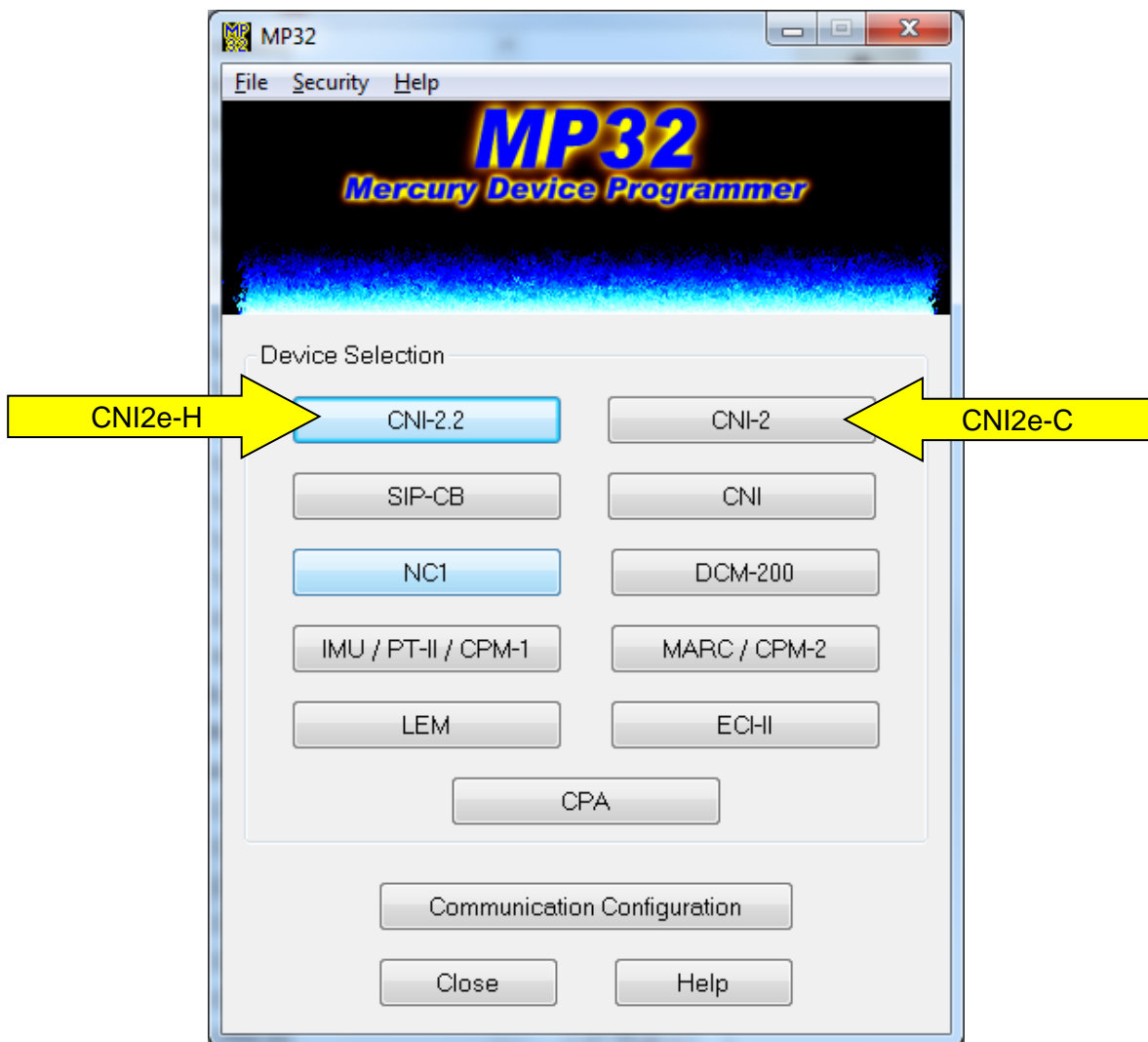

CNI2 Device Selection Screen

The following screen will appear. Some fields are filled in for demonstration purposes and may be different than those you will enter.

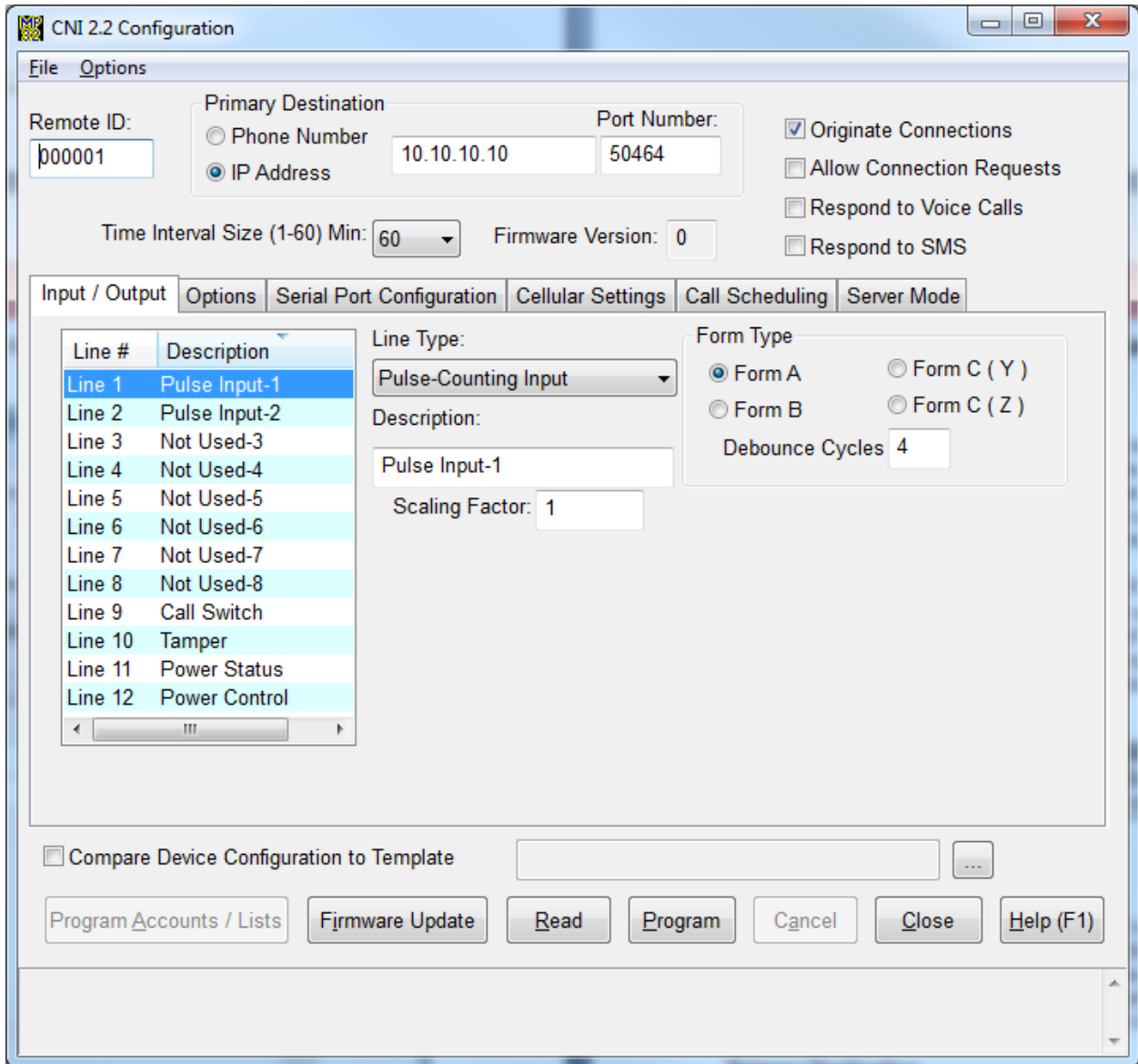

CNI2e Main Configuration Screen

MAIN SCREEN

Saving and Retrieving Configurations

A “configuration” is a set of parameters that will be programmed into the CNI2e. It is also referred to as a “template”. Once you define a configuration it can be saved by using the *FILE* pull-down menu in the upper left-hand corner of the screen. A previously saved configuration can be opened in the same manner. This is useful if many units are to be programmed with similar information, such as all using the same destination IP addresses or cellular information.

To start a programming session either *OPEN* a previously saved template or manually enter all of the parameters. If you would like to work with the configuration that is already stored in the CNI2e you can perform a *READ* operation of the CNI2e with the programming cable installed and the unit powered up. The status of the operation is displayed on the bottom of the screen. The *CANCEL* button will terminate the session in the event there is no response or an error.

IMPORTANT NOTE

Reading the configuration from a CNI2e automatically resets the unit and clears all accumulated data and time of day.

Remote Unit ID (RUID)

As a data logger or InvisiConnect modem, each CNI2e must have a unique six-digit ID number. This is required by the data collection system. Legal values are 000000-FFFFFF (hexadecimal notation). Sequential numbering is not required, nor is it necessary to use any of the hexadecimal digits ‘A, B, C, D, E, or F’. Typically if you do not specify the ID number prior to shipment then the CNI2e is shipped with an RUID that is the last six digits of the serial number located on the front label. If the CNI2e is being used as a transparent modem only, the RUID number does not matter.

Primary Destination

CSD mode is similar to a dial-up connection on a wired phone line. CSD service is no longer offered by most cellular service providers in North America. If the CNI2e is allowed to originate a CSD data call to another modem then it will need the phone number of that modem. Select the “*Phone Number*” button and enter up to 32 numeric digits. As with most cellular phones, it is usually necessary to enter the entire phone number, including area code, even if the call is local. For example in the U.S., a call to 555-1212 within area code 987 may have to be entered as 19875551212.

If the CNI2e is to communicate via the Internet then it will need the IP address and port number of the data collection server or host system. Your computer system’s administrator usually assigns these values. Select the “IP Address” button. Then enter the address of the server expressed in “dotted decimal format”, such as 198.32.67.101. Do not use port numbers below 1024.

The Primary Destination is used for scheduled calls, consumption-related alarms, page call-backs, low battery alarms, etc. Any hardware input that has been programmed as an alarm input can have its own unique destination. This will be discussed shortly.

Originate Calls

Check this box if the CNI2e is allowed to originate CSD or Internet connections. This allows the CNI2e to call in at regularly scheduled times or whenever an alarm condition occurs. When using the Internet for communications the CNI2e acts as a “client”. It can only originate calls to the data collection system, which is considered an internet “server”.

Allow Connection Requests

This setting allows the CNI2e to act as an Internet “server”, allowing it to be contacted via the Internet. When this box is checked the *Server Mode configuration* screen is used to define specific server features.

IMPORTANT NOTE

The *Allow Connection Requests* feature requires the cellular radio to be powered up more frequently. This will have a great impact on battery life. A permanent power source such as solar or AC is recommended if you wish to use this option.

Respond to Voice Calls / Respond to SMS

“Paging” is a mechanism that causes the CNI2e to call back to the Primary Destination on demand. You can page the CNI2e by calling its cellular voice number or by sending it a text message using SMS, or short message service. Your cellular account may not offer voice or SMS service as a default, so you may have to request it.

In addition to paging, if the CNI2e is configured for CSD mode then checking the “*Respond to Voice Calls*” box will allow the CNI2e to answer incoming CSD calls from the central office.

IMPORTANT NOTE

The *Respond to Voice Calls / Respond to SMS* options are NOT recommended for battery-powered operation. These options require the cellular radio to be powered up at all times, which will quickly drain the CNI2e’s batteries. A permanent power source such as solar or AC is recommended if you wish to use these options.

Time Interval Size

As a data logger you can configure the CNI2e to count pulses from up to 6 sources. Pulses are counted over a specific time interval and the total for that period is saved as one record. It then starts the counting process over for the next time interval and this process continues indefinitely. The time interval can be 1, 2, 3, 5, 6, 10, 12, 15, 20, 30 or 60 minutes (anything evenly divisible into 60). A shorter time period allows you to observe small changes with more detail. But it also consumes storage space more quickly, causing the CNI2e to need to communicate with the data collection system more frequently so that older data is not lost. This can have an impact on both battery life and the cost of the cellular service.

The CNI2e has the capacity to save a total of 30,000 records before it starts to overwrite the oldest records. These are divided equally between all active pulse-counting channels. If only one channel is used for pulse-counting then all 30,000 record locations will be used for that channel. If using a 10-minute interval it would take a little over 200 days to reach the end of the memory. If three channels are active then each channel is allocated 1/3 of the memory, or 10,000 records.

If some of the pulse / alarm inputs are not being used for pulse-counting then they should be programmed as alarm inputs even if they are not going to be used for alarms. This will cause the memory to be divided between only those channels that will be counting pulses.

The data collection system (PowerSpring® or MV90®) must also be configured with the same interval size; otherwise the calls from the CNI2e will be rejected. Although the CNI2e can accept up to six channels of pulse information, PowerSpring® or MV90® can only accept four.

Firmware Version

The firmware version number is reported any time the configuration is read from the CNI2e using the programming cable. This value cannot be altered. For instance a value of 18 means V1.8.

Compare Device Configuration to Template

This feature is useful when programming many CNI2e devices with similar information. When the CNI2e's configuration is read it is compared to a configuration file (a "template") of your choice. If there are any differences other than the unit's ID number, they will be displayed. You can manually enter the filename of the template or use the browse button to locate it on your system.

INPUT / OUTPUT CONFIGURATION

The CNI2e has six (6) digital lines that can serve as alarm sensing or pulse-counting inputs, or as outputs. See the previous section called [Digital Signal Inputs & Outputs](#) for more information.

Alarm Input Parameters

An “alarm” is an event such as a switch closing or opening. When configured as a Metretek SIP data logger the CNI2e reports the alarm condition to the data collection system (PowerSpring® or MV90®) using standard descriptions as shown in this table:

Line Designation	Alarm Text Reported by PowerSpring
Line #1	“Alarm-1”
Line #2	“Alarm-2”
Line #3	-
Line #4	-
Line #5	-
Line #6	-
Line #7	-
Line #8	-
Line #9	“Call” or “Mag Switch”
Line #10	“Tamper”
Line #11	“AC-On” and “AC-Off”
Line #12	“KYZ4”

Standard Metretek SIP Alarm Descriptions

Any description can be changed in the data collection system. For instance if Line#10 is used for something other than the TAMPER switch it will still be reported to the data collection system as a TAMPER alarm. But you can change the alarm description at the central office to something like “Pump Failure” or “High Temperature” to more-accurately describe the event.

<p style="text-align: center;">NOTE</p>
--

<p style="text-align: center;">There are no physical connection points for Lines #3 thru #8</p>

An example configuration for the internal “CALL” switch is shown here.

Line #	Description	Line Type:	Form Type
Line 1	Pulse Input-1	Alarm Input	Form A
Line 2	Pulse Input-2		Form B
Line 3	Not Used-3		Form C (Y)
Line 4	Not Used-4		Form C (Z)
Line 5	Not Used-5		Debounce Cycles 4
Line 6	Not Used-6		
Line 7	Not Used-7		
Line 8	Not Used-8		
Line 9	Call Switch		
Line 10	Tamper		
Line 11	Power Status		
Line 12	Power Control		

Enable Server Mode on input going active
 Input going active indicates primary power source has failed
 Immediate call on input going active
 Immediate call on input going inactive
 Default alarm to Primary Destination

Destination: Phone Number IP Address

Port Number: 10.10.10.10 50464

Configuration of an Alarm Input

Select “*Alarm Input*” from the “*Line Type*” pull-down list.

You can give this input a *Description* of 15 characters or less. This is for your records only and is not reported to the data collection system.

If the input is a normally-open switch then select *Form-A*. If the input is a normally-closed switch then select *Form-B*. If you are combining lines together to create a KYZ input, then select *Form-C (Y-normally open)* or *Form-C (Z-normally closed)*. If you select *Form-C* for one line then the next line will automatically be assigned as the other *Form-C* input and will inherit the partner’s settings. Allowed *Form-C* pairs are Lines-1&2, 9&10 and 11&12.

The “*Debounce*” setting, in combination with the “*Sample Rates*” setting on the *OPTIONS* screen determines how long the switch needs to be closed or open before being considered a “real” alarm event. Debouncing and sample rates are discussed in more detail later in this document.

The “*Immediate Call on Input Going Active*” will cause the CNI2e to call immediately into the central office when the alarm event is sensed.

The “*Immediate Call on Input Going Inactive*” will cause the CNI2e to call immediately into the central office when the alarm event ends.

If neither box is checked then the alarm event will be reported on the next scheduled call.

NOTE

Even if the “*immediate call*” boxes are checked, the data collection system (PowerSpring® or MV90®) has the ability to override them.

The “*Input Going Active Indicates Primary Power Source has Failed*” is usually used in systems that contain a primary power source (ac or solar) and also an emergency backup battery. This puts the CNI2e into a low-power conservation mode until the alarm event is over. During this time some features may not be available. For instance if the CNI2e is configured to respond to SMS pages, which requires that the radio be powered up and running all the time, this mode will be temporarily suspended and the radio will be powered down until the primary power has been restored.

By checking the “*Default Alarm to Primary Destination*” box the CNI2e will call into the Primary destination phone number or IP address. Otherwise you can specify a unique destination for each alarm.

“Special Purpose” Input Parameters

An input can be configured to perform a predefined function that does not relate to normal alarm-sensing or pulse-counting. At this time there are two functions:

- 1) Starting and ending “Power Preservation Mode”, which is a way to conserve power when a primary power source has failed. See the section called “[Power Preservation Mode](#)” for details.
- 2) Starting and / or ending what is called “Server Mode”. Server Mode allows the CNI2e to accept connection requests from the central office over the Internet.

In many cases the CNI2e will only enter Server Mode for brief periods throughout the day. One way to make this happen is to configure one of the inputs as a Server Mode control line.

The next screen shot illustrates how Line-12 is used for this purpose. The *Line Type* is chosen to be “*Special Purpose Input*”. The input is configured as a Form-A (normally open) input. When the “*Enable Server Mode on Input Going Active*” box is checked two more selections will appear. One selection will terminate the Server Mode after a user-defined time period (in the *Server Mode* configuration screen). The other selection will terminate the Server Mode when the input returns to the inactive (open) state.

See the section called “[Server Mode](#)” for many more details.

Input / Output | Options | Serial Port Configuration | Cellular Settings | Call Scheduling | Server Mode

Line #	Description
Line 1	Pulse Input-1
Line 2	Pulse Input-2
Line 3	Not Used-3
Line 4	Not Used-4
Line 5	Not Used-5
Line 6	Not Used-6
Line 7	Not Used-7
Line 8	Not Used-8
Line 9	Call Switch
Line 10	Tamper
Line 11	Power Status
Line 12	Server Control

Line Type: Special-Purpose Input

Description: Server Control

Form Type

Form A Form C (Y)

Form B Form C (Z)

Debounce Cycles 4

Enable Server Mode on input going active

Server Mode Options

End Server mode after Server Mode duration expires

End Server Mode on input going inactive

Configuration of a "Special Purpose" Input

Pulse-Counting Input Parameters

Line #	Description
Line 1	Pulse Input-1
Line 2	Pulse Input-2
Line 3	Not Used-3
Line 4	Not Used-4
Line 5	Not Used-5
Line 6	Not Used-6
Line 7	Not Used-7
Line 8	Not Used-8
Line 9	Call Switch
Line 10	Tamper
Line 11	Power Status
Line 12	Server Control

Line Type: Pulse-Counting Input

Description: Pulse Input-1

Scaling Factor: 1

Form Type

Form A Form C (Y)

Form B Form C (Z)

Debounce Cycles: 4

Configuration of a Pulse Counting Input

Select “*Pulse-Counting Input*” from the “*Line Type*” pull-down list.

You can give this input a *Description* of 15 characters or less. This is for your records only and is not reported to the data collection system.

If the input is a normally-open switch then select *Form-A*. If the input is a normally-closed switch then select *Form-B*. If you are combining Lines-5 & 6 together to create a KYZ input, then select *Form-C (Y-normally open)* or *Form-C (Z-normally closed)*. If you select *Form-C* for one line then the next line will automatically be assigned as the other *Form-C* input and will inherit the partner’s settings. Allowed *Form-C* pairs are Lines-1&2, 9&10 and 11&12. Line-5 settings.

The “*Debounce*” setting, in combination with the “*Sample Rates*” setting on the *OPTIONS* screen determines how long the switch needs to be closed or open before being considered a “real” pulse event. Debouncing and sample rates are discussed in more detail later in this document.

The “*Scaling Factor*” is a **multiplier** in the range of 0.01 to 656.35. This affects how the recorded pulse counts are reported to the host system. This affects both the time-tagged interval readings as well as the totalizers (“time-of-call” readings).

NOTE

The Scaling Factor is only used when the CNI2e is configured as a Metretek SIP data logger. When configured as a Mercury Pulse Accumulator or Mini-Max, there are several item Codes that are used to scale the readings. See the Chapter entitled “[Mercury Instruments Emulation](#)” for details.

Example: Assume the most recent interval count is 29 pulses and the total count so far is 10332.

Scaling Factor	Reported Interval Reading	Reported Total
1	29	10332
0.5	14 (see Note-1)	5166
2	58 (see Note-2)	20664
0.1	2 (see Note-1)	1033 (see Note-1)

Examples of Using the Scaling Factor

NOTE-1

When the CNI2e is configured as a SIP data logger the readings can only be reported in integer format. If a scaling factor results in a remainder, **the remainder will be truncated.**

In the example when the original value of 29 is multiplied by a scaling factor of 0.5, the actual result would be 14.5 but the reported value will be 14.

NOTE-2

When the CNI2e is configured as a SIP data logger the interval readings cannot be larger than 65535.

The CNI2e has the capacity to save a total of 30,000 pulse-counting records before it starts to overwrite the oldest records. These are divided equally between all active pulse-counting channels. If only one channel is used for pulse-counting then all 30,000 records will be used for that channel. If three pulse-counting channels are active then each channel is allocated 1/3 of the memory, or 10,000 records.

NOTE

If you do not require pulse-counting on a line then configure it as a Form-A alarm input so that all other pulse-counting inputs have access to as much storage space as possible.

The data collection system (PowerSpring® or MV90®) must know how many pulse-counting channels are activated. The minimum is 1 and the maximum is 4.

When the data collection system receives the pulse records from the CNI2e it expects them to be in a specific order starting with the 1st input and ending with the last. The CNI2e does not have restrictions regarding the order in which you program the pulse-counting lines. You could program Line #1 and Line #2 as alarms and #9 and #10 as pulse-counters. To stay compliant with PowerSpring here is how the records are sent:

The very 1st line that is programmed for pulse counting is considered "Input-1".
The next line that is programmed for pulse counting is considered "Input-2".
The next line that is programmed for pulse counting is considered "Input-3".
The next line that is programmed for pulse counting is considered "Input-4".

Remember that a Form-C pair is treated as only one input.

Here's an example:

Lines #1, 2, 9 and 10 are configured as alarm inputs and Lines #11 and #12 for pulse-counting. Line #11 is presented as "Input-1" to PowerSpring because it's the 1st line programmed for pulse-counting. Line #12 is presented as "Input-2" because it's the 2nd line programmed for pulse-counting.

Here's another example involving a mixture of Form-C and Form-A settings:

Lines #1 and #2 are programmed for pulse-counting, Form-A operation. Lines #11 & #12 are configured for Form-C pulse counting. Line #1 is presented as "Input-1" to PowerSpring because it's the 1st line programmed for pulse-counting. Line #2 is presented as "Input-2" because it's the 2nd line programmed for pulse-counting. Lines #11/#12 are presented as "Input-3" because they are the 3rd set of lines programmed for pulse-counting.

Output Parameters

An output line can be configured three ways. There is more information about using the outputs in the [Technical Information](#) section of this document.

You can give this input a *Description* of 15 characters or less. This is for your records only and is not reported to the data collection system.

Output Under Host Control

PowerSpring® has the ability to control up to 3 output lines. These can be used to activate external equipment such as pumps or audible alarms.

These outputs are controlled using the “*Relay Information*” screen in PowerSpring’s “*Remote Unit Configuration*” program. This is discussed in an upcoming chapter.

Using the “Output-Under-Host-Control” feature, the outputs are not changed until the call has ended and declared a good call.

There are no restrictions on which digital signals can be programmed as outputs. But PowerSpring refers to Relay Numbers-1, 2 and 3. So here is how the CNI2e handles this:

The very 1st line that is programmed as a host-controlled output is considered “Relay-1”.
The next line that is programmed as a host-controlled is considered “Relay-2”.
The next line that is programmed as a host-controlled is considered “Relay-3”.

NOTE

Whenever the CNI2e is powered up or reset, all outputs that have been configured for host control will be in an “off” condition until changed by PowerSpring.

Output Follows Input

When a line is programmed as an alarm or pulse-counting input its state can be replicated on any one of the output lines, within the frequency limits of the CNI2e. This allows other pulse-counting or alarm-sensing equipment to have access to the same information. For instance the CNI2e may be counting pulses and there may be another piece of equipment located nearby that needs to count these pulses too. The CNI2e can be programmed to transmit a replica of the input signal to this other piece of equipment.

To use this feature select the desired output line. Then from the selection list choose the “*Output Follows Input #x*” where “x” is one of the input lines. For instance you may want Input Line #1 to appear on Output Line #12. You would select Line #12 and then program is as “*Output Follows Input #1*”.

There are some timing limitations when using this feature. This will be discussed shortly.

The output can be configured to have the same polarity as the input, or opposite polarity.

If you select “**Active Low**” then the CNI2e’s output will have the same polarity as the input. If using a solid-state relay or transistor, its output may be the opposite of the original input depending on how the device is wired.

If you select “**Active High**” then the CNI2e’s output will have the opposite polarity as the input. If using a solid-state relay or transistor, its output may be the same as the original input depending on how the device is wired.

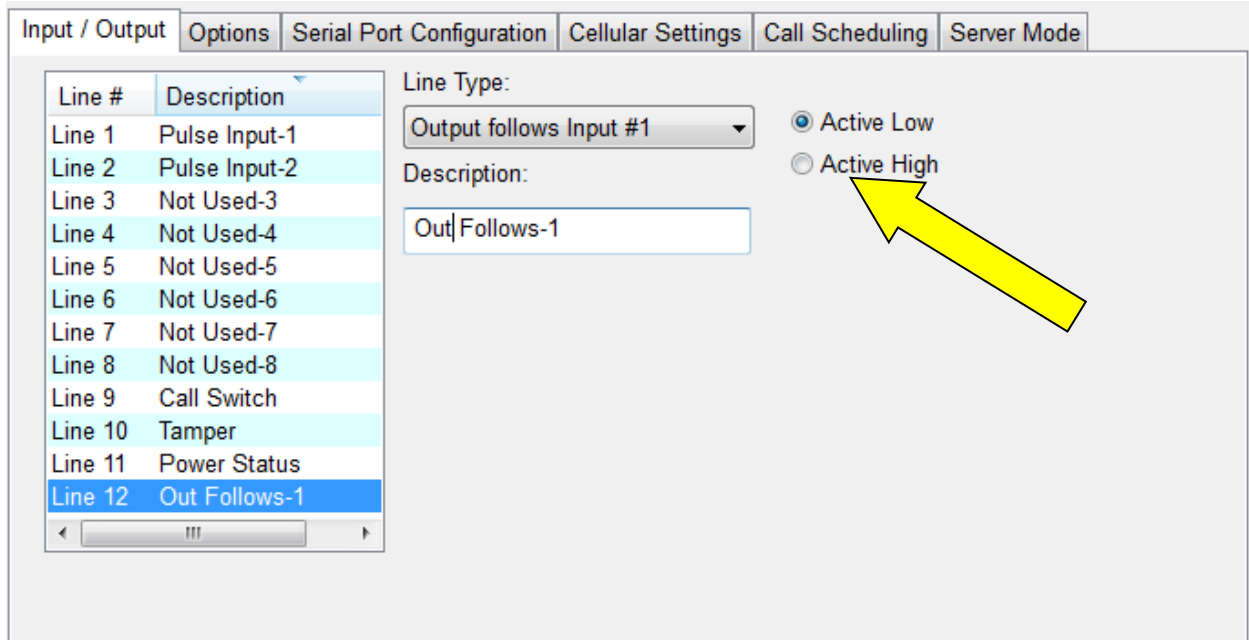

Changing the Polarity of the “Output-Follows-Input” Feature

“Special Purpose” Output

The CNI2e will use a “special purpose” output to control some operation within the unit assembly, such as turning a power supply on or off. At this time the “Special Purpose” output only applies to Line-12. If a unit is shipped with a line programmed as a Special Purpose output, it should not be changed unless you understand the implications.

The screenshot shows a configuration window with several tabs: 'Input / Output', 'Options', 'Serial Port Configuration', 'Cellular Settings', 'Call Scheduling', and 'Server Mode'. The 'Input / Output' tab is active. On the left, there is a table with two columns: 'Line #' and 'Description'. The table lists lines 1 through 12. Line 12, 'Power Control', is selected. To the right of the table, there are configuration options for the selected line. The 'Line Type' dropdown is set to 'Special-Purpose Output'. Below it, the 'Description' text box contains 'Power Control'. To the right of these options are two radio buttons: 'Active Low' (which is selected) and 'Active High'.

Line #	Description
Line 1	Pulse Input-1
Line 2	Pulse Input-2
Line 3	Not Used-3
Line 4	Not Used-4
Line 5	Not Used-5
Line 6	Not Used-6
Line 7	Not Used-7
Line 8	Not Used-8
Line 9	Call Switch
Line 10	Tamper
Line 11	Power Status
Line 12	Power Control

Line Type: Special-Purpose Output

Description: Power Control

Active Low
 Active High

Configuration of a “Special Purpose” Output

As a “Special Purpose Output” Line-12 will go active shortly before the cellular radio is powered up to make a call. It will return to the inactive state shortly after the cellular radio is powered down. The active state (3.3V or to 0V) is defined by the “Active High” or “Active Low” selections on this screen.

OPTIONS SCREEN

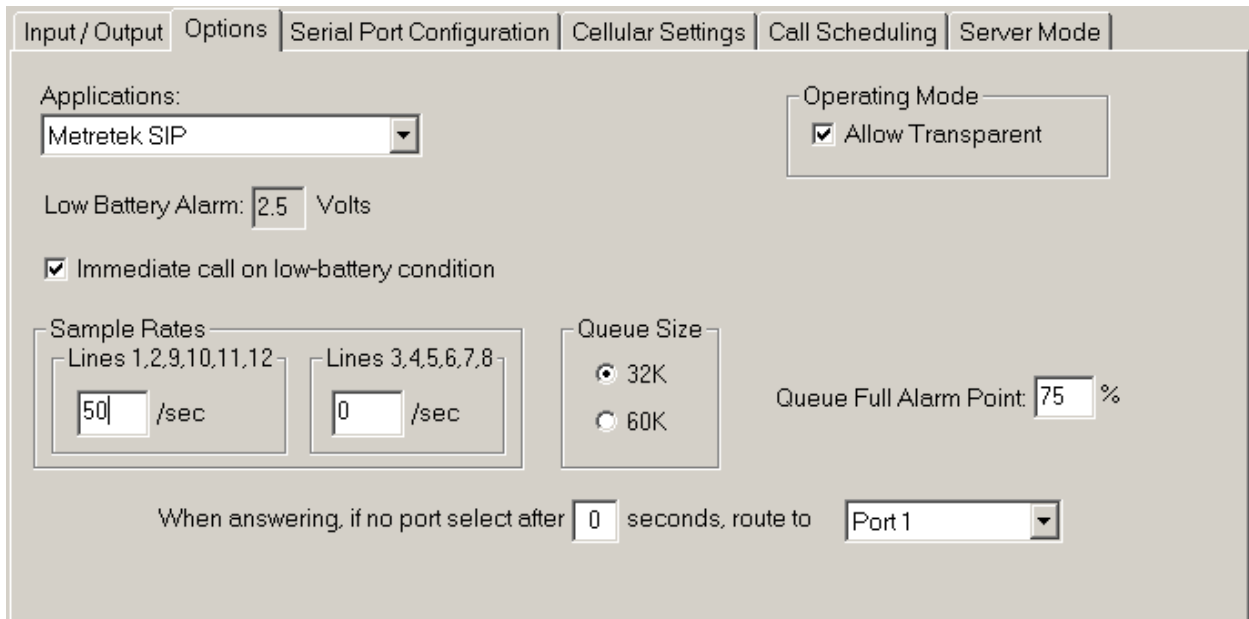

Input / Output Options Serial Port Configuration Cellular Settings Call Scheduling Server Mode

Applications:
Metretek SIP

Operating Mode
 Allow Transparent

Low Battery Alarm: 2.5 Volts

Immediate call on low-battery condition

Sample Rates
Lines 1,2,9,10,11,12: 50 /sec
Lines 3,4,5,6,7,8: 0 /sec

Queue Size
 32K
 60K

Queue Full Alarm Point: 75 %

When answering, if no port select after 0 seconds, route to Port 1

Options Screen

Applications Selection

The CNI2e has several modes of operation. It can serve as a data logger for pulse-counting and alarm sensing applications, a transparent modem to allow the host system to communicate with an external piece of equipment, or as a short-message-service (SMS) modem.

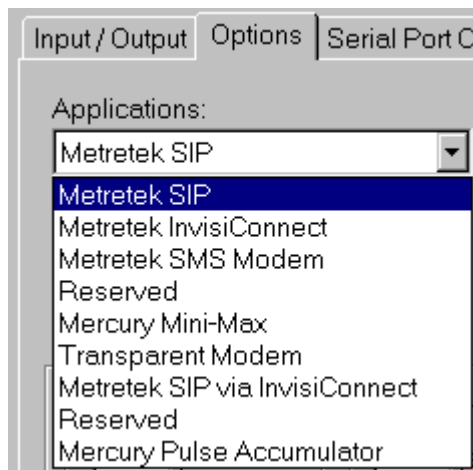

Input / Output Options Serial Port C

Applications:
Metretek SIP
Metretek SIP
Metretek InvisiConnect
Metretek SMS Modem
Reserved
Mercury Mini-Max
Transparent Modem
Metretek SIP via InvisiConnect
Reserved
Mercury Pulse Accumulator

“Applications” Selection Menu

Metretek SIP

When the CNI2e calls into the data collection system (PowerSpring® or MV90®) it will identify itself as a Metretek “SIP” data logger. In this mode the CNI2e serves as a data logger for pulse-counting and alarm sensing applications and uses the legacy Metretek communications protocol. The term “SIP” refers to a Metretek data logger called a Survey Instrument Point.

PowerSpring® supports both CSD and IP (internet) communications with the CNI2e. MV90® only supports CSD connections (see next topic).

Metretek SIP via InvisiConnect

MV90® does not support internet connections with Metretek “SIP” devices. To accomplish this it is necessary to install another software product called “InvisiConnect®”. InvisiConnect® acts as a modem emulator and a transparent “bridge” to the internet. In this case you should select “*Metretek SIP via InvisiConnect*” from the pull-down list.

The CNI2e contacts the InvisiConnect® server first. Data is then transferred between InvisiConnect® and the MV90® system as though the connection was occurring over a wired phone (CSD) connection.

Contact a Honeywell Product Support Specialist for additional details and ordering information for InvisiConnect®.

Metretek InvisiConnect

InvisiConnect® Server is a software application that acts as a modem emulator and a transparent “bridge” to the internet. InvisiConnect® allows older phone line-based applications to be converted to wireless internet communications with little or no changes to the original application software or the field devices.

The CNI2e acts as an alarm-sensing unit as well as a transparent communications link between a device attached to its serial port and the host system that is connected to InvisiConnect® Server. The CNI2e does not support pulse-counting in this mode.

InvisiConnect® allows older phone line-based applications to
Contact a Honeywell Product Support Specialist for additional details about InvisiConnect®.

Mercury MINI-MAX or Mercury Pulse Accumulator

When the CNI2e calls into the data collection system (PowerSpring® or MV90® or AutoSol®) it will identify itself as a Mercury MINI-MAX or Mercury Pulse Accumulator. In this mode the CNI2e serves as a data logger for pulse-counting and alarm sensing applications and uses the legacy Mercury Instruments communications protocol.

There is a separate section of this document called “[Mercury Instrument Emulation](#)” that discusses this mode of operation in detail.

SMS Modem

This mode is primarily used by the InvisiConnect® Server software. In a traditional wired modem setup the central computer can usually contact the remote device directly by dialing its phone number. On the Internet there are “servers” and “clients”. A server is usually a computer system that is always running and always “listening” for connection requests from clients. When you use your personal computer to access a website your PC is the client and the website is the server.

A client cannot be contacted directly via the Internet. In many cases the CNI2e acts as a client only. However the CNI2e can be “paged”. The page then causes the CNI2e to call back immediately to the central office.

One method of paging is by Short Message Service, or SMS. SMS is often used to send short text messages between two cellular phones. In some cases a message can be sent from a computer using a traditional SMTP (email) server.

But there may be obstacles to sending an SMS. First, the computer running the data collection system may not have access to an SMTP server. Or if the computer is using a cellular modem to connect to the Internet it may not be able to send SMS messages without first terminating the Internet connection. Finally, for security reasons, some cellular providers only allow SMS messages to be exchanged between two mobile devices, and not between a mobile device and an SMTP server.

The *SMS Modem* is a special configuration of a CNI2e. Its sole purpose is to allow the central computer to send mobile-to-mobile SMS messages via the cellular network without interfering with existing Internet connections or requiring an email server connection.

Transparent Modem

In this mode the CNI2e serves as a communications device only and does not count pulses or report alarms. It establishes a two-way connection between the central office and any serial device connected to its serial port.

As a transparent modem a call can be triggered by an alarm event (CALL switch, TAMPER switch, etc.). However since it is not calling a known data collection system such as PowerSpring® or MV90® it has no way to report the actual reason for the call.

Allow Transparent Mode

This checkbox only applies when the CNI2e is configured as a Metretek SIP, a Mercury MINI-MAX or Mercury Pulse Accumulator.

At the beginning of a call the CNI2e will attempt to communicate with the data collection system using the Metretek or Mercury protocol. If after a short period of time there is no recognizable response from the system, and if the “*Allow Transparent*” box is checked, the CNI2e will establish a transparent communications link between the device attached to its serial port and the host system.

Here's an example of how this might be used. Let's say the CNI2e is counting pulses from its UMB index and its serial port is connected to a digital camera. The CNI2e will normally call into PowerSpring® or MV90® to report its UMB count information. The data collection system does not know that there is a camera at the site and wouldn't know how to communicate with it anyway.

Now another application program (not PowerSpring® or MV90® or AutoSol®) wants to capture an image of the site where the CNI2e is located. After the CNI2e connects and does not receive a recognizable Metrotek or Mercury response it will establish a connection to the camera. At this point the application program can now communicate directly with the camera and will close the connection when finished.

The time it takes to establish the transparent connection depends on the way the CNI2e is configured. As a Metrotek SIP this could be as short as 5 – 10 seconds. As a Mercury MINI-MAX or Pulse Accumulator this might be as long as 50 seconds or more. There is a separate section of this document called "[Mercury Instrument Emulation](#)" that discusses the reasons for this and ways to shorten the time.

On the *Cellular Settings* configuration screen (to be discussed shortly) is a setting called "Session Timeout". During transparent mode if there is no communications between the host system and the serial device for this period of time, the CNI2e will terminate the connection by itself. This period of time has a direct impact on battery life and should be kept as short as is reasonable for the application.

Also see the next discussion about port selection as this also affects the transparent mode of operation.

When Answering if No Port Select.....

This setting goes back to a legacy application in which the CNI2e's serial port could be expanded to two ports with the use of a small circuit board called the "Serial Port Multiplexer". This device is no longer available due to lack of demand.

However it is very important to set the two parameters as shown below in order for the primary serial port to operate correctly.



Default Port Select Settings

Low Battery Alarm

When the power source gets too low the CNI2e will start logging and reporting low-battery alarms to the data collection system. The voltage level is preset at the factory for most applications. If you check the “*Immediate Call on Low Battery Condition*” box the unit will immediately call in whenever the low-battery condition is detected. If this box is unchecked then the low battery condition will be reported on the next call.

NOTE

Even if the “ <i>immediate call</i> ” box is checked the data collection system (PowerSpring® or MV90®) has the ability to override it.

The CNI2e will record the time of the day that the alarm event occurred and this time will be reported to the central office.

When using the PowerSpring® data collection system you can define a “nuisance limit” that will prevent the CNI2e from calling in continuously to report a low-battery alarm. For instance if the limit is set to 2 then the CNI2e will only call twice to report the alarm between other calls (such as a scheduled call or a call generated by another alarm condition). Once the CNI2e calls in for another reason the “nuisance limit” is reset to 2 and the CNI2e is once again allowed to call in twice to report the low-battery alarm.

The low-battery alarm point can also trigger a special mode called “Power Preservation Mode”. There is a separate [chapter](#) devoted to this mode.

The CNI2e does not react immediately to a low-battery condition. The condition must continue for a certain amount of time to be considered “real”, and must go away for the same amount of time for the event to be considered over.

Current Operating Mode	Power Preservation Mode On	Power Preservation Mode Off
“RUN” Mode (radio powered up)	2 minutes	2 minutes
“STANDBY” Mode (radio powered down)	4 minutes	20 minutes

Once this period of time has elapsed the low-battery event will be logged (and reported if the “*Immediate Call on Low Battery Condition*” box has been checked). The timing period starts over at this point. A new event will be logged (and perhaps reported) once the period of time has elapsed again. This will continue until the low-battery situation has been resolved.

Queue Size

The CNI2e can count electrical pulses from up to six sources although the data collection system (PowerSpring® or MV90®) will only accept up to 4. Pulses are counted over a specific time interval and the total for that period is saved as one record. It then starts the counting process over for the next time interval and this process continues indefinitely. The place where this is stored is called the “queue”.

The time interval can be anything evenly divisible into 60 minutes. A shorter time period allows you to observe small changes with more detail. But it also consumes memory more quickly, causing the CNI2e to need to communicate with the data collection system more frequently so that older data is not lost. This can have an impact on both battery life and the cost of the cellular service.

The CNI2e can save a total of 30,000 records before it starts to overwrite the oldest records. These are divided equally between all active pulse-counting channels. If only one channel is used for pulse-counting then all 30,000 record locations will be used for that channel. If using a 10-minute interval it would take a little over 200 days to reach the end of the memory. If three channels are active then each channel is allocated 1/3 of the memory, or 10,000 records.

Each record consumes 2 bytes of memory. For a queue size of 30,000 records select the “60K” size. For a smaller queue (16,000 records) select the “32K” size. The data collection system (PowerSpring® or MV90®) has the ability to request the entire contents of the queue, so a smaller queue size will result in a shorter call, lower power consumption and lower cellular costs.

Queue Full Alarm

To prevent the loss of accumulated data the CNI2e will place an immediate call to the central office when the storage “queue” reaches a certain point. You can define this as any percentage between 1% and 100%. Default is 75%.

Sample Rates

The CNI2e does not inspect the state of the inputs 100% of the time; otherwise it wouldn't have time to perform any other functions. Rather the CNI2e briefly inspects (“*samples*”) the condition of the lines one or more times each second. You can configure the CNI2e to take as few as one sample per second or as many as 50 samples per second. The 12 possible input/output lines are divided into two groups, each with its own sampling rate. Lines-1, 2, 9, 10, 11 and 12 are one group. Lines-3 thru 8 are in the other group and are not currently implemented in hardware. Set their rate to zero (0) to reduce power consumption.

The sample rate is based on how quickly you expect the inputs to change. Faster sampling rates are used for quickly-changing inputs but results in higher power consumption. Too slow of a sampling rate can lead to errors and missed pulses.

Debouncing and sample rates are discussed in more detail later in this document.

SERIAL PORT CONFIGURATION SCREEN

Besides processing alarms and pulse data the CNI2e can act as a “transparent” modem. This allows the central computer to communicate directly with a device connected to the CNI2e’s RS-232 serial port.

The screenshot shows the 'Serial Port Configuration' screen with the following settings:

- Port Select ID: 123456
- Max BPS: 9600
- Data Bits: 8
- Parity: None
- Stop Bits: 1
- Flow Control: None
- Delay before sending packets: 0 mS
- Listening Port: 40000
- Port Enabled:
- Always send Connect Message:
- Always "RING" port:
- Use non-verbose result codes:
- Enable Blocking:
- Connect on DTR High:
- Disconnect on DTR Low:
- Use Alternate Connect Message:

Port #	Port ID
Port 1	123456
Port 2	000002
Port 3	000003
Port 4	000004
Port 5	000005
Port 6	000006
Port 7	000007
Port 8	000008

Serial Port Configuration Screen

NOTE

The CNI2e was originally designed to have up to eight serial ports. However the hardware required to support this was never developed. Therefore the CNI2 has one and only one serial port, which is Port-1. Do not enable serial ports-2 thru 8.

Port Select ID

Serial Port-1 is automatically assigned the Primary RUID. Its Port Select ID is grayed out and cannot be changed.

Port Enable

If you intend to use Serial Port-1, check the *Port Enabled* box. If you do not intend to use the serial port, turn it off to conserve power.

Max BPS, Data Bits, Parity, Stop Bits

These parameters must match the settings of the device connected to each serial port.

Flow Control

There may be situations in which the device connected to the serial port is sending data at a rate that exceeds the CNI2e's capacity to process it and pass it on to the central computer.

In packet (internet) mode the data from the serial device is assembled into a "packet", then sent on to the central computer. A packet cannot be larger than 1100 bytes and each packet's arrival at the central computer must be verified before another can be sent. Due to latency in the cellular networks and on the Internet each exchange may take several seconds to complete. During this time it may be necessary to stop the serial device from sending any more information. The actual packet size is adjustable using the "Maximum Packet Size" setting in the *Cellular Settings* configuration screen.

Some devices do not support any kind of handshaking and may have large messages to send. This is not usually a problem in CSD mode because each byte is immediately sent to the central computer. In packet mode when the user-defined packet size is reached it is sent to the server. Meanwhile the data that continues to be transmitted by the serial device is stored in memory. After the previous packet has been sent another is collected, packaged and sent. As each packet is delivered to the server there is that much more space is freed up for new data. However, it is possible for the serial device to eventually overrun the memory if the packets are slow to be delivered to the server. This may lead to the loss of data. One possible solution is to reduce the baud rate between the serial device and the CNI. This may give the CNI2e enough time to deliver packets and keep up with new data.

There are several methods commonly used to control the flow of data between serial devices, generally called "handshaking". The selections are *None*, *Hardware*, *Software* or *RS-485 Half Duplex*. Other selections are for other applications and should not be used.

Hardware Handshaking

Hardware handshaking uses additional signals on the hardware interface to stop and start the flow of data from the serial device. On the CNI2e's terminal block is an output signal called DSR. This signal would normally be connected to the "CTS" (clear-to-send) input line on the serial device. Initially the DSR line will be positive. A positive voltage on this line indicates that the serial device may transmit data. When DSR goes negative, the serial device should halt its transmission. When the connection is terminated the DSR line will go negative for a brief moment and then go positive until the next connection.

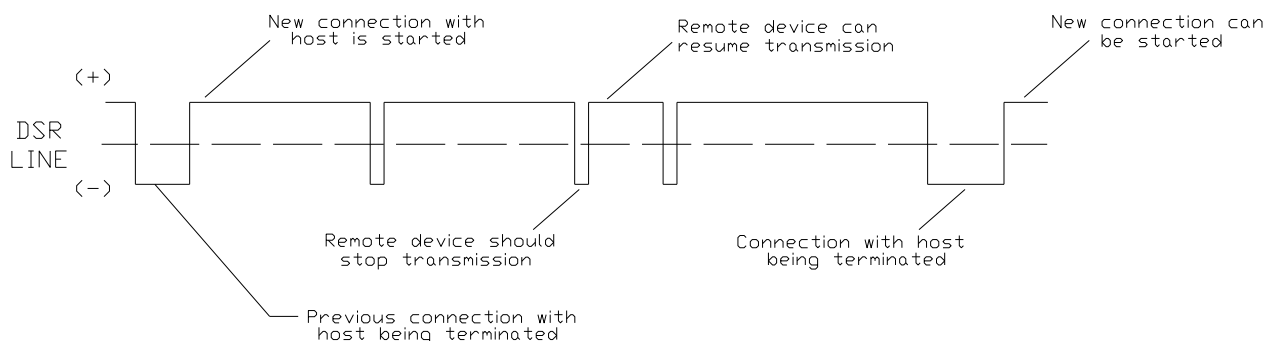

Hardware Flow Control

Software Handshaking

Xon/Xoff handshaking (also called “software handshaking”) uses two ASCII characters to stop and start the flow. The CNI2e will send an “Xoff” (19 decimal or 13 hex) to the serial device to stop the transmission, and an “Xon” (17 decimal or 11 hex) to resume transmission. Once an Xoff character is sent the serial device should halt its transmission. Also the DSR line will remain positive throughout the session. When the connection is terminated the DSR line will go negative for a brief moment and then go positive until the next connection.

No (None) Handshaking

If *NONE* is selected the DSR line will remain positive throughout the session. When the connection is terminated the DSR line will go negative for a brief moment and then go positive until the next connection. In CSD mode each byte of data from the serial device is immediately passed on to the central computer, and vice versa. In this case flow control is generally not needed and “*NONE*” can be selected as the flow control method.

In packet mode if the serial device never sends more than 1100 bytes in one message and must receive a response before sending another message, then the flow control can be set to “*NONE*”.

RS-485 Half Duplex

Select this only if an external RS485 conversion module is being used in half-duplex mode.

Delay before Sending Packets

In packet mode the data from the serial device is assembled into “packets” and sent on to the central computer. The maximum size of the packet is programmable and cannot exceed 1100 bytes. The data from the serial device is sent out whenever it exceeds the maximum packet size.

However some or all messages from the serial device may never exceed the maximum packet size. Therefore the CNI2e must have a way to determine when the serial device’s message is complete and ready to send to the host. Some serial devices may terminate a message with a particular character like a carriage return or line feed. However for other devices these two characters may be meaningful data. Therefore searching for a particular terminating character may not work in all cases.

The CNI2e determines when a message is complete when there have been no characters received from the serial device for a certain period of time. This value can range from 1 to 65535 milliseconds and may have to be determined experimentally. A value that is too low may cause a message to be sent in several packets. Also, each packet contains the device’s message along with some overhead information used for routing and error checking. Breaking a larger message down into several packets means more overhead and could affect the cost of the cellular service. Remember, the cost of packet service is usually based on the number of bytes exchanged in a month.

Choosing a value that is too high may cause the application program running on the central computer to abort or retry too often because it did not receive a response within an acceptable period of time.

Start with a value of 50 ms and fine-tune it from there.

Listening Port

The CNI2e can act as an internet server and accept connection requests from other clients. This is discussed in detail in the section of this document called [Server Mode](#).

In order to connect to the CNI2e the client must know the CNI2e's IP address and port number. The CNI2e has its own "listening" port number which appears on the Server Mode Screen. Each serial port has a listening port number as well. Starting with firmware version V1.4 this allows the client to establish a connection to a device attached to the serial port rather than to the CNI2e itself. See [Connections to a Specific Serial Port](#) for more details about this.

For instance if the CNI2e is configured as a data logger, and also allowed to be a transparent modem, the listening port that appears on the Server Mode Screen will address the data logger, whereas the listening port that appears on the Serial Ports Screen will address the instrument that is connected to the CNI2e's serial port.

<p>NOTE Do not use a Listening Port number of 0 (zero).</p>

Always Send CONNECT Message

The serial device connected to the CNI2e can request a call or answer an incoming call by issuing specific "AT" commands such as "ATD" (dial) or "ATA" (answer). When the connection with the central computer has been established the CNI2e will send a "CONNECT" message to the serial device to let it know that the connection has been established.

The CNI2e can also place a call on its own in response to an alarm condition or some other event. In these situations the CNI2e would not normally send a "CONNECT" message to the serial device. However some devices may require a "CONNECT" message before allowing further communications. By checking the *Always Send Connect Message* box the CNI2e will always send a "CONNECT" message every time it connects with the central computer, regardless of who originated the call.

Always "RING" Port

In some applications the serial device connected to the CNI2e may have been programmed to automatically answer incoming calls. After the call is answered and a connection is established with the central computer a "CONNECT" message is usually sent to the serial device.

In other applications the serial device might control when incoming calls will be answered. The CNI2e will send a number of "RING" messages to the serial device and wait for the serial device to respond with an answer ("ATA") command. If this mode is required, check the *Always "RING" Port* checkbox. The CNI2e will send up to three "RING" messages to the remote device. If an "ATA" is received the CNI2e will respond with a "CONNECT" message. If no response is

received the CNI2e will send a “CONNECT” message only if the *Always Send Connect Message* box has been checked.

Use Non-verbose Result Codes

For AT-compatible modems a “verbose” message is usually a readable text string such as “CONNECT” or “RING”. A “terse”, “numeric”, or “non-verbose” message typically consists of one or two numeric digits, such as “2”. The CNI2e defaults to verbose messages, but the remote device can change this by issuing an “ATV” or “ATV0” command. However some devices may simply expect non-verbose messages and will not issue any additional commands to make this happen. In this case check the *Use Non-verbose Result Codes* box.

Enable Blocking

This is used solely for InvisiConnect® applications and is not currently supported.

Use Alternate CONNECT Message

Usually the serial device requires some sort of notification when a connection has been established with the central computer. Often this message will be “CONNECT xxxx”, where “xxxx” indicates the baud rate, such as “CONNECT 9600”. The CNI2e defaults to this format, but the serial device can change this to a simple “CONNECT” message by issuing an “ATX” command. However some serial devices may simply expect a simple “CONNECT” message and will not issue any additional commands to make this happen. In this case check the *Edit CONNECT Message* box.

You must specify the exact message in the *Connect Message* window. This includes non-readable (control) characters. Non-verbose responses are often one to two ASCII numbers followed by a carriage return character. Verbose messages are normally preceded and followed by a carriage return and line feed combination. Use the “Enter” key on your keyboard to insert a carriage return and line feed combination. To insert a single line feed character press and hold the ALT key while on the keyboard’s numeric keypad enter the digits 0 1 0. Then release the ALT key. To insert a single carriage return character press and hold the ALT key while on the keyboard’s numeric keypad enter the digits 0 1 3. Then release the ALT key. In either case you will not actually see the characters in the window, but you may see the cursor move to the next line.

Connect on DTR High

Some serial devices may indicate a desire to place a call by simply activating a control line. On the CNI2e’s serial port is an input line called DTR. If the DTR input line on the communications terminal block goes positive, the CNI2e will wait 10 seconds for an “ATD” (dial) or “ATA” (answer) command from the device. If a command is received the CNI2e will start the call process. Otherwise a call will be placed after 10 seconds and the CNI2e will behave according to the *Always Send Connect Message* setting. If enabled a “CONNECT” message will be sent to the serial device once the connection with the central computer has been established. The call will end with a “NO CARRIER” message. If the connection cannot be established a “NO CARRIER” message is returned.

NOTE

When the CNI2e is in low-power “sleep” mode it can only detect that the DTR line is active if one of the hardware configuration jumpers has been set to the proper position. See the [ELECTRICAL ASSEMBLIES](#) section for the location of these jumpers.

Disconnect on DTR Low

Some serial devices may indicate a desire to terminate a call by simply deactivating a control line. On the CNI2e’s serial port is an input line called DTR. If the DTR input line on the communications terminal block is positive when the call starts, and then goes negative while the call is in progress, the CNI2e will terminate the call.

CELLULAR SETTINGS SCREEN

“SIP” Versus “MIP”

If the CNI2e will be communicating over the Internet there are two protocols that can be used. The original protocol used in the early days of dial-up and wireless Internet service is called Simple Internet Protocol, or “SIP”. Some wireless carriers no longer support SIP.

The more-recent Mobile Internet Protocol, or “MIP”, solves the problems of losing an internet connection as you travel from cell to cell, or if your call is passed on to a roaming partner.

The CNI2e will likely be in a fixed location and therefore doesn't require MIP. However there are now certain cellular providers that have dropped support for SIP in favor of MIP. You have the ability to choose which protocol to use. Check with your service provider if in doubt.

NOTE

If you have a choice between using SIP and MIP, SIP is generally faster, resulting in shorter calls.
--

“Dynamic” Versus “Static” IP Addresses

Each time the CNI2e requests an internet connection from the cellular provider it is assigned an IP (Internet Protocol) Address. You can request a “Static” IP address for each CNI2e. This means that the CNI2e is assigned the same address with each connection. You may have to pay more to have a Static IP address.

There are two forms of static IP addresses. A “public” static IP address takes its address from a global pool. No other device on the global internet will have that same address. There are very few carriers that can assign a “public” static IP address. A “private” static IP address requires you and the carrier to establish what is known as a virtual private network, or “VPN”. In this case each CNI2e can be assigned a unique address, but this could be the same address as another device in the world. However since the CNI2e is operating on a VPN, the address is never broadcast to the public internet, only to the private network.

If you do not request a Static IP address then the CNI2e will likely be assigned a new address each time it connects. This is known as a “Dynamic” IP address. This address is only valid for the current connection and will likely be assigned to another device after the current connection is terminated.

If you intend to allow the CNI2e to act as a Server then it must have a Static IP address. Server Mode is discussed later in this document. In order for some other machine to contact the CNI2e that machine must know the IP address of the CNI2e. This is why it is important for the IP address to remain constant.

Otherwise if the CNI2e will only call in to a server such as PowerSpring® and InvisiConnect® then a Static IP address is not a requirement.

CDMA Service (CNI2e-C only)

CDMA is an abbreviation for **C**ode **D**ivision **M**ultiple **A**ccess communications. CDMA technology was originally developed for military applications but was eventually commercialized. This communications standard is widely used in North America and in some parts of Asia and South America.

Rather than dividing calls into time slots like GSM, CDMA allows all users to transmit at the same time. Each call is accompanied by a unique digital code that allows it to be differentiated from the rest. As an analogy suppose you are in a crowded room and many conversations are taking place at the same time. Your brain is able to distinguish the conversation you are having with your friend because it is able to focus on your friend's voice characteristics. As the room grows more crowded each person must talk louder and the size of the conversation "zone" grows smaller. You may have to move closer to your friend to keep the conversation going. Thus the number of conversations is limited by the overall interference and noise in the room.

A cellular account must be activated with a cellular service provider prior to placing a CNI2e-C into service. The service provider may ask the device type, which must be specified as the "CNI2e-C". In North America CDMA/1X service is supported by Aeris or Verizon on the 850 and 1900 MHz bands. This is considered "2G" technology

CDMA Packet (Internet) Service

Single carrier, radio transmission technology (1X or 1XRTT) packet service may have to be added to a standard voice plan, or may be a stand-alone service.

Packet service packages are generally priced by the number of bytes to be transferred rather than by the minute. Typically the smallest available package will be 1 megabyte (1 Mb) per month. The amount of data that the CNI2e-C will produce depends upon what sort of data is requested from the CNI2e-C. The amount of information exchanged on each call may range from several hundred bytes to 10's of thousands of bytes. It may be necessary to test the system for several months and then adjust the cellular account for the best cost based on your needs.

The CNI2e-C requires full Internet access because the data collection software could be running on any server located anywhere in the world. Full access is usually assigned to customers who will be connecting a cellular modem to a personal computer.

If you are allowed to use Simple Internet Protocol (SIP) one parameter that will be needed is the packet service connection command. In most cases the command will be **ATD#777** but you may want to check with your service provider.

CDMA Circuit Switched Data (CSD) Service

The service provider must support asynchronous circuit-switched data (CSD) exchange at the baud rate of the central computer's modem. Sometimes this capability may be included as part of a standard voice package or it may be an add-on feature at extra cost.

One consideration when ordering service is the frequency of calls to and from the CNI2e-C.

Each service provider offers different packages that may include a fixed number of minutes per month for a fixed price. However, when this number is exceeded, the cost per each additional minute can be very high. There are also variations in the way “minutes” are measured. For example, a call lasting 1 minute 10 seconds may be considered to be a 2-minute call by some providers. It might be possible to purchase less expensive packages that have additional “weekend” or “evening” minutes, and then schedule the CNI2e to call in at those times. Some plans may offer the 1st minute free. This might be advantageous for short calls.

Another consideration when ordering service is the location of the CNI2e with respect to the service provider’s network. It is best to describe where the units will be located and where they will be calling, otherwise you could be charged “roaming” or long-distance fees. Some providers offer free long distance or no roaming charges as part of their basic plans.

The final consideration is the direction of the calls. If the CNI2e is to originate calls, then the service must support “mobile-originate” service. If the unit is to receive calls, then “mobile-terminate” service is required.

The service provider may need the following information:

- Type of cellular service desired, which is *circuit-switched data (CSD)*.
- The device type, which must be specified as the “CNI2e -C”.
- Data rate. This rate must match the speed of central computer’s modem.
- Mobile-originate and/or mobile-terminate service.
- Number of minutes per month.
- Location of the CNI2e-C and the location of central computer (to determine if “roaming” or long distance charges apply).
- The service provider will need to know the “MEID” number printed on the radio or on the [cover](#) of the CNI2e-C.

Over-the-Air-Activation (OTAA)

CDMA technology does not support the use of a SIM memory card (Subscriber Identity Module) to hold and transport account information. Therefore the account information must be downloaded into the cellular radio’s own memory. For Verizon this is accomplished by dialing a special phone number to request “over-the-air-activation” (OTAA). The activation phone number is specific to the service provider and must be programmed into the CNI2e-C.

The OTAA process does two things. After the first successful OTAA call a new phone number is programmed into the phone. This is the number that can be used to page the unit via a phone or data call, or via an SMS message. It also starts the account billing process. Second, a “preferred roaming list” (PRL) is downloaded into the phone. This instructs the radio which service provider(s) to search for and connect to.

Over-the-air activation is attempted whenever the unit is reset. Another call will be attempted if the first one fails. After two unsuccessful attempts the CNI2e-C will go into an idle mode and will attempt another OTAA call every hour until one is successful. Until then the unit will not be able to call in to the data collection system.

After the first successful call an OTAA call is then performed every 7 days. The reason for this is that cellular service providers often make arrangements with other providers to carry calls in

areas where their own equipment and towers do not exist. These agreements allow the call to be forwarded at no additional charge. The preferred roaming list says that it is acceptable to connect with these carriers. However at some point your service provider may install new equipment in these areas and the contract with the partner may be terminated. In this new situation roaming fees will be added to each call if the radio is allowed to connect to the other carriers. This is why it is important to periodically update the PRL.

For service providers that do not support “over-the-air-activation” the radios must be preprogrammed at our factory prior to shipment.

Go to the Cellular Settings screen and select “CDMA” as the *Service Type*.

The screenshot shows the 'Cellular Settings' screen with the following configuration:

- Service Type: CDMA (indicated by a yellow arrow)
- CDMA OTA Programming: [Blank]
- Packet Service Connection Command: [Blank]
- Session Timeout (sec): 30
- Ping Interval (sec): 0
- Source port starting number: 50000
- Source port ending number: 50010
- PAP: User Name: 1234567890@VZW3G.C, Password: [Redacted], Confirm Password: [Redacted]
- PIN Number: [Blank]
- Maximum packet size: 1000
- Destination Modem Baud Rate: AUTO BAUD

CDMA Cellular Configuration Screen

OTAA Programming Number

For Verizon customers, after purchasing CDMA service the radio must dial a special phone number to be activated and to have account information downloaded into the phone’s memory. This phone number is specific to the carrier and must be entered into the “*OTAA Programming Number*”.

For Verizon the number is usually *228,,,,,1; (*228 followed by five (5) commas, then a “1” followed by a semicolon).

NOTE
If your CDMA service provider does not support OTAA programming then leave this field blank. At the time of this writing only Verizon supports this.

Packet Service Connection Command

This command is needed to request a Simple Internet Protocol (SIP) packet connection. For most CDMA service providers the phrase **ATD#777** will work, and this is the default setting for the CNI2e-C in CDMA mode. If you are having problems connecting, this could be the problem. Contact your service provider for more information.

NOTE

Leaving the Packet Service Connection Command field blank automatically selects If Mobile Internet Protocol (MIP).

Session Timeout

If there is no communications between the CNI2e-C and the data collection system for this many seconds then the CNI2e-C will terminate the connection. Recommended value is 30 seconds. If you have the CNI2e-C configured as a Mercury Mini-Max or Pulse Accumulator, and are using MasterLink® software, you might want to make this value longer to allow you more time to work with the CNI2e.

Ping Interval

Due to the limited bandwidth of cellular networks the carrier might temporarily take resources away from an idle device in order to service another. When the idle device needs service again the carrier will reallocate resources back to it. This may cause some delays.

The Ping Interval is only used for InvisiConnect applications and only when it is set to something other than 0 seconds. The CNI2e-C will send a short 4-byte message to the host system every xxx seconds. This may help to keep resources allocated to the CNI2e-C, this avoiding the delays involved with resource shuffling. It is recommended to start with a value of 20 seconds and adjust through a process of experimentation.

Source Port Starting / Ending Numbers

This only applies to packet (Internet) connections.

PowerSpring® and InvisiConnect® act as an Internet servers on your computer and thus must be allowed access to the outside world. Most corporate computer systems use firewall technology to prevent unauthorized and potentially damaging access from outside sources. To minimize potential invasion PowerSpring® or InvisiConnect® and the CNI2e-C exchange private information using the 64-bit data encryption standard (DES64). If this exchange fails, the connection is terminated by both sides.

When the CNI2e-C calls in it assigns itself what is known as a “*source port*” number. To further enhance security the CNI2e-C can be assigned only one or a specific range of source port numbers that the firewall will allow through.

Valid source port numbers are 40000 – 65535. The CNI2e-C will use a new number with each call. For example for a range of 50000 – 50010, the first call will use 50000, the 2nd call 50001, and so on. When 50010 has been used the next port number will roll back to 50000. You can also lock it down to one and only one port number buy using the same number for both the starting and ending port number.

PAP User Name and Password

As an added security measure some cellular service providers require Password Authentication Protocol, or PAP, to gain access to their Internet service. The radio must present a user name and a password that was assigned when the cellular service was purchased. The user name or password can be any combination of printable characters, including spaces, such as “Bob Smith” or “1234”. The total number of characters for both the user name and password cannot exceed 48 characters. Often the cellular provider has a specific format for the username and password, so you will need to obtain that information from them.

The password is hidden on this screen for added security. You must enter the password twice to verify that it was entered correctly.

NOTE

If PAP is not required then both the user name and password fields must be blank, otherwise the connection may be refused.

Maximum Packet Size

The setting has no affect in CSD mode. In packet (IP) mode the data from the serial device is assembled into “packets” and sent on to the central computer. The maximum packet size is 1100 bytes. Depending upon cellular network congestion and the quality of the radio connection, it may help to reduce the packet size. The larger the packet, the more chance there is for errors. Several smaller packets may have a better chance of arriving intact than a single large one. As each packet arrives at the central computer, it is checked for errors. If a packet arrives with errors, the computer will request retransmissions until it arrives intact or until a maximum number of retries have occurred. This can introduce significant delays and may increase the cost of the cellular service. Remember, the cost of packet service is based on the number of bytes exchanged in a month. Excessive retries may cause your maximum plan limit to be exceeded.

If you notice excessive retries, or if the connection between the CNI2e-C and the central computer terminates early or often, this may be the cause.

Destination Baud Rate

When using Circuit Switch Data (CSD) service you must select the baud rate of the destination modem. This may require some experimentation. Start with "Auto Baud". If this does not work then select a specific rate.

Some service providers do not support rates above 14,400 bps. GSM (2G) service providers usually don't offer anything above 9600 / V32.

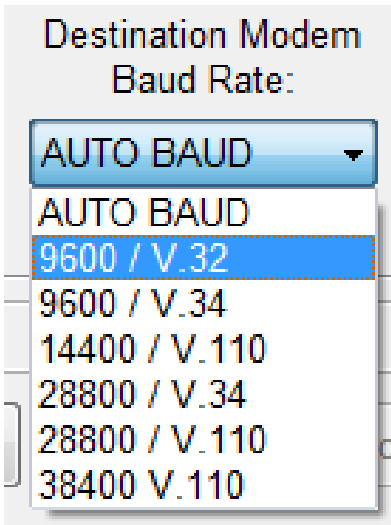

Destination Modem Baud Rate for CSD Service

Notes about using Aeris Cellular Service

Aeris Communications Inc. (or simply Aeris) has special requirements that affect the behavior of the CNI2e-C.

- After a reset, the CNI2e-C will wait from 0 to 255 seconds before powering up the radio. The CNI2e-C uses the last two digits of the RUID to calculate a delay time between 0 and 255 seconds (0x00 to 0xFF hex). During the delay period the green LED will flash twice, turn off for 1 second, flash twice again and continue this pattern until it is time to power up the radio.
- After a reset, and once every 7 days thereafter, once the radio is powered up there will be a delay of 120 seconds prior to making a call. This allows time for the Aeris network to make changes to such things as the preferred roaming list. During the delay period both the green and red LEDs will turn on for 1 second, turn off for 1 second and continue this pattern until it is time to place the call.
- Each time a call is about to be made there will be a 5-second delay after the radio is powered up. This allows time for the Aeris network to send special instructions to the CNI2e-C, one of which prevents the CNI2e-C from ever using the radio again.

GSM (2G) SERVICE (CNI2E-H ONLY)

GSM is an abbreviation for **G**lobal **S**ystem for **M**obile communications. This communications standard is widely used throughout Europe, Africa, Asia and parts of North and South America. Messages are digitized into packets and sent in brief bursts during allocated time slots using a variation of TDMA (Time Division Multiple Access) techniques. Up to 8 cellular phones can thus share the same frequency band, which in turn permits the system to support more users with existing equipment. Efficient utilization of spectrum is an important consideration for service providers since there is only a limited bandwidth space that has been allocated to cellular phone service.

Most GSM systems throughout the world operate on either the 900 MHz or 1800 MHz communications bands. In North America most GSM systems operate on the 850 and 1900 MHz bands and are supported by AT&T, T-Mobile, Rogers in Canada.

2G service on the AT&T network will end on December 31, 2016. However AT&T began turning off 2G service in select areas in North America throughout 2015. This may affect T-Mobile users too because there some of T-Mobile's 2G traffic "roams" on the AT&T network.

WCDMA (3G) SERVICE (CNI2E-H ONLY)

WCDMA is an abbreviation for **W**ideband **C**ode **D**ivision **M**ultiple **A**ccess. It is not an evolution of GSM technology but meant to be a replacement for GSM technology. Most WCDMA radios also support GSM technology as a fall-back mechanism in the event that WCDMA is not available.

Most WCDMA systems throughout the world operate on the 900 MHz, 1800 MHz or 2100 MHz communications bands. In North America most WCDMA systems operate on the 850, 1900 and 2100 MHz bands and are supported by AT&T, and Rogers, Telus and Bell Mobility in Canada.

Portions of T-Mobile's WCDMA network uses the AWS (1700 MHz) band. The CNI2e-H does not support T-Mobile's AWS band.

GSM and HSPA Packet (Internet) Service

General packet radio service (GPRS) is the protocol used on most GSM networks. High Speed Packet Access (HSPA) is the protocol used on most WCDMA networks.

GPRS and HSPA packages are generally priced by the number of bytes to be transferred rather than by the minute. Typically the smallest available package will be 1 megabyte (1 Mb) per month. The amount of data that the CNI2e-H will produce depends upon what sort of data is requested from it. The amount of information exchanged on each call may range from several hundred bytes to 10's of thousands of bytes. It may be necessary to test the system for several months and then adjust the cellular account for the best cost based on your needs.

In order to connect to the Internet, the cellular service provider has its own computer equipment called a "gateway" server, aptly named, as it is their gateway to the Internet. The server will have an "APN" (access point name), usually in the form of a domain name such as

“internetaccess.providername.com” or something as simply as “proxy”. Contact your service provider for this information. This APN will be needed when configuring the CNI2e-H.

Service providers may have several different gateways to choose from, depending upon the type of service required. “Web phones” (cellular phones that support Internet access) are generally assigned to a gateway that only connects to WAP services (wireless application protocol). The CNI2e-H requires full Internet access because the data collection software could be running on any server located anywhere in the world. Full access gateways are usually assigned to customers who will be connecting a cellular modem to a personal computer.

If you are allowed to use Simple Internet Protocol (SIP) another parameter that will be needed is the packet service connection command. In most cases the command will be **ATD*99#** but you may want to check with your service provider.

A cellular account must be activated with a cellular service provider prior to placing a CNI2e-H into service. The service provider may ask the device type, which must be specified as the “CNI2e-H”.

GSM and HSPA Circuit Switched Data (CSD) Service

For CSD service the GSM (2G) service provider must support asynchronous circuit-switched data (CSD) exchange at 9600 baud. CSD Service on WCDMA (3G) networks supports 9600 up to 38,400 baud. Sometimes this capability may be included as part of a standard voice package or it may be an add-on feature at extra cost.

One consideration when ordering service is the frequency of calls to and from the CNI2e-H. Each service provider offers different packages that may include a fixed number of minutes per month for a fixed price. However, when this number is exceeded, the cost per each additional minute can be very high. There are also variations in the way “minutes” are measured. For example, a call lasting 1 minute 10 seconds may be considered to be a 2-minute call by some providers. It might be possible to purchase less expensive packages that have additional “weekend” or “evening” minutes, and then schedule the CNI2e-H to call in at those times. Some plans may offer the 1st minute free. This might be advantageous for short calls.



Another consideration when ordering service is the location of the CNI2e-H with respect to the service provider’s network. It is best to describe where the units will be located and where they will be calling, otherwise you could be charged “roaming” or long-distance fees. Some providers offer free long distance or no roaming charges as part of their basic plans.

The final consideration is the direction of the calls. If the CNI2e-H is to originate calls, then the service must support “mobile-originate” service. If the unit is to receive calls, then “mobile-terminate” service is required.

The service provider will need the following information:

- Type of cellular service desired, which is *circuit-switched data (CSD)*.
- The device type, which must be specified as the “CNI2e-H”.
- Data mode is to support 9600-baud operation. This rate must match the speed of central computer’s modem.
- Mobile-originate and/or mobile-terminate service.
- Number of minutes per month.
- Location of the CNI2e-H and the location of central computer (to determine if “roaming” or long distance charges apply).
- The service provider will need to know the “IMEI” number printed on the radio or on the [cover](#) of the CNI2e-H.

Installation of the SIM Card

 **WARNING** 

Make sure the CNI2e-H is powered down before inserting or removing the SIM card or damage may result to the SIM card.

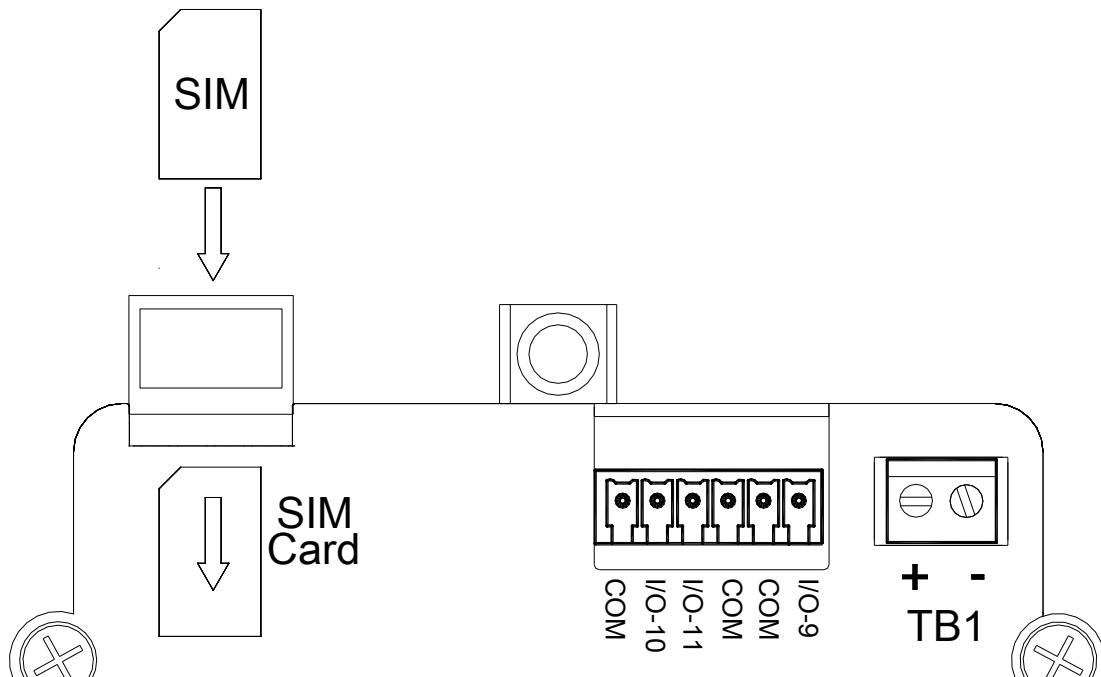

Installation of the SIM Card

Service Type

Go to the Cellular Settings screen and select one of the following as the *Service Type*.

- **“GSM Only”** locks down the service to GSM (2G) only on the 850, 900, 1800 and 1900 MHz bands.
- **“HSPA Only”** locks down the service to HSPA (3G) only on the 850, 900, 1800, 1900 and 2100 MHz bands.
- **“HSPA & GSM”** supports both GSM (2G) and HSPA (3G) services on all five bands. When searching for service the radio will start with WCDMA (HSPA) first and then fall back to GSM if no WCDMA service can be found.

The screenshot shows the Cellular Settings screen with the following configuration:

- Service Type:** HSPA AND GSM (indicated by a yellow arrow)
- Access Point Name:** [Empty text field]
- Packet Service Connection Command:** ATD*99#
- Session Timeout (sec):** 30
- Ping Interval (sec):** 0
- Source port starting number:** 50000
- Source port ending number:** 50010
- Destination Modem Baud Rate:** AUTO BAUD
- PAP:**
 - User Name: [Empty text field]
 - Password: [Empty text field]
 - Confirm Password: [Empty text field]
- PIN Number:** [Empty text field]
- Maximum packet size:** 1000

Cellular Settings Screen

NOTE

The safest Service Type Setting is **“HSPA Only”** or **“HSPA & GSM”**. It may take the CNI2e-H longer to find service but in some areas of North America the GSM networks are being turned off and replaced with WCDMA (HSPA) networks.

Should a CNI2e-H be deployed with **“GSM Only”** it may operate for a while and then go silent if the network drops 2G coverage.

Access Point Name

If the CNI2e-H will be making an Internet connection the cellular service provider will need to provide an Internet APN (access point name). In order to connect to the Internet, the provider has its own computer equipment called a “gateway” server. The server will usually have an APN in the form of a domain name, such as “myserviceprovider.com” or a generic name such as “proxy”. Contact your service provider for this information.

Packet Service Connection Command

This command is needed to request a Simple Internet Protocol (SIP) packet connection. For most GSM / HSPA cellular service providers the phrase **ATD*99#** will work and this is the default setting for the CNI2e-H. If you are having problems connecting, this could be the problem. Contact your service provider for more information.

NOTE

Leaving the Packet Service Connection Command field **blank** automatically selects **If Mobile Internet Protocol (MIP)**.

NOTE

If the CNI2e-H is to be used as a **Server**, it can only be contacted using **Simple Internet Protocol (SIP)**.

At the present time the radio module does not support Server Mode using Mobile Internet Protocol (MIP).

Session Timeout

If there is no communications between the CNI2e-H and the data collection system for this many seconds then the CNI2e-H will terminate the connection. Recommended value is 30 seconds. If you have the CNI2e-H configured as a Mercury Mini-Max or Pulse Accumulator, and are using MasterLink® software, you might want to make this value longer to allow you more time to work with the CNI2e.

Ping Interval

Due to the limited bandwidth of cellular networks the carrier might temporarily take resources away from an idle device in order to service another. When the idle device needs service again the carrier will reallocate resources back to it. This may cause some delays.

The Ping Interval is only used for InvisiConnect applications and only when it is set to something other than 0 seconds. The CNI2e-H will send a short 4-byte message to the host system every xxx seconds. This may help to keep resources allocated to the CNI2e-H, this avoiding the delays involved with resource shuffling. It is recommended to start with a value of 20 seconds and adjust through a process of experimentation.

Source Port Starting / Ending Numbers

This only applies to packet (Internet) connections.

PowerSpring® and InvisiConnect® act as an Internet servers on your computer and thus must be allowed access to the outside world. Most corporate computer systems use firewall technology to prevent unauthorized and potentially damaging access from outside sources. To minimize potential invasion PowerSpring® or InvisiConnect® and the CNI2e exchange private information using the 64-bit data encryption standard. If this exchange fails, the connection is terminated by both sides.

When the CNI2e calls in it assigns itself what is known as a “*source port*” number. To further enhance security the CNI2e can be assigned only one or a specific range of source port numbers that the firewall will allow through.

Valid source port numbers are 40000 – 65535. The CNI2e will use a new number with each call. For example for a range of 50000 – 50010, the first call will use 50000, the 2nd call 50001, and so on. When 50010 has been used the next port number will roll back to 50000. You can also lock it down to one and only one port number buy using the same number for both the starting and ending port number.

NOTE

Source Port Starting and Ending numbers can only be used with Simple Internet Protocol (SIP).

**At the present time the radio module does not support specific Source Port numbers using Mobile Internet Protocol (MIP).
If using MIP, the radio will choose a random Source Port number with each call.**

PAP User Name and Password

As an added security measure some cellular service providers require Password Authentication Protocol, or PAP, to gain access to their Internet service. The radio must present a user name and a password that was assigned when the cellular service was purchased. The user name or password can be any combination of printable characters, including spaces, such as “Bob Smith” or “1234”. The total number of characters for both the user name and password cannot exceed 48 characters. Often the cellular provider has a specific format for the username and password, so you will need to obtain that information from them.

The password is hidden on this screen for added security. You must enter the password twice to verify that it was entered correctly.

NOTE

If PAP is not required then both the user name and password fields must be blank, otherwise the connection may be refused.

PIN Number

GSM/WCDMA cellular radios require a memory card called a SIM card (Subscriber Identity Module). This is issued when the cellular service is purchased. A SIM holds information about the account so that certain services are made available to the customer such as Internet access. A SIM card can be moved to a different phone or radio, and the account information moves with it. Though convenient, this may encourage someone to steal the SIM card, insert it into his or her own cellular phone and make hundreds of hours of calls that will be billed to you or your company.

A personal identification number (PIN) is an extra security measure to prevent unauthorized use of a SIM card. The PIN number can range from 1 to 8 numeric digits long and can be assigned by the cellular service provider when the card is activated.

<p style="text-align: center;">NOTE</p>
--

<p style="text-align: center;">If a PIN number is not required then the PIN number field <u>must</u> be blank.</p>

Maximum Packet Size

The setting has no affect in CSD mode. In packet (IP) mode the data from the serial device is assembled into “packets” and sent on to the central computer. The maximum packet size is 1100 bytes. Depending upon cellular network congestion and the quality of the radio connection, it may help to reduce the packet size. The larger the packet, the more chance there is for errors. Several smaller packets may have a better chance of arriving intact than a single large one. As each packet arrives at the central computer, it is checked for errors. If a packet arrives with errors, the computer will request retransmissions until it arrives intact or until a maximum number of retries have occurred. This can introduce significant delays and may increase the cost of the cellular service. Remember, the cost of packet service is based on the number of bytes exchanged in a month. Excessive retries may cause your maximum plan limit to be exceeded.

If you notice excessive retries, or if the connection between the CNI2e-H and the central computer terminates early or often, this may be the cause.

Destination Baud Rate

When using Circuit Switch Data (CSD) service you must select the baud rate of the destination modem. This may require some experimentation. Start with “Auto Baud”. If this does not work then select a specific rate.

Some service providers do not support rates above 14,400 bps. GSM (2G) service providers usually don't offer anything above 9600 / V32.

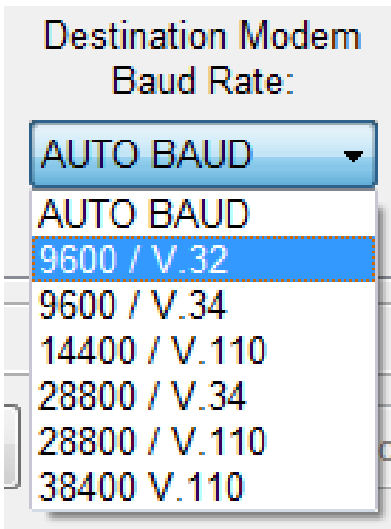

Destination Modem Baud Rate for CSD Service

CALL SCHEDULING SCREEN

Input / Output | Options | Serial Port Configuration | Cellular Settings | Call Scheduling

Call Retry Strategy

Primary Call Retry Count (0-255)

Every(1-255) Minutes

Secondary Retry Interval Every (0-255): Hours

Try Alternate Destination after failed call attempt

Alternate Destination

Phone Number Port Number:

IP Address

Enable Repetitive Call Schedule

Repetitive Call Rate (Min):

Call Scheduling Screen

Call Retry Strategy

If the CNI2e attempts a call and the call is unsuccessful for any reason, it can try the call again at a later time. It can also be told to retry the call to a different computer or not retry the call at all.

If many CNI2es are installed and programmed to call the same system around the same time then it is likely that a few of the calls may fail due to network congestion, or the data collection system may not be configured to accept that many calls at once. To reduce the chance of retries it is best to spread the call schedule out among all of the units.

An overly-aggressive retry strategy will reduce battery life.

Primary Call Retry Count

This is the number of times that the CNI2e will try to repeat a call at the *Primary Call Retry Interval* rate, which is a value between 1 and 255 minutes. Once a call is successful the retry strategy is cancelled. But if the *Primary Retry Count* is exhausted then subsequent calls will be attempted at the *Secondary Call Retry Interval*.

If the *Primary Retry Count* value is specified as 0 then no primary retry attempts are made and the CNI2e will go immediately to the *Secondary interval*.

Primary Call Retry Interval

This is the number of minutes to wait between each Primary retry attempt. The range is from 1 to 255 minutes.

Secondary Call Retry Interval

After the *Primary Call Retry Count* has expired, or if it was set to 0 to begin with, the *Secondary Call Retry Interval* defines the number of hours between each additional attempt, up to 255 maximum. There is no limit to the number of times the CNI2e will attempt a call at this rate. Once a call is successful the retry strategy is cancelled.

If the secondary interval is specified as 0 then no further attempts will be made to retry the call.

To completely disable the retry strategy, set both the *Primary Retry Count* and the *Secondary Retry Interval* to zero (0).

Disabling the retry strategy is not recommended for most applications. Each time the CNI2e contacts PowerSpring® or MV90® it is given a new time to call back. If a call fails and the unit is not allowed to retry the call, it will never receive a new call-back time and therefore will not have a reason to call back again unless an alarm situation forces a new call.

If you do disable the retry strategy you may want to consider using the *Repetitive Call Schedule* feature. With this enabled the unit will have another reason to call in at a later time.

Try Alternate Destination

The *Try Alternate Destination* feature applies only to a CNI2e configured as a “Metretek SIP”, “Metretek SIP via InvisiConnect”, “Mercury MINI-MAX” or “Mercury Pulse Accumulator”.

If the CNI2e attempts a call and the call is unsuccessful for any reason, it can immediately retry the call to a different destination. If this 2nd call also fails then the CNI2e will follow the normal retry strategy described earlier. Each new retry will start with a call to the primary destination followed by a call to the alternate destination if the call to the primary destination fails.

This feature is useful when there are several data collection systems sharing the same database and the primary system is overwhelmed with other calls or is down for maintenance or some other reason.

Even if the retry strategy is disabled, if the *Try Alternate Destination* is checked, the CNI2e will still try one call to the alternate destination if the call to the primary destination fails.

Enable Repetitive Call Schedule

In some applications you might want the CNI2e to call in at regular intervals. Check the box and enter the time period in minutes. This schedule will be followed as soon as the unit is reset or reprogrammed. For instance if the unit is to call in every 24 hours enter a value of 1440 minutes.

Special Retry Strategy for Unique InvisiConnect Applications

In this application it is desired to keep the CNI2e field devices connected to one of two InvisiConnect servers on a full time basis. Should one of those servers become unavailable due to maintenance or network problems, the field devices will attempt to connect to the other server and stay connected to that server until it becomes unavailable.

This strategy will be enabled only if:

- a) The CNI2e is configured as an InvisiConnect device,
- b) The CNI2e's "Try Alternate Destination" feature is turned on,
- c) The Primary Retry Interval is set to 0 or 1 minutes. 0 minutes will cause the CNI2e to retry the connection immediately when the previous connection fails, otherwise it will wait 1 minute before the next connection is attempted.

In the following discussion, the "Primary" server is that defined as the "Primary Destination" and the "Alternate" server is that defined as the "Alternate Destination".

The screenshot displays the 'CNI2 Configuration' window with the following settings:

- Remote ID:** 000001
- Primary Destination:**
 - Phone Number: (unselected)
 - IP Address: 10.34.192.45 (selected)
 - Port Number: 50464
- Time Interval Size (1-60) Min:** 60
- Firmware Version:** 0
- Response to Voice Calls:** (checked)
- Response to SMS:** (unchecked)

The **Call Retry Strategy** section includes:

- Primary Call Retry Count (0-255):** 3
- Every(1-255) Minutes:** 5
- Secondary Retry Interval Every (0-255) Hours:** 2
- Try Alternate Destination after failed call attempt:** (checked)
- Alternate Destination:**
 - Phone Number: (unselected)
 - IP Address: 19.23.123.67 (selected)
 - Port Number: 50464
- Enable Repetitive Call Schedule:** (unchecked)
- Repetitive Call Rate (Min):** 60

At the bottom, there are buttons for 'Program Accounts / Lists', 'Firmware Update', 'Read', 'Program', 'Cancel', 'Close', and 'Help (F1)'. Two yellow arrows point to the Primary and Alternate destination fields, labeled 'PRIMARY' and 'ALTERNATE' respectively.

The special retry strategy will do this:

- a) If the CNI2e is able to connect to the Primary server, but loses the connection at some point, it will retry the next call to the Primary server again.
- b) Only after the CNI2e is unable to connect to the Primary server three times in a row will it attempt to connect to the Alternate server.
- c) After connecting to the Alternate server, if it loses the connection, it will retry the next call to the Alternate server again.
- d) Only after the CNI2e is unable to connect to the Alternate server three times in a row will it attempt to connect to the Primary server.
- e) If neither server is available then the CNI2e will alternately try each one three times (3 to Primary, 3 to Alternate, back to Primary, etc.). This will continue on forever or until one of the servers is contacted.

NOTE

In this mode the Primary Retry Count is ignored and the CNI2e will never enter Secondary Retry.

SERVER MODE

“Servers” and “Clients”

On the Internet there are “servers” and “clients”. A server is a computer system that is always running and always “listening” for connection requests from clients. When you use your personal computer to access a website your PC is the client and the website’s computer is the server. A client cannot be contacted directly via the Internet.

For security and power-related reasons, the CNI2e usually acts as a client. If the CNI2e is configured as a data logger then the data collection system (such as PowerSpring® or MV90®) is the server.

There may be times when it is desired to contact the CNI2e rather than waiting for it to call in. There are several methods that can be used to “page” the CNI2e. Paging is discussed in various other sections of this document. A “page” can be in the form of an SMS (text) message or the reception of a voice call. In either case the CNI2e will immediately call back to a server and is still acting as a client. The downside to this method is that the CNI2e’s radio must remain powered up at all times to receive the page, and this mode requires a full-time power source rather than batteries.

Another method is to allow the CNI2e can act as a server and accept connection requests from other clients. This still requires the radio to be powered up but the CNI2e can be scheduled to enter this mode for short periods of time to maximize battery life. If a full-time power source is used then the CNI2e can remain in Server Mode for as long as needed.

NOTE

If the CNI2e-H is to be used as a Server, it can only be contacted using Simple Internet Protocol (SIP). At the present time the radio module does not support Server Mode using Mobile Internet Protocol (MIP).

The CNI2e-C can use either SIP or MIP for Server operations.

Server Mode Requirements

Each time the CNI2e requests an internet connection from the cellular provider it is assigned an IP (Internet Protocol) Address. There are two types of IP Addresses; “static” and “dynamic”. Dynamic addresses are assigned from a pool of addresses and are only valid for the duration of a connection. The dynamic address assigned to the CNI2e for one session will likely be different for the next.

In order for another client to contact the CNI2e that client must know the IP address of the CNI2e. So it is important for the CNI2e’s IP address to remain constant. **If you wish to use Server Mode then you must request a “Static” IP address for the CNI2e when setting up the cellular service.** This means that the CNI2e is assigned the same address with each connection and no other device will have that same address. You may have to pay more to have a Static IP address.

Server Mode Security

Allowing any client to connect to the CNI2e has its risks, just as it would with your corporate or private servers. To provide some level of security there are several security features:

- a) The CNI2e must be assigned a “port number”. When the client requests a connection to the CNI2e it must specify the CNI2e’s static IP address and the port number in order for the connection to be allowed.
- b) When the client connects to the CNI2e the CNI2e will know the client’s IP address. You can create a list of up to ten IP addresses, or range of IP addresses, that are allowed to connect to the CNI2e. This is called a “Friends List”.

Server Mode Start / End Options

Generally the use of Server Mode requires a robust power source. To accommodate battery power sources we’ve provided several ways to start and end Server Mode to maximize battery life, as follows:

- a) Server Mode can be scheduled to start and end at specific times during the day and on specific days of the week. The client system can then be configured to contact the CNI2e during those times.
- b) Server Mode can be started when an external signal goes active and ended when that signal goes inactive.
- c) Server Mode can be started when an external signal goes active and ended after a user-defined period of time.
- d) Server Mode can be started by receiving a special ATD command from a device connected to the CNI2e’s serial port and ended after a user-defined period of time.
- e) Server Mode can be ended after the 1st successful connection with a client.

Server Mode LED Indicators

Here is the LED sequence from the time the CNI2e starts a Server session to the time it is ready for a connection request from a client. The **green** LED is mostly used to indicate the status of the radio and the network whereas the **red** LED indicates the progress of the connection.

1. If waking up from low-power “sleep” mode the **green** LED will start flashing once per second.
2. The radio is powered up and initialized for communications. If this is successful the **green** LED’s flash rate will double.

-
3. When adequate signal is detected and the radio registers with the network the **green** LED's flash rate will double again if the signal strength is less than 3 bars or will triple for signal strength of 3 bars or more.
 4. The unit will start a connection sequence. While the **green** LED continues to flash the **red** LED will begin flashing once per second.
 5. When the unit has established a data connection with the network the **red** LED's flash rate will double.
 6. When the unit has gained access to the internet the **red** LED's flash rate will double again. At this point the **red** LED will flash for ½ second and be off for ½ second, and this will repeat as long as the CNI2e is waiting for a connection request.
 7. When the unit establishes a connection with the client both LEDs will light solidly but at half intensity. The **red** LED's intensity will increase and decrease (flicker) during the time that the CNI2e is communicating with the client. If there is a device connected to the CNI2e's serial port then the **green** LED's intensity will increase and decrease (flicker) during the time that device is transmitting or receiving data from the CNI2e.
 8. Once the call has completed both LEDs will return to flashing rapidly.
 9. The **red** LED's flash rate will reduce as the data and network connections are terminated.
 10. The **red** LED turns off at the end of the termination sequence.
 11. If the CNI2e is to remain in Server mode the sequence will start over from Step-4.

Configuring the CNI2e for Server Mode

NOTE

If the CNI2e has been configured to emulate a Mercury Pulse Accumulator or Mini-Max, there is additional information you should know about Server Mode. See the section entitled "[Server Mode \("Call-Out"\) Item Codes](#)" for further information.

Allow Connection Requests

The *Allow Connection Requests* checkbox appears in the upper right-hand corner of the main screen. This box must be checked to allow the CNI2e to establish a Server session of any type.

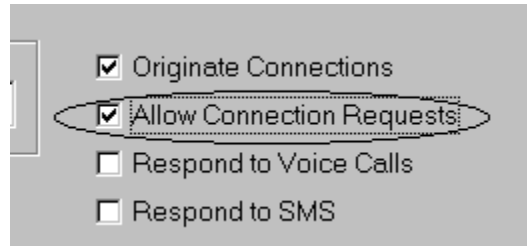

Server Mode Enable Checkboxes

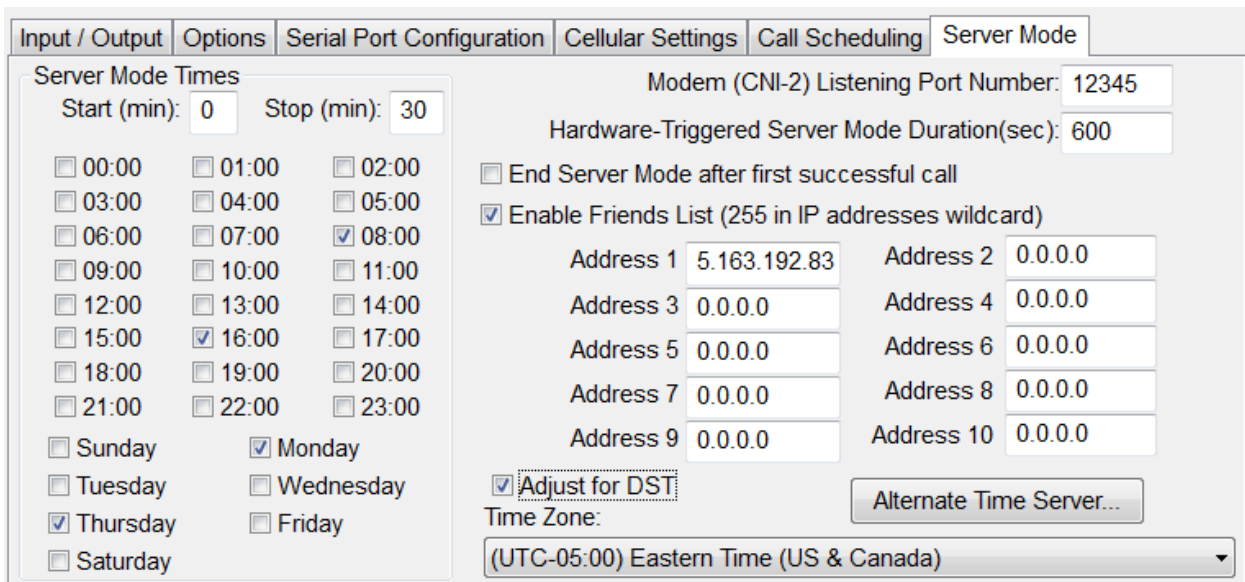
A screenshot of the 'Server Mode' configuration screen. It features several tabs: 'Input / Output', 'Options', 'Serial Port Configuration', 'Cellular Settings', 'Call Scheduling', and 'Server Mode'. The 'Server Mode' tab is active. On the left, 'Server Mode Times' includes a grid of time slots from 00:00 to 23:00, with '16:00' selected, and a list of days of the week with 'Monday' and 'Thursday' selected. On the right, 'Modem (CNI-2) Listening Port Number' is 12345, and 'Hardware-Triggered Server Mode Duration(sec)' is 600. Below these are checkboxes for 'End Server Mode after first successful call' (unchecked) and 'Enable Friends List (255 in IP addresses wildcard)' (checked). A list of ten IP addresses follows, with 'Address 1' set to '5.163.192.83' and others to '0.0.0.0'. At the bottom, 'Adjust for DST' is checked, and the 'Time Zone' is '(UTC-05:00) Eastern Time (US & Canada)'. An 'Alternate Time Server...' button is also present.

Server Mode Screen

Modem (CNI2e) Listening Port Number

When the client requests a connection to the CNI2e it must specify the CNI2e's static IP address and a port number in order for the connection to be allowed. The port number can be any number in the range of 1 to 65535. You can also address the serial port, and this will be discussed in a moment.

NOTE
Do not use a Listening Port number of 0 (zero).

Friends List

When a client connects to the CNI2e the CNI2e will know the client's IP address. You can create a list of up to ten IP addresses, or range of IP addresses, that are allowed to connect to the CNI2e. This is called a "Friends List" and is an added security measure.

If you do not check the *Enable Friends List* box then any client will be allowed to connect to the CNI2e.

Otherwise enter the full IP addresses of those clients that are allowed to connect. This must be in standard dotted-decimal format, such as 54.124.2.98. The maximum value for any number (or "subnet") is 254. If you use 255 for any subnet, this allows any value in the range of 0 – 255 for that subnet.

Example #1: 54.124.19.98 will only allow one address to connect to the CNI2e.

Example #2: 54.124.**255**.98 will allow any address within the range of 54.124.**0**.98 to 54.124.**255**.98 to connect to the CNI2e.

Example #3: **255.255.255.255** will allow any client to connect to the CNI2e and basically defeats the purpose of having a "Friends List".

Unused addresses should be left as 0.0.0.0.

Hardware-Triggered Server Mode

Any hardware input not being used for alarm-sensing or pulse-counting can be used to start and stop a Server session.

This is accomplished using the Input / Output screen. In the following example we are going to use Input Line-11. As with any other input line you can define if the signal is normally open (Form-A) or normally closed (Form-B). If you use Form-C then you will not be able to use Line-12 for any other purpose because Form-C requires the use of two consecutive lines.

You can also define a "*Debounce Count*". The "*Debounce Count*" in conjunction with the "*Sample Rate*" (on the *Options* screen) determines how long the line must be active or inactive before the Server session will start and/or end.

See other sections of this document for complete details about *Form Type* and *Debounce Counts*.

Line #	Description
Line 1	Pulse Input-1
Line 2	Pulse Input-2
Line 3	Not Used-3
Line 4	Not Used-4
Line 5	Not Used-5
Line 6	Not Used-6
Line 7	Not Used-7
Line 8	Not Used-8
Line 9	Call Switch
Line 10	Tamper
Line 11	Server Mode
Line 12	Power Control

Input / Output | Options | Serial Port Configuration | Cellular Settings | Call Scheduling | **Server Mode**

Line Type:

Description:

Form Type: Form A Form C (Y)
 Form B Form C (Z)

Debounce Cycles:

Enable Server Mode on input going active

Server Mode Options:

End Server mode after Server Mode duration expires
 End Server Mode on input going inactive

Using a Hardware Input Line to Start and Stop a Server Session

First, select “*Special Purpose Input*” for the *Line Type*. You can enter a short (15-character) description for this line. In this example we used “Server Mode”.

Next, check the “*Enable Server Mode on Input Going Active*” checkbox. You will then have two ways to terminate the session:

End Server Mode On Input Going Inactive

A Server session starts after the input line has gone active and will end when the input line returns to an inactive (off) state.

End Server Mode After Server Mode Duration Expires

A Server session starts after the input line has gone active and will end after a period of time defined by you (but see the note below).

To define this time go back to the *Server Mode* screen. In the “*Hardware Triggered Server Mode Duration*” box enter the number of seconds that a Server session should last after the input line goes active. A valid range is 1 to 65536 seconds (about 18 hours maximum). In the example below we’ve entered 300 seconds (5 minutes).

Configuration | Cellular Settings | Call Scheduling | **Server Mode**

Modem (CNI-2) Listening Port Number:

Hardware-Triggered Server Mode Duration(sec):

Server Mode Duration Setting

NOTE

If the input line is still active when the Server Mode Duration time expires, the current Server session will be extended until the line returns to an inactive state.

ATD Command-Triggered Server Mode

Any device connected to the CNI2e's serial port can start a Server session by issuing one of the following commands:

ATD0.0.0.0/xxxxx
ATDT0.0.0.0/xxxxx
ATDP0.0.0.0/xxxxx

Where "xxxxx" is a number between 0 and 65535 and has the following meaning:

- If "xxxxx" is 0 (zero) then the current Server session will end after a period of time defined by you. To define this time go back to the *Server Mode* screen. In the "*Hardware Triggered Server Mode Duration*" box enter the number of seconds that a Server session should last after the ATD command is received. A valid range is 1 to 65536 seconds (about 18 hours maximum).
- If "xxxxx" is anything other than 0 then this will be the number of seconds that the Server session will last. A valid range is 1 to 65536 seconds (about 18 hours maximum).

When acting as a Server the CNI2e will not respond with a CONNECT message until a remote client requests a connection. This could be many minutes or even hours after the ATD command has been issued. Your serial device should be prepared for this.

Starting with V1.6 of the CNI2e firmware, the following enhancements were made to make command-triggered Server mode more useful:

- When the Server session is started (a listening socket opened, waiting for a connection request from a remote client) the CNI2e will return an "OK" message to the serial port.
- When a connection request made by a remote client is accepted the CNI2e will return a "CONNECT" message to the serial port.
- When the Server session ends the CNI2e will return a "NO CARRIER" message to the serial port.
- When the Server session is started (a listening socket opened, waiting for a connection request from a remote client) the session can be terminated by the reception of a hang up command (ATH or ATH0) from the serial port.

Scheduled Server Mode

The left side of the Server Mode screen is used to define a schedule for Server sessions to start and end. You can select any day of the week, any hour of the day and the start / end minutes within those hours.

Example:

We would like the CNI2e to wake up and go into Server mode every Monday and Thursday between two specific time periods; 8:10 AM – 8:30 AM, and 4:10 PM – 4:30 PM (16:10 – 16:30). See the next figure for the required settings.

Server Mode Times

Start (min): 10 Stop (min): 30

<input type="checkbox"/> 00:00	<input type="checkbox"/> 01:00	<input type="checkbox"/> 02:00
<input type="checkbox"/> 03:00	<input type="checkbox"/> 04:00	<input type="checkbox"/> 05:00
<input type="checkbox"/> 06:00	<input type="checkbox"/> 07:00	<input checked="" type="checkbox"/> 08:00
<input type="checkbox"/> 09:00	<input type="checkbox"/> 10:00	<input type="checkbox"/> 11:00
<input type="checkbox"/> 12:00	<input type="checkbox"/> 13:00	<input type="checkbox"/> 14:00
<input type="checkbox"/> 15:00	<input checked="" type="checkbox"/> 16:00	<input type="checkbox"/> 17:00
<input type="checkbox"/> 18:00	<input type="checkbox"/> 19:00	<input type="checkbox"/> 20:00
<input type="checkbox"/> 21:00	<input type="checkbox"/> 22:00	<input type="checkbox"/> 23:00

Sunday Monday

Tuesday Wednesday

Thursday Friday

Saturday

Scheduled Server Mode Screen

How Does the CNI2e Know What Day It Is?

In order to enter and exit Server Mode at specific time of the day and days of the week the CNI2e needs to know the current time and date. Shortly after a power up or reset, and if a Server schedule has been defined, the CNI2e will attempt to call one of five time servers managed by the United States National Institute of Standards and Technology (NIST). This call will last approximately 20 – 30 seconds and will be the first call after a power-up or reset.

Prior to V1.9 firmware (CNI2e-C) and with V1.0 firmware (CNI2e-H), these were the NIST time servers used:

132.163.4.101	Port-13	(Boulder, CO)
132.163.4.102	Port-13	(Boulder, CO)
132.163.4.103	Port-13	(Boulder, CO)
129.6.15.28	Port-13	(Gaithersburg, Md)
208.66.175.36	Port-13	(Chicago, IL)

Starting with V1.9 firmware (both CNI2e-C and -H), these are the NIST time servers used:

64.113.32.5	Port-13	(Southfield, MI.)
216.228.192.69	Port-13	(La Grande, OR)
98.175.203.200	Port-13	(Macon, GA)
198.111.152.100	Port-13	(Carsen City, MI)
128.138.140.44	Port-13	(Boulder, CO (U of C))

If it is unable to obtain the time it will try again every 30 minutes. Until then the CNI2e will not be able to follow the Server schedule.

Once the time and date are obtained the CNI2e will attempt to contact a NIST time server every four days to update its time values.

NOTE

The time and date obtained from a NIST time server is only used to schedule Server sessions. It is not used for call scheduling or time-tagging of pulse data or alarm events.

Specifying an Alternate Time Server

MP32 has provisions to define a 6th time server. If one is specified, that server is tried first followed by calls to the other five should the call to the first one fail.

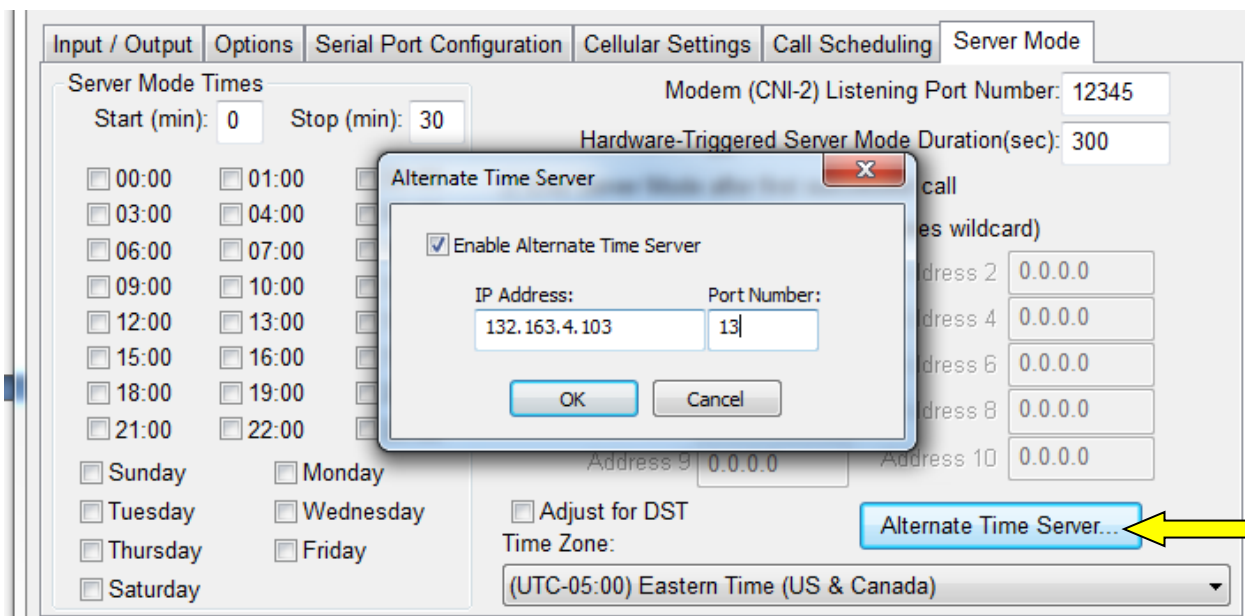

Specifying an Alternate Time Server

A list of NIST time servers can be found at <http://tf.nist.gov/tf-cgi/servers.cgi>.

In some situations the CNI2e may not be allowed to call a public server such as a NIST time server. The alternate time server may have to reside on your own host system. The alternate time server must follow Daytime Protocol RFC-867. We have a document that describes this protocol in detail.

Other Methods of Obtaining the Current Time and Date

- If the CNI2e is configured as a Mercury MMX or PA device, then the CNI2e can obtain the time and date from PowerSpring's Mercury Server or from MasterLink.
- If the CNI2e is configured as an InvisiConnect device, InvisiConnect can provide the time and date to the CNI2e. InvisiConnect's "Provide Date/Time Updates to Remote Device" box must be checked as shown below.

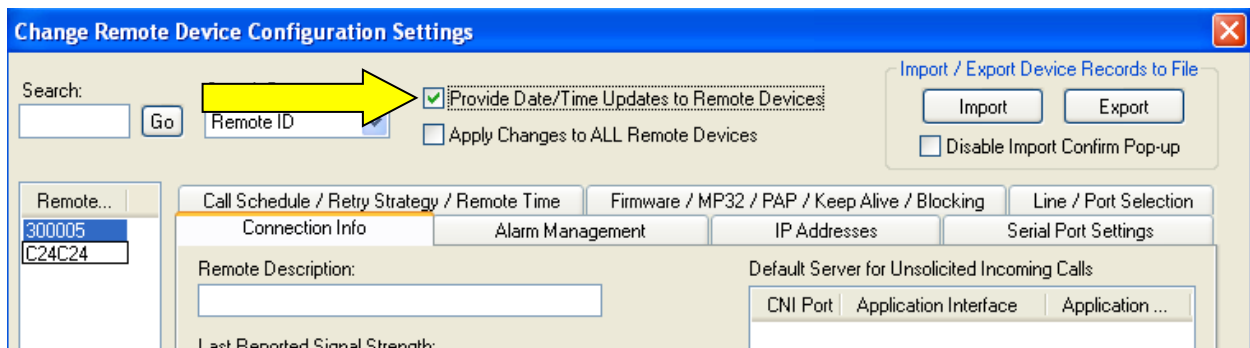

Providing the Time from InvisiConnect

InvisiConnect only accepts calls from a CNI2e. Therefore the CNI2e would have to be configured to call in to InvisiConnect at least once to get the time and date. In order to ensure accuracy the CNI2e should call back every so often to obtain a time update. This can be scheduled using InvisiConnect's Time Sync feature.

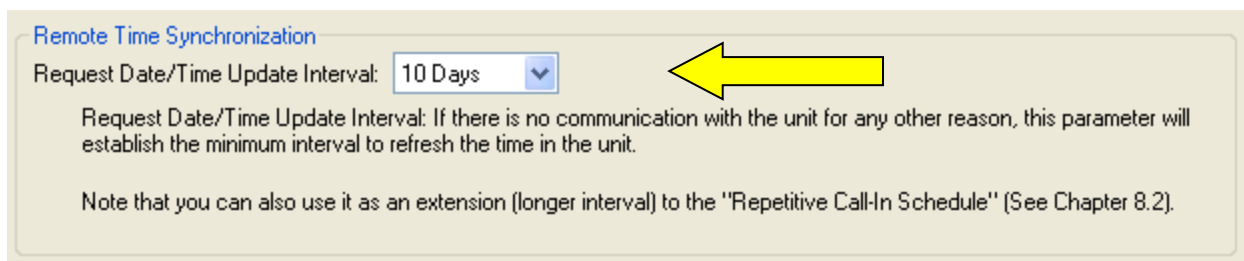

InvisiConnect's Time Sync feature

Daylight Savings Time (DST) adjustment

If the CNI2e is located in an area that observes Daylight Savings Time (DST), and you would like the CNI2e to make that adjustment automatically, check the “*Adjust for DST*” box on the *Server Mode* screen.

Example: In the United States DST starts on the 2nd Sunday in March and ends on the 1st Sunday in November. If the “*Adjust for DST*” box is checked the CNI2e will add one hour to the NIST time between these dates.

NOTE

DST adjustment only applies to the time and date obtained from a NIST time server, which is only used to schedule Server sessions.

It is not applied to the time that is obtained from a data collection server such as PowerSpring® or MV90®, which is used for call scheduling or time-tagging of pulse data or alarm events.

Time Zone Adjustment

The time and date that is obtained from a NIST time server is Universal Coordinated Time (UTC) which is essentially the same thing as Greenwich Mean Time (GMT). It is not adjusted for the time zone in which the CNI2e is located.

You may want the time to be accurate for the geographic location of the CNI2e, or perhaps where the client’s computer is located. You can make this selection on the *Server Mode* Screen.

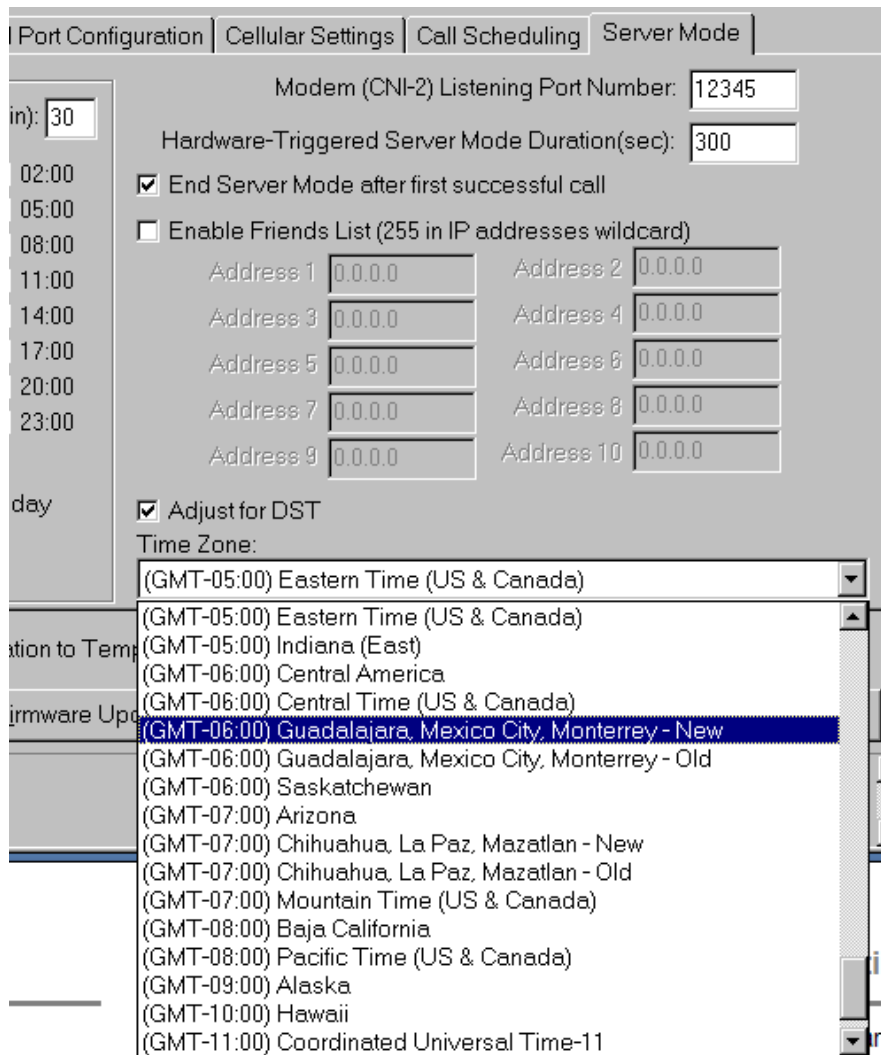

CNI2e Server Time Adjustment

NOTE

Time Zone adjustment only applies to the time and date obtained from a NIST time server, which is only used to schedule Server sessions.

It is not applied to the time that is obtained from a data collection server such as PowerSpring® or MV90®, which is used for call scheduling or time-tagging of pulse data or alarm events.

Example #1: The CNI2e is located in Mexico City. By selecting the “Mexico City” setting the CNI2e will subtract six hours from the time that was received from the NIST time server.

Example #2: The CNI2e is located in Mexico City but the client’s computer system is located in New York, which is in the Eastern Time zone. By selecting the “Eastern Time” setting the CNI2e will subtract five hours from the time that was received from the NIST time server.

Early Termination of a Server Session

A Server session must last long enough for a client to make contact with the CNI2e. But in battery-operated units it is also important to minimize this time to conserve power.

Suppose a Server session is scheduled to last 15 minutes. If the client makes contact with the CNI2e within the first few minutes then the rest of the 15-minute time slot is likely not needed and is a waste of power. By checking the “*End Server Mode after First Successful Call*” box the current Server session will end as soon as the first successful connection occurs, regardless of the remaining schedule or time duration settings.

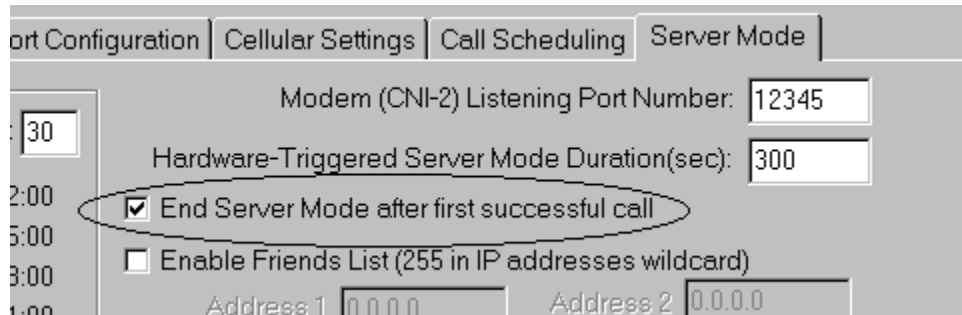

Early Termination of a Server Session

NOTE

If the Server session was started by a hardware input line, and that input line is still active when the session is terminated early, a new Server session will be started immediately.

Example: The CNI2e is scheduled to go into Server Mode between 10:15 and 10:45. The client makes contact with the CNI2e at 10:20. Once the connection completes the Server Mode is terminated shortly after 10:20.

Interruption of a Server Session

While waiting for connection request from a remote client there are several ways this can be interrupted:

- 1) The “*Originate Connections*” box is checked and...
 - a. A hardware or event alarm occurs and the CNI2e is configured to call in to report it
 - b. The CNI2e is scheduled to call in at a specific time of the day to report pulse data,
 - c. The CNI2e receives a dial command from the device connected to its serial port.

- 2) The “*Respond to Voice Calls*” box is checked and...
 - a. The CNI2e receives a voice call (page) or a CSD call.

However once a remote client connects to the CNI2e that session will be allowed to complete and will not be interrupted by any of the events mentioned above.

Depending upon how the CNI2e is configured it may return to listening for a connection request after the interruption.

Example: The CNI2e is scheduled to listen for a connection request between 8:00AM – 8:45AM. At 8:15AM an alarm condition occurs that must be reported immediately. The CNI2e terminates the Server session and establishes a Client connection to a data collection system such as PowerSpring®. Once the call has finished there is still time remaining on the Server schedule, so the CNI2e will reopen a listening channel and will continue to listen for a connection request until 8:45AM.

Connections to a Specific Serial Port

In addition to the CNI2e having its own listening port its serial port has one too.

The screenshot shows the 'Serial Port Configuration' tab of a software interface. It includes a table of port configurations, various dropdown menus for settings like Max BPS, Data Bits, Parity, Stop Bits, and Flow Control, and several checkboxes for advanced options. A yellow arrow points to the 'Listening Port' field, which contains the value '40000'.

Port #	Port ID
Port 1	123456
Port 2	000002
Port 3	000003
Port 4	000004
Port 5	000005
Port 6	000006
Port 7	000007
Port 8	000008

Port Select ID: 123456
Max BPS: 9600
Data Bits: 8
Parity: None
Stop Bits: 1
Flow Control: None
Delay before sending packets: 0 mS
Listening Port: 40000

Always send Connect Message
Always "RING" port
Use non-verbose result codes
Enable Blocking
Connect on DTR High
Disconnect on DTR Low
Use Alternate Connect Message
Alternate Connect Message:

Serial Port Listening Port Number

Example

The CNI2e is configured as a Metretek SIP data logger with a listening port of 12345. There is also an electric meter attached to Serial Port-1 with a listening address of 40000. In one instance the PowerSpring® data collection system may wish to gather pulse information and would use port number 12345 to obtain this information. There is also another system that needs information from the electric meter and doesn't know anything about a data logger. In this case it would address port number 40000. The CNI2e will make a direct connection to the electric meter when it receives a connection request to this port number.

NOTE
Do not use a Listening Port number of 0 (zero).

PROGRAMMING THE CNI2E

Loading a Configuration with the Programming Cable

IMPORTANT NOTE

Programming the configuration into a CNI2e automatically resets the unit and clears all accumulated data.

- 1) Make sure the proper COM port is selected (see the very beginning of this chapter).
- 2) Attach the cable to the computer (either a serial connection or a USB connection).
- 3) Attach the opposite end of the interface cable to the 6-position connector on the CNI2e board. The connector is keyed and can only insert in one direction.

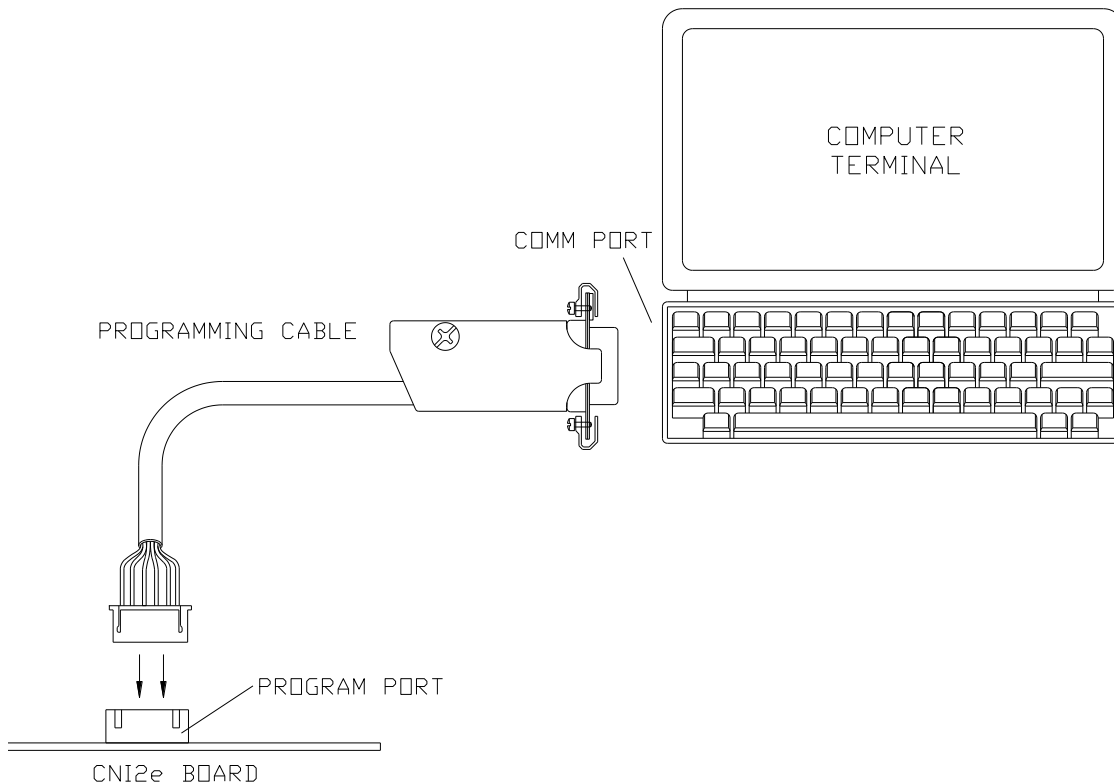

Attaching the Programming Cable

- 4) Select the *PROGRAM* button to start programming the CNI2e. Status messages will appear in the lower left-hand corner of the screen and should end with an “Operation Successful” message. If an error occurs check your cable and serial port settings. During programming the RED and GREEN LEDs may light as data is being transferred between the CNI2e and MP32®.
- 5) When programming has completed, unplug the cable from the CNI2e board. The CNI2e is now ready to be put into service.

OVER-THE-AIR (OTA) PROGRAMMING

What is Over-the-Air Programming?

The CNI2e's configuration and/or its operating program (called "firmware") can be changed once the unit is installed in the field. This is called over-the-air (OTA) programming. At the present time this feature is only supported when using the PowerSpring® data collection system or InvisiConnect®, and then only in Internet (IP) mode. MV90® does not support OTA changes and PowerSpring® and InvisiConnect® do not support OTA in CSD mode.

NOTE

The remote unit ID (RUID) and Service Type (GSM, HSPA or CDMA) cannot be changed over-the-air. These can only be changed using a programming cable.

WARNING

In some case and in some countries (Canada for example) a metering device is not allowed to have its program or configuration changed over-the-air.

Over-the-Air Configuration Changes Using PowerSpring®

IMPORTANT

**It is extremely important that all configuration parameters be correct, especially those related to the cellular network.
Otherwise the CNI2e may not be able to contact the central office again.
This will require an on-site visit to correct the problem.**

Both MP32® and PowerSpring® must be running on the same system at the same time. The *PROGRAM ACCOUNTS / LISTS* button on the bottom of the main MP32 screen will be enabled only when both programs are running.

Set up all configuration items as you would for any CNI2e. Then select the *PROGRAM ACCOUNTS / LISTS* button on the bottom of the main MP32 screen. The following screen will appear.

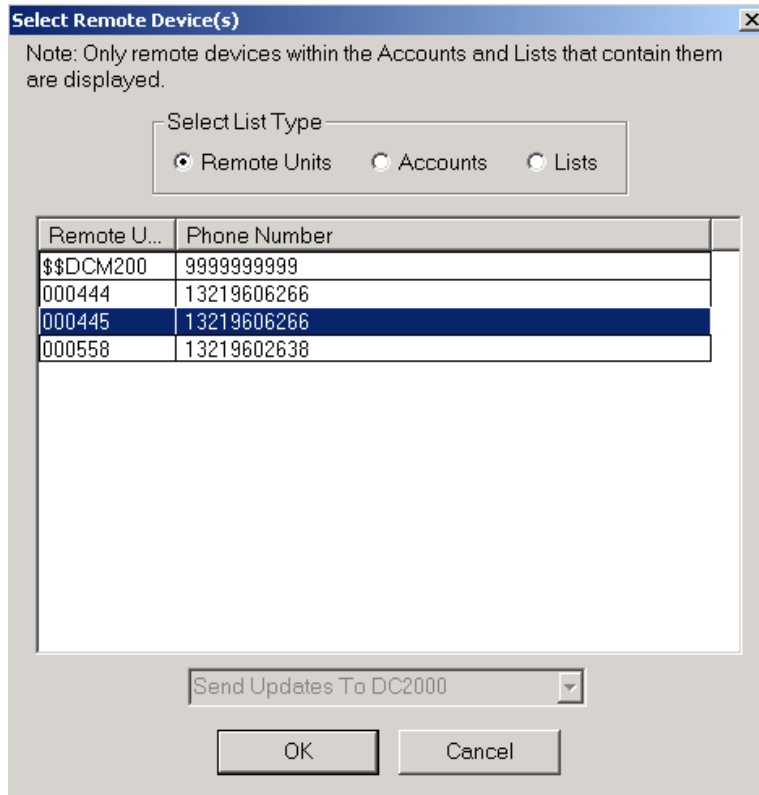

PowerSpring OTA Device Selection Screen

Since the remote unit ID (RUID) cannot be changed over-the-air it is possible to change the configuration for 1000's of devices in one simple operation using the *Accounts* or *Lists* selections, or simply one at a time using the *Remote Units* selection. Then highlight the desired units.

When the *OK* button is selected the configuration information is saved in PowerSpring's database. This new configuration will be loaded into each CNI2e the next time it calls in. If for any reason the configuration update cannot be completed due to a network problem or a data error the original configuration will remain in effect until the new one can be transmitted.

Over-the-Air “Firmware” Changes Using PowerSpring®

The CNI2e’s operating software, also called “firmware”, can be changed over-the-air. Both MP32® and PowerSpring® must be running on the same system at the same time.

1. Select the *FIRMWARE UPDATE* button on the bottom of the main MP32 screen.
2. We will provide a software file that contains the new firmware code. Enter the filename into the *Firmware Filename* box or use the browse button to locate it on the disk drive.

WARNING

**It is extremely important to select the correct firmware file.
Otherwise the CNI2e may not be able to contact the central computer again.
This will require an on-site visit to correct the problem.**

3. Select the *SEND FIRMWARE UPDATE TO PowerSpring* button. This button will be enabled only when both MP32® and PowerSpring® must be running on the same system at the same time.
4. See the previous screen shot. It is possible to change the firmware for 1000’s of devices in one simple operation using the *Accounts* or *Lists* selections, or simply one at a time using the *Remote Units* selection. Then highlight the desired units.
5. When the *OK* button is selected the firmware information is saved in PowerSpring’s database. This new firmware will be loaded into each CNI2e the next time it calls in.

If for any reason the firmware update cannot be completed due to a network problem or a data error the old firmware will remain in effect until the new one can be transmitted.

RECOMMENDATION

Try an over-the-air firmware update on a CNI2e that is located in your office first!
If you’ve selected the wrong file you will be able to correct it before sending it to units that are located in the field.

The CNI2e does not replace its firmware until after the call has completed. During the time that the CNI2e is reprogramming itself the green and red LEDs will alternately flash at a rapid rate. This can take up to 15 seconds to complete.

Over-the-Air Configuration Changes Using InvisiConnect®

NOTE

Over-the-air configuration changes require V5.5.0 or later of the InvisiConnect® software.

IMPORTANT

It is extremely important that all configuration parameters be correct, especially those related to the cellular network.

Otherwise the CNI2e may not be able to contact the central office again. This will require an on-site visit to correct the problem.

A configuration template must be created by the MP32 configuration program. MP32 will create a file with a ".CI2" extension for the CNI2e product. This is the only extension that InvisiConnect® will accept.

Over-the-air configuration changes are scheduled by selecting InvisiConnect's *Remote Device Configuration Settings* screen.

1. Highlight the *remote unit ID* for the device you wish to change.
2. Select the *FIRMWARE/MP32* tab.
3. In the lower portion of the screen enter the filename that was created by MP32 (example shown below).
4. Finally select the *APPLY* button.

InvisiConnect® OTA Configuration Screen

The configuration will be updated the next time the unit calls in. If the CNI2e has been configured as a Metrotek SIP going through InvisiConnect® then the configuration is changed after the CNI2e has completed its transaction with PowerSpring® or MV90®.

The CNI2e does not replace its configuration until after the call has completed. During the time that the CNI2e is reprogramming itself the green and red LEDs will alternately flash at a rapid rate. This can take up to 2 seconds to complete.

Over-the-Air Firmware Changes Using InvisiConnect®

NOTE

Over-the-air firmware changes require V5.5.0 or later of the InvisiConnect® software.

IMPORTANT

It is extremely important to select the correct firmware file. Otherwise the CNI2e may not be able to contact the central computer again. This will require an on-site visit to correct the problem.

You will be supplied with a firmware files with a “.HEX” extension. This is the only extension that InvisiConnect® will accept.

Over-the-air firmware changes are scheduled by selecting InvisiConnect’s *Remote Device Configuration Settings* screen.

1. Highlight the *remote unit ID* for the device you wish to change.
2. Select the *FIRMWARE/MP32* tab.
3. In the lower portion of the screen enter the filename that was provided (example shown in the next screenshot).
4. Finally select the *APPLY* button.

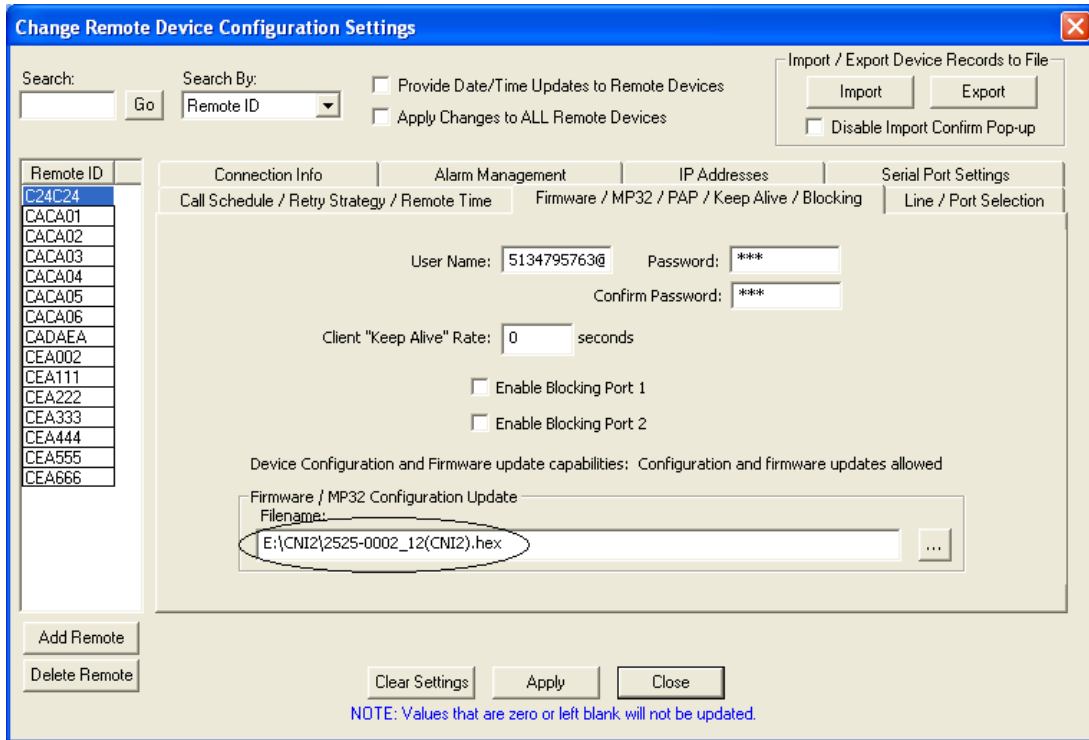

InvisiConnect® OTA Firmware Screen

The firmware will be updated the next time the unit calls in. If the CNI2e has been configured as a Metretek SIP going through InvisiConnect® then the firmware is changed after the CNI2e has completed its transaction with PowerSpring® or MV90®.

If for any reason the firmware update cannot be completed due to a network port problem or a data error the old firmware will remain in effect until the new one can be transmitted.

RECOMMENDATION

Try an over-the-air firmware update on a CNI2e that is located in your office first! If you've selected the wrong file you will be able to correct it before sending it to units that are located in the field.

The CNI2e does not replace its firmware until after the call has completed. During the time that the CNI2e is reprogramming itself the green and red LEDs will alternately flash at a rapid rate. This can take up to 15 seconds to complete.

MERCURY INSTRUMENTS EMULATION

Some data collection systems may not support Metrotek devices but may support Mercury Instruments devices. The CNI2e can emulate either a Mercury *Pulse Accumulator* or a *Mini-Max* corrector (pulse and alarm information only, the CNI2e does not measure pressure or temperature or perform any calculations based on these two measurements).

PowerSpring[®], Masterlink[®] and AutoSol[®] support both of these instruments. MV90[®] can support either instrument depending upon which options were purchased for MV90[®].

WHAT ARE ITEM CODES?

An “Item Code” is a 3-digit number that describes the information to be written to or read from a Mercury device. For example, Item-203 is used to load or read the current time and Item-204 the current date.

Not all Mercury devices support all Item Codes. For example, since a real *Mini-Max* measures gas pressure, it supports Item-8, which is the current gas pressure reading. But a *Pulse Accumulator* knows nothing about gas pressure. Most data collection programs would know not to ask a *Pulse Accumulator* for Item-8. But if it were asked for Item-8, a real *Pulse Accumulator* would respond with a “Not Supported” error message.

DIFFERENCES BETWEEN METRETEK AND MERCURY DEVICES

- For the CNI2e to emulate a *Pulse Accumulator* or *Mini-Max* it will respond to nearly 350 Item Codes that are a combination of codes supported by both instruments. So in the previous example, if the CNI2e is configured as a *Pulse Accumulator* and is asked for Item-8, it will respond with a value of 0.0 rather than “Not Supported”. Some programs like Masterlink[®] allow certain items to be written into, including Item-8. If this happens, and the CNI2e is then asked for Item-8, it will report the new value instead of 0.0.
- Metrotek pulse accumulators gather and report raw pulse counts. If these counts need to be corrected or converted to some other value, this is done by the data collection system, namely PowerSpring[®]. Mercury Instruments devices also gather raw pulse counts. However, if these counts need to be corrected or converted to some other value, this is generally done by the instrument before being reported to the data collection system. There are many Item Codes that a Mercury device uses to correct and convert these counts. These are described shortly.
- Newer versions of a real *Mini-Max* support what is known as Event Logs and Alarm Logs. A real *Pulse Accumulator*, as well as the CNI2e, does not currently support these features.
- A Metrotek pulse accumulator can gather and report pulse counts from four independent sources. A *Pulse Accumulator* is limited to two channels, and a *Mini-Max* one channel. If the CNI2e is configured as a *Mini-Max* it can report the 2nd channel's information if it is asked for that information. However most data collection systems are not designed to ask for a 2nd channel of information from a *Mini-Max*.

- Over-the-air firmware changes are not supported when acting as a Mercury device.
- Over-the-air configuration changes are allowed for a small subset of items, but not all of the items that are possible. These are described shortly.

WRITE-PROTECTED ITEM CODES

Attempting to write into these Items will result in an “Access Denied” (32) or “Invalid Change Attempted” (39) error code.

ITEM CODE	DESCRIPTION	COMMENTS
48	Battery voltage reading	Returns current system voltage reading
49	Low battery alarm point	Can only be configured by MP32
50	Shutdown voltage limit.	Preset to 3.3V
122	Firmware version.	Returns “2.82” for Mini-Max or “3.13” for Pulse Accumulator
126	Serial port baud rate.	Can only be changed with MP32
127	Instrument type.	Returns “4” for Mini Max or “8” for Pulse Accumulator
202	Logging (time-tagged) Interval	Can only be configured by MP32.
450	Memory capacity.	Preset value based on hardware
481	Maximum audit trail record capacity	Calculated based on number of audit trail items to be recorded. See discussion about Audit Trail Size.
843	Scheduled call-in failures	Running total of failed call attempts
844	Last Scheduled call-in time	The last time a call-in was attempted
845	Last Scheduled call-in date	The last date a call-in was attempted
846	Next Scheduled call-in time	The next time a call-in will be attempted
847	Next Scheduled call-in time	The next date a call-in will be attempted

Write-protected Item Codes

ITEM CODES PROTECTED BY ITEM-139

Item-139 is used to protect some or all other item codes from being changed, as follows:

- 0 = Full read/write access.
- 1 = Read access only, no write access is permitted
- 2 = No read/write access from the local serial port
- 3 = Full read/write access except for metrological items

NOTE

A "Metrological" item is any item that affects the accuracy of the pulse-count readings. Examples include scaling factors, calibration constants, energy-related conversion factors, etc.

Item-139 is also considered a metrological item. If you write 1, 2 or 3 into Item-139, you will not be able to change it back to 0. Therefore writing to Item-139 should be the last thing you do before putting the CNI2e into service.

If Item-139 is set to 2 and an attempt is made to access the items via the local serial port (for instance using Masterlink®), the CNI2e will return the "Access Denied" (32) error code.

Attempting to write into items protected by Item-139 will result in an "Access Denied" (32) or "Invalid Change Attempted" (39) error code.

MULTIPLE ACCESS ITEM CODES

Most of the CNI2e's configuration values can only be specified or changed using the MP32 configuration program. But some values have a similar meaning to Mercury Item Codes. These are listed in the next table. Most can be changed by either MP32 or any software that supports Mercury protocol on a first-come, first-served basis. Any exceptions are listed in the next table.

ITEM CODE	DESCRIPTION	COMMENTS
333	Call-in Trigger	<p>If the "Originate Calls" box is checked in MP32 then the CNI2e will always be allowed to make scheduled calls. When read Item-333 will return a value of "2" meaning that scheduled call-ins are allowed. The CNI2e will also be allowed to make alarm call-ins if any alarm input is configured to do so and the "Originate Calls" box is checked. In this case Item-333 will return a value of "3" meaning that both scheduled and alarm call-ins are allowed.</p> <p>If Item-333 is set to "0" (None) then the "Originate Calls" box in MP32 will be unchecked and the CNI2e will not be able to call-in for any reason. For any other value written into Item-333 the CNI2e will always be allowed to make scheduled calls and will also be allowed to make alarm calls if any alarm input is configured to do so by MP32</p>
495	Primary retry interval	The rate (in minutes) that the CNI2e will attempt to retry a failed call. Legal range is 0 – 255 minutes.
496	Secondary retry interval	<p>The rate (in minutes) that the CNI2e will attempt to retry a failed call after the Primary Retry Count has been exhausted.</p> <p>NOTE:</p> <p>The CNI2e converts this value to hours and truncates any remainder. For instance any value between 61 and 119 minutes will be treated as 1 hour, or 60 minutes.</p>
497	Primary retry count	The number of times the CNI2e will attempt to retry a failed call at the Primary Retry Interval before switching to the Secondary Retry Interval. Legal range is 0 – 255 retries.
339	Scheduled Call-in Phone Number or IP Address	Used for all scheduled call-ins or any call to report events not related to hardware inputs (such as low-battery alarms).
493	Alarm Call-in Phone Number or IP Address	Used for any hardware alarm input that is configured (by MP32) to generate a call.
485	Call-out Stop Time	Time to stop accepting incoming calls. See the discussion on "Server Mode Item Codes" for more information.

ITEM CODE	DESCRIPTION	COMMENTS
487	Call-in Keep Alive Time	Amount of time to accept incoming calls after calling in. See the discussion on “Server Mode Item Codes” for more information.
488	Call-out Repeat Interval	See the discussion on “Server Mode Item Codes” for more information.
489	Call-out Keep Alive Time	Amount of time to accept incoming calls. See the discussion on “Server Mode Item Codes” for more information.
490	Call-out Start Time	Time to start accepting incoming calls. See the discussion on “Server Mode Item Codes” for more information.

Multiple Access Item Codes

SERVER MODE (“CALL-OUT”) ITEM CODES

There may be times when it is desired to contact the CNI2e rather than waiting for it to call in. Earlier in this document we discussed “Server Mode”. In Mercury language this is also referred to as “Call-Out” mode, allowing a host computer system to “call out” to a Mercury device during particular time slots throughout the day. It would be best to review the [“Server Mode”](#) section in order to understand how Server (Call-Out) mode works and how the Mercury “Call-Out” Item Codes relate to the CNI2e’s server capabilities.

NOTE

In order to accept incoming calls the radio must remain powered up. This has a great impact on battery life and should be used wisely in battery-operated units.

There are five item codes related to the “Call-Out”, or “Server” features.

ITEM CODE	DESCRIPTION
485	Call-out Stop Time
487	Call-in Keep Alive Time
488	Call-out Repeat Interval
489	Call-out Keep Alive Time
490	Call-out Start Time

Server Mode (“Call-Out”) Item Codes

Item-487 (Call-in Keep Alive Time)

After the CNI2e calls in to the host system it usually powers down the radio and other non-essential components and enters a low-power standby mode. But based on what was reported on that call, the host system may want to request more information. But it would have to wait for the next call-in event to get that information. If Item-487 is some value other than 0, the CNI2e will enter Server (Call-Out) mode immediately after each call-in to allow the host system time to call back for more information. Item-487 is the time, in minutes, to remain in this mode.

If Item-487 is written into, the MP32 value called "Server Mode Duration" is replaced by this time value multiplied by 60. For instance if Item-487 is 10 (minutes), the "Server Mode Duration" is replaced by 600 (seconds).

Conversely if MP32 modifies the "Server Mode Duration", this value is divided by 60 and written into Item-487. During this computation any remainder is truncated. For instance any value between 601 and 659 seconds will be result in an Item-487 value of 10 minutes.

NOTE

On MP32's Server Mode screen is a checkbox called "End Server Mode After First Successful Call". This checkbox can only be modified by MP32.

Suppose Item-487 is set for 10 minutes. After a successful call-in the CNI2e enters Server Mode for the next 10 minutes. The host system calls back in 3 minutes. If the "End Server Mode After First Successful Call" box is checked, Server Mode will be terminated after the host completes its call. If the box is unchecked, the CNI2e will remain in Server Mode for another 7 minutes.

Item-488 (Call-out Repeat Interval)

This item is not used for Server mode.

Item-490 (Call-out Start Time)

Item-485 (Call-out Stop Time)

Item-489 (Call-out Keep Alive Time)

These three items are used to create what is called a "Scheduled Server Session". These are periods of time throughout each day that the CNI2e will enter Server mode.

The Call-out Start Time (Item-490) defines the first time each day to start Server mode. Once started, the CNI2e will remain in this mode for a period of time (in minutes) defined by the Call-out Keep Alive Time (Item-489). This sequence will be repeated every hour until the Call-out Stop Time (Item-485) is reached.

Example: The Call-out Start Time is set for 10:15:00. The Call-out Stop Time is set for 16:30:00. The Call-out Keep Alive Time is set for 7 minutes.

Starting at 10:15:00 each day the CNI2e will enter Server Mode for 7 minutes (ending at 10:22). This sequence repeats at 11:15, 12:15 and 13:15, 14:15, 15:15 and 16:15. Since the Stop Time

was set for 16:30:00, this will be the end of the Server Mode for that day. The sequence will start over the next day at 10:15:00 and will continue each day thereafter.

Here is how the Mercury Item Code and MP32 settings are affected by each other:

How Changes to Call-Out Items Affect MP32's Server Mode Settings

Changes to Items-490, 485 and 489 will only affect MP32's Server Mode settings if:

- a) The Call-out Keep Alive Time (Item-489) is something other than 0.
- b) The Call-out Stop Time (Item-485) occurs after the Call-out Start Time (Item-490).

Mercury Protocol does not support the ability to select particular days for Server mode to occur. However MP32 does. Here is what happens if the conditions mentioned above are met:

- a) MP32's "Allow Connection Requests" box is checked.
- b) All seven days-of-the-week (*Sunday, Monday, etc.*) boxes are checked, meaning that the Scheduled Server Session will occur every day.
- c) MP32's *Server Mode Start Time* is set to the minutes past the hour specified in the Call-out Start Time (Item-490). For example if Item-490 is 14:35:00, the *Server Mode Start Time* field will contain "35".
- d) MP32's *Server Mode Stop Time* is the sum of the minutes past the hour specified in the Call-out Start Time (Item-490) and the Call-out Keep Alive Time (Item-489). For example if Item-490 is 14:35:00 and Item-489 is 12 minutes, then the *Server Mode Stop Time* field will contain "47" (35 + 12). If the sum exceeds 59 minutes, the field will contain "59".
- e) MP32's *Server Mode Times* boxes will be checked to cover the full range between the Call-out Start Time (Item-490) and the Call-out Stop Time (Item-485). Example: The Call-out Start Time is set for 10:15:00. The Call-out Stop Time is set for 16:30:00. The time slot boxes will be checked as seen in the following screenshot:

Server Mode Times

Start (min): Stop (min):

<input type="checkbox"/> 00:00	<input type="checkbox"/> 01:00	<input type="checkbox"/> 02:00
<input type="checkbox"/> 03:00	<input type="checkbox"/> 04:00	<input type="checkbox"/> 05:00
<input type="checkbox"/> 06:00	<input type="checkbox"/> 07:00	<input type="checkbox"/> 08:00
<input type="checkbox"/> 09:00	<input checked="" type="checkbox"/> 10:00	<input checked="" type="checkbox"/> 11:00
<input checked="" type="checkbox"/> 12:00	<input checked="" type="checkbox"/> 13:00	<input checked="" type="checkbox"/> 14:00
<input checked="" type="checkbox"/> 15:00	<input checked="" type="checkbox"/> 16:00	<input type="checkbox"/> 17:00
<input type="checkbox"/> 18:00	<input type="checkbox"/> 19:00	<input type="checkbox"/> 20:00
<input type="checkbox"/> 21:00	<input type="checkbox"/> 22:00	<input type="checkbox"/> 23:00

<input checked="" type="checkbox"/> Sunday	<input checked="" type="checkbox"/> Monday
<input checked="" type="checkbox"/> Tuesday	<input checked="" type="checkbox"/> Wednesday
<input checked="" type="checkbox"/> Thursday	<input checked="" type="checkbox"/> Friday
<input checked="" type="checkbox"/> Saturday	

Server Mode Results of Item Code Changes

NOTE

Once the Call-Out Item codes are written, you can use MP32 to turn off certain days, such as Saturday and Sunday. Changes to other times will result in changes to the Item Codes, as discussed in the next section.

How Changes to MP32's Server Mode Setting Affect the Call-Out Item Codes

MP32 offers more flexibility with Server Mode settings. For instance Mercury Protocol does not support the ability to select particular days for Server mode to occur. However MP32 does.

In the next example we used MP32 to setup a Scheduled Server Mode.

Server Mode Times
Start (min): 30 Stop (min): 45

<input type="checkbox"/> 00:00	<input type="checkbox"/> 01:00	<input type="checkbox"/> 02:00
<input type="checkbox"/> 03:00	<input type="checkbox"/> 04:00	<input type="checkbox"/> 05:00
<input type="checkbox"/> 06:00	<input checked="" type="checkbox"/> 07:00	<input type="checkbox"/> 08:00
<input type="checkbox"/> 09:00	<input type="checkbox"/> 10:00	<input type="checkbox"/> 11:00
<input type="checkbox"/> 12:00	<input checked="" type="checkbox"/> 13:00	<input type="checkbox"/> 14:00
<input type="checkbox"/> 15:00	<input type="checkbox"/> 16:00	<input type="checkbox"/> 17:00
<input type="checkbox"/> 18:00	<input checked="" type="checkbox"/> 19:00	<input type="checkbox"/> 20:00
<input type="checkbox"/> 21:00	<input type="checkbox"/> 22:00	<input type="checkbox"/> 23:00

Sunday Monday
 Tuesday Wednesday
 Thursday Friday
 Saturday

Example Scheduled Server Mode

The CNI2e will enter Server Mode three times each day except Saturdays and Sundays. The time slots are 07:30 to 07:45, 13:30 to 13:45 and 19:30 to 19:45,

Here is how the Call-Out Item Codes are affected:

- The Call-out Start Time (Item-490) will be set to 07:30:00 because this is the first time each day that Server Mode will be entered.
- The Call-out Stop Time (Item-485) will be set to 19:45:00 because this is the time when the final Server Mode time slot will end.
- The Call-out Keep Alive Time (Item-489) will be set to 15 minutes, which is the amount of time the CNI2e will remain in Server Mode for each time slot.

NOTE

If MP32's "Allow Connection Requests" box is unchecked, all Call-Out Item Codes will be reset to 0.

MEASUREMENT (PULSE-COUNTING) ITEM CODES

Mercury Instruments devices gather (and can report) raw pulse counts. However, if these counts need to be corrected or converted to some other value, this is generally done by the device before being reported to the data collection system. There are many Item Codes that a Mercury device uses to correct and convert these counts.

NOTE

The CNI2e has multiple input lines that can be configured as pulse-counting inputs. The very 1st line configured for pulse-counting is called "Channel-1". The 2nd line configured for pulse-counting is called "Channel-2".

ITEM CODE	LEGACY DESCRIPTION as a MINI-MAX	LEGACY DESCRIPTION as a PULSE ACCUMULATOR
0	Corrected Volume	Channel-1 Fixed Factor Volume
2	Uncorrected Volume	Channel-1 Accumulated Volume
44	Pressure Correction Factor	Channel-1 Fixed Factor Value
90	Corrected Volume Units	Channel-1 Fixed Factor Volume Units
92	Uncorrected Volume Units	Channel-1 Accumulated Volume Units
98	Meter Index Rate	Channel-1 Input Pulse Value
114	Meter Scaling Factor	Channel-1 Input Pulse Scaling Factor
140	Energy	Channel-1 Energy
141	Energy Units	Channel-1 Energy Units
142	Gas Energy Value	Channel-1 Gas Energy Value
190	Daily Energy	Channel-1 Daily Energy
221	Daily Corrected Volume Alarm Limit	Channel-1 Daily Fixed Factor Volume Alarm Limit
222	Daily Corrected Volume Alarm Indicator	Channel-1 Daily Fixed Factor Volume Alarm Indicator
223	Daily Corrected Volume	Channel-1 Daily Fixed Factor Volume
224	Daily Uncorrected Volume	Channel-1 Daily Accumulated Volume
225	Incremental Corrected Volume	Channel-1 Incremental Fixed Factor Volume

ITEM CODE	LEGACY DESCRIPTION as a MINI-MAX	LEGACY DESCRIPTION as a PULSE ACCUMULATOR
226	Incremental Uncorrected Volume	Channel-1 Incremental Accumulated Volume
440	Channel-2 Fixed Factor Value	Channel-2 Fixed Factor Value
457	Channel-2 Fixed Factor Volume Units	Channel-2 Fixed Factor Volume Units
458	Channel-2 Accumulated Volume Units	Channel-2 Accumulated Volume Units
478	Daily Corrected Volume Alarm Time	Channel-1 Daily Fixed Factor Volume Alarm Time
478	Daily Corrected Volume Alarm Date	Channel-1 Daily Fixed Factor Volume Alarm Date
908	Channel-2 Fixed Factor Volume	Channel-2 Fixed Factor Volume
909	Channel-2 Incremental Fixed Factor Volume	Channel-2 Incremental Fixed Factor Volume
910	Channel-2 Accumulated Volume	Channel-2 Accumulated Volume
911	Channel-2 Incremental Accumulated Volume	Channel-2 Incremental Accumulated Volume
912	Channel-2 Input Pulse Value	Channel-2 Input Pulse Value
913	Channel-2 Input Pulse Scaling Factor	Channel-2 Input Pulse Scaling Factor

Measurement-Related Item Codes

Note-1: Shaded Items are not supported by a “real” Mini-Max but are supported by the CNI2e. Some data collection programs may not be designed to read or write these Item Codes from or to a Mini-Max.

What are “Volume Unit” Item Codes?

Items-90, 92, 457 and 458 are used in conjunction with other Item Codes to convert the raw pulse counts to some other more meaningful value. The value of the Item Code translates to a multiplier “VUm[Item]”. Example: If Item-457 is set for a value of 2 (CF x 100), then Vum[457] = 100.0.

VALUE	DESCRIPTION	MULTIPLIER (Vum[Item])
0 or 3	Cubic feet (CF)	1.0
1 or 4	Cubic feet (CF) X 10	10.0
2, 5 or 7	Cubic feet (CF) X 100	100.0
6 or 8	Cubic feet (CF) X 1000	1000.0
9	Cubic meters x 0.1	3.531467
10	Cubic meters	35.31467
11	Cubic meters x 10	353.1467
12	Cubic meters x 100	3531.467
13	Cubic meters x 1000	35314.67
14	Cubic meters x 10000	353146.7
15	Therms	100000.0
16	Dekatherms	1000000.0
17	Mega Joules	35314.67
18	Giga Joules	35314670.0
19	Kilo Calories	35.31467
20	Kilo Watt Hours	35314.67
21	Cubic feet (CF) X 100000	100000.0

Volume Unit Item Codes and Multipliers.

What are “Pulse Value” Item Codes?

Items-98 and 912 are used in conjunction with other Item Codes to convert the raw pulse counts to some other more meaningful value. The value of the Item Code translates to a multiplier “PVm[Item]”. Example: If Item-98 is set for a value of 12 (CF x 50), then PVm[98] = 50.0.

VALUE	DESCRIPTION	MULTIPLIER (PVm[Item])
0	Cubic feet (CF)	1.0
1	Cubic feet (CF) X 5	5.0
2	Cubic feet (CF) X 10	10.0
3	Cubic feet (CF) X 100	100.0
4	Cubic feet (CF) X 1000	1000.0
5	Cubic meters x 0.1	3.531467
6	Cubic meters	35.31467
7	Cubic meters x 10	353.1467
8	Cubic meters x 100	3531.467
9	Cubic meters x 1000	35314.67
10	Cubic meters x 10000	353146.7
11	Cubic feet (CF) x 0	0.0
12	Cubic feet (CF) X 50	50.0
13	Cubic feet (CF) X 500	500.0
14	Rotary Integral Mount	1.0

Pulse Value Item Codes and Multipliers.

What is the “Energy Unit” Item Code?

Item-141 is used in conjunction with other Item Codes to convert the raw pulse counts from Channel-1 only to some other more meaningful value. The value of the Item Code translates to a multiplier “Eum”. Example: If Item-141 is set for a value of 2 (CF x 100), then Eum = 35314.67.

VALUE	DESCRIPTION	MULTIPLIER (Eum)
0	Therms	100000.0
1	Dekatherms	1000000.0
2	Mega Joules	35314.67
3	Giga Joules	35314670.0
4	Kilo Calories	35.31467
5	Kilo Watt Hours	35314.67

Energy Unit Item Code and Multiplier.

What are “Scaling Factor” Item Codes?

Items-114 and 913 are used in conjunction with other Item Codes to convert the raw pulse counts to some other more meaningful value. The value of the Item Code translates to a multiplier “SFm[Item]”, which is any value between 0.0 and 200.0. Example: If Item-913 is set for a value of 2.3 then SFm [913] = 2.3.

What is the “Energy Value” Item Code?

Item-142 relates to the amount of energy per volume. It is always used to calculate the value for Item-140 (Energy).

Item-142 might also be used in the calculations for accumulated and fixed-factor volumes, but only when the Volume Unit item codes (Items-90, 92, 457 and 458) are set to a value between 15 and 20 (see the previous Volume Unit table). In these cases the multiplier “Evm” will equal the value in Item-142. Otherwise “Evm” = 1.0.

How are Pulse Counts Converted and Corrected?

If all you want are the raw pulse counts for the two channels then set the following Item Codes to these values:

ITEM CODE	LEGACY DESCRIPTION as a MINI-MAX	LEGACY DESCRIPTION as a PULSE ACCUMULATOR	Value to Obtain Raw Pulse Counts
44	Pressure Correction Factor	Channel-1 Fixed Factor Value	1.0
90	Corrected Volume Units	Channel-1 Fixed Factor Volume Units	7 (CF x 100)
92	Uncorrected Volume Units	Channel-1 Accumulated Volume Units	7 (CF x 100)
98	Meter Index Rate	Channel-1 Input Pulse Value	3(CF x 100)
114	Meter Scaling Factor	Channel-1 Input Pulse Scaling Factor	1.0
141	Energy Units	Channel-1 Energy Units	0
142	Gas Energy Value	Channel-1 Gas Energy Value	1.0
440	Channel-2 Fixed Factor Value	Channel-2 Fixed Factor Value	1.0
457	Channel-2 Fixed Factor Volume Units	Channel-2 Fixed Factor Volume Units	7 (CF x 100)
458	Channel-2 Accumulated Volume Units	Channel-2 Accumulated Volume Units	7 (CF x 100)
912	Channel-2 Input Pulse Value	Channel-2 Input Pulse Value	3 (CF x 100)
913	Channel-2 Input Pulse Scaling Factor	Channel-2 Input Pulse Scaling Factor	1.0

Raw Pulse Count Item Code Settings

There are quite a number of calculations involved for the various volume and energy readings. These are listed in the table on the next page.

ITEM CODE	LEGACY DESCRIPTION as a MINI-MAX (Pulse Accumulator)	CALCULATION
0	Corrected Volume (Channel-1 Fixed Factor Volume)	$(\text{Total Channel-1 Pulse Count}) \times (\text{Item-44}) \times (\text{Pvm}[98] / \text{Vum}[90]) \times \text{SFm}[114] \times \text{Evm}$
2	Uncorrected Volume (Channel-1 Accumulated Volume)	$(\text{Total Channel-1 Pulse Count}) \times (\text{Pvm}[98] / \text{Vum}[92]) \times \text{SFm}[114] \times \text{Evm}$
140	Energy (Channel-1 Energy)	$(\text{Total Channel-1 Pulse Count}) \times (\text{Item-44}) \times (\text{Pvm}[98] / \text{Eum}) \times \text{SFm}[114] \times (\text{Item-142})$
190	Daily Energy (Channel-1 Daily Energy)	$(\text{Channel-1 Daily Pulse Count}) \times (\text{Item-44}) \times (\text{Pvm}[98] / \text{Eum}) \times \text{SFm}[114] \times (\text{Item-142})$
223	Daily Corrected Volume (Channel-1 Daily Fixed Factor Volume)	$(\text{Channel-1 Daily Pulse Count}) \times (\text{Item-44}) \times (\text{Pvm}[98] / \text{Vum}[90]) \times \text{SFm}[114] \times \text{Evm}$
224	Daily Uncorrected Volume (Channel-1 Daily Accumulated Volume)	$(\text{Channel-1 Daily Pulse Count}) \times (\text{Pvm}[98] / \text{Vum}[92]) \times \text{SFm}[114] \times \text{Evm}$
225	Incremental Corrected Volume (Channel-1 Incremental Fixed Factor Volume)	$(\text{Channel-1 Interval Pulse Count}) \times (\text{Item-44}) \times (\text{Pvm}[98] / \text{Vum}[90]) \times \text{SFm}[114] \times \text{Evm}$
226	Incremental Uncorrected Volume (Channel-1 Incremental Accumulated Volume)	$(\text{Channel-1 Interval Pulse Count}) \times (\text{Pvm}[98] / \text{Vum}[92]) \times \text{SFm}[114] \times \text{Evm}$
908	Channel-2 Fixed Factor Volume (Channel-2 Fixed Factor Volume)	$(\text{Total Channel-2 Pulse Count}) \times (\text{Item-440}) \times (\text{Pvm}[912] / \text{Vum}[457]) \times \text{SFm}[913] \times \text{Evm}$
909	Channel-2 Incremental Fixed Factor Volume (Channel-2 Incremental Fixed Factor Volume)	$(\text{Channel-2 Interval Pulse Count}) \times (\text{Item-440}) \times (\text{Pvm}[912] / \text{Vum}[457]) \times \text{SFm}[913] \times \text{Evm}$
910	Channel-2 Accumulated Volume (Channel-2 Accumulated Volume)	$(\text{Total Channel-2 Pulse Count}) \times (\text{Pvm}[912] / \text{Vum}[457]) \times \text{SFm}[913] \times \text{Evm}$
911	Channel-2 Incremental Accumulated Volume (Channel-2 Incremental Accumulated Volume)	$(\text{Channel-2 Interval Pulse Count}) \times (\text{Pvm}[912] / \text{Vum}[457]) \times \text{SFm}[913] \times \text{Evm}$

Correction and Conversion Equations

THE AUDIT TRAIL SIZE

The Audit Trail is an area in memory where certain items (specified by you) are stored at the end of each measurement interval, or whenever an important event occurs such as an alarm or if the configuration of the CNI2e is changed.

The total size of this memory area is defined in terms of “bytes”. In MP32 you can choose one of two sizes; either 32K (which is actually 32768 bytes) or 60K (which is actually 61440 bytes).

The screenshot shows the MP32 configuration interface with several tabs: Input/Output, Options, Serial Port Configuration, Cellular Settings, Call Scheduling, and Server Mode. The 'Options' tab is active. Under 'Applications', 'Mercury Mini-Max' is selected. Under 'Over-the-air Capabilities', 'Both Allowed' is selected. The 'Operating Mode' section has 'Allow Transparent' unchecked. 'Low Battery Alarm' is set to 4.0 Volts, and 'Immediate call on low-battery condition' is checked. The 'Sample Rates' section shows 50/sec for Lines 1,2,9,10,11,12 and 0/sec for Lines 3,4,5,6,7,8. The 'Queue Size' section has '32K' selected with a radio button, and '60K' is unselected. 'Queue Full Alarm Point' is set to 75%. At the bottom, 'When answering, if no port select after 0 seconds, route to Port 1' is shown.

Selecting the Audit Trail Size in MP32

At minimum, if you elect not to store any Item Codes in the audit trail, the minimum record size for each entry is 10 bytes. There are 4 bytes that reflect the time and date of the entry, and 6 bytes that indicate alarm and event status known as the “T&A2” records. Therefore there can be as many as 3276 records stored for the “32K” setting, or 6144 records stored for the “60K” setting.

You can also specify up to 10 additional Items be stored with each entry. This is specified using Items-258, 259, 260, 261, 229, 230, 231, 232, 233, and 234. If any of these has a value of “255”, or is an unsupported Item Code, then nothing is stored for that item. Any other value should be a legal Item Code.

For example, suppose you wish to have Channel-1’s Fixed Factor Volume (Item-0), Channel-1’s Incremental Fixed Factor Volume (Item-225) and Channel-1’s Accumulated Volume (Item-2) stored in the Audit Trail. Set Item 259 = 0, 260 = 225 and 261 = 2, and the rest to 255. At the end of each measurement interval these three items, along with the time/date and T&A2 records, will be stored in the audit trail.

NOTE

When the Audit Trail memory becomes full, the oldest records are replaced by the newest records.

Each additional item to be stored occupies 8 bytes each. So in our example we have time/date (4 bytes), three other items (3 x 8 = 24 bytes) and the T&A2 records (6 bytes), for a total of 34 bytes per entry. Therefore there can be as many as 963 records stored for the “32K” setting, or 1807 records stored for the “60K” setting.

The maximum record size is reported in Item-481. It is recalculated any time something is added to or removed from the list of things to be recorded.

WARNING

Any time the Audit Trail configuration is changed, the Audit Trail is cleared and all previous records will be lost.

THE “T&A” AND “T&A2” EVENT RECORDS

The “T&A” and “T&A2” records, which are stored in the audit trail, are used to report certain events as they occur. Many of the individual event and alarm bits in these records are associated with pressure and temperature, neither of which is measured by the CNI2e.

The legacy “T&A2” record consists of 24 bits of information. The bits are labeled as follows:

ABCD EFGH IJKL MNOP QRST WXYZ

The legacy “T&A” record consists of 16 bits of information. The bits are labeled as follows:

ABCD MNOP QRST WXYZ

Bits ABCD indicate the reason that an entry was made into the audit trail:

- 0000 – Scheduled entry (usually the end of a pulse-counting interval)
- 0010 – Entry made due to an alarm condition.
- 0011 – Entry made due to an access from the serial port (usually done with MasterLink).
- 0111 – Entry made because some item was changed.
- 1000 – Entry made because the CNI2e was reset
- 1001 – Entry made because an alarm condition was cleared by command

Bits EFGH and IJKL are not currently used.

Bits MNOP, QRST and WXYZ are used to indicate a specific alarm condition:

- Bit-M: The 2nd CNI2e input configured as an ALARM input has gone active.
- Bit-N: The 1st CNI2e input configured as an ALARM input has gone active.
- Bit-O: Not currently used,
- Bit-P: The 5th CNI2e input configured as an ALARM input has gone active.
- Bit-Q: The 4th CNI2e input configured as an ALARM input has gone active.
- Bit-R: The 3rd CNI2e input configured as an ALARM input has gone active.
- Bit-S: Not currently used,
- Bit-T: Not currently used,
- Bit-W: Not currently used,
- Bit-X: Not currently used,
- Bit-Y: Primary power source has failed.

Bit-Z: Low battery alarm

Any of the CNI2e's input lines can be configured as alarm inputs, and those alarms can be configured to trigger a call into the host system. If any alarm input goes active an "ALARM TRIGGER" entry will be made in the Audit Trail and Item-108 will be set to a true condition. In addition the very first 5 inputs that are configured as ALARM inputs will set unique bits in the T&A2 or T&A records.

NOTE

Some data collection systems may have different descriptions for some of the alarm bits.
In many cases these descriptions can be changed.

“FIRST-TIME” ITEM CODE DEFAULT VALUES

If the CNI2e has never been configured as a *Pulse Accumulator* or *Mini-Max* it will default some Item Codes to specific values. After the first access, these values will not be changed by the CNI2e again. However, if you reconfigure the CNI2e to be a Metrotek SIP and then reconfigure it back to a *Pulse Accumulator* or *Mini-Max*, these items will return to their default values.

ITEM CODE	DESCRIPTION	DEFAULT VALUE
NONE	Instrument Access code	33333
44	Channel-1 Fixed Factor Value	1.0
90	Channel-1 Fixed Factor Volume Units	7 (CF x 100)
92	Channel-1 Accumulated Volume Units	7 (CF x 100)
98	Channel-1 Input Pulse Value	3(CF x 100)
114	Channel-1 Input Pulse Scaling Factor	1.0
139	Serial Access / Protected Items	0 (full read/write access)
141	Channel-1 Energy Units	0
142	Channel-1 Gas Energy Value	1.0
200	Site ID Part-1	12345678
201	Site ID Part-2	00999999
205	Start of gas day	09:00:00
262	Date Format	0 (MM/DD/YY)
336	Call Retry Performed By	3 (the CNI2e)
405	Site ID Delay Time	0
440	Channel-2 Fixed Factor Value	1.0
457	Channel-2 Fixed Factor Volume Units	7 (CF x 100)
458	Channel-2 Accumulated Volume Units	7 (CF x 100)
912	Channel-2 Input Pulse Value	3 (CF x 100)
913	Channel-2 Input Pulse Scaling Factor	1.0

“First-Time” Item Code Default Values

RESET ITEM CODE DEFAULT VALUES

Any time the CNI2e is reset it will default some Item Codes to specific values.

ITEM CODE	DESCRIPTION	DEFAULT VALUE
49	Low Battery Voltage alarm point (Can only be changed by MP32)	As programmed by MP32.
50	Shutdown voltage limit	3.3 (cannot be changed)
122	Firmware version.	"2.82" for Mini-Max "3.13" for Pulse Accumulator
127	Device Type	"4" for Mini Max "8" for Pulse Accumulator
171, 172	Communications timeout values	25 seconds
202	Time-tagged interval (Can only be changed by MP32)	As programmed by MP32.
221	Daily Corrected Volume Alarm Limit	99999999
229, 230, 231, 232, 233, 234, 258, 259, 260, 261	Audit Trail Item Codes (which items to store in the Audit trail)	255 (not used) Only time stamps and alarm status will be stored in the Audit trail.
333	Call-in Trigger	If the "Originate Calls" box is checked in MP32 then the CNI2e will always be allowed to make scheduled calls and. Item-333 will be set to "2". The CNI2e will also be allowed to make alarm call-ins if any alarm input is configured to do so and the "Originate Calls" box is checked. In this case Item-333 will be set to "3"
339	Scheduled Call-in Phone Number or IP Address	As programmed by MP32.
481	Maximum Audit Trail Record Size	See discussion about Audit Trail Size

Reset Item Code Default Values

485	Call-out Stop Time	As programmed by MP32. See the discussion on “Server Mode Item Codes” for more information.
487	Call-in Keep Alive Time	As programmed by MP32. See the discussion on “Server Mode Item Codes” for more information.
488	Call-out Repeat Interval	0
489	Call-out Keep Alive Time	As programmed by MP32. See the discussion on “Server Mode Item Codes” for more information.
490	Call-out Start Time	As programmed by MP32. See the discussion on “Server Mode Item Codes” for more information.
493	Alarm Call-in Phone Number or IP Address	As programmed by MP32.
495	Primary retry interval	As programmed by MP32
496	Secondary retry interval	As programmed by MP32 but converted to minutes.
497	Primary retry count	As programmed by MP32

Reset Item Code Default Values (continued)

PROGRAMMING THE ITEM CODES

Local Programming

Local programming of the Item Codes requires a PC with the Mercury Masterlink® software and at least one RS-232 (serial) or USB port. If using a USB port you will need a USB-to-serial adapter. In either case you will need a serial cable that can be connected to the TB2 terminal block on the CNI2e board. The cable only needs three signals: Transmit Data (TXD), Receive Data (RXD) and common. On the CNI2e board the TXD line refers to data being transmitted to the computer, and RXD is data being received from the computer.

Prior to starting you should program the CNI2e's serial port for a bit rate that is supported by Masterlink®. The other parameters should be set to 8-bit, no parity, one stop bit and no handshaking. These parameters need to be programmed using the MP32 program and programming cable.

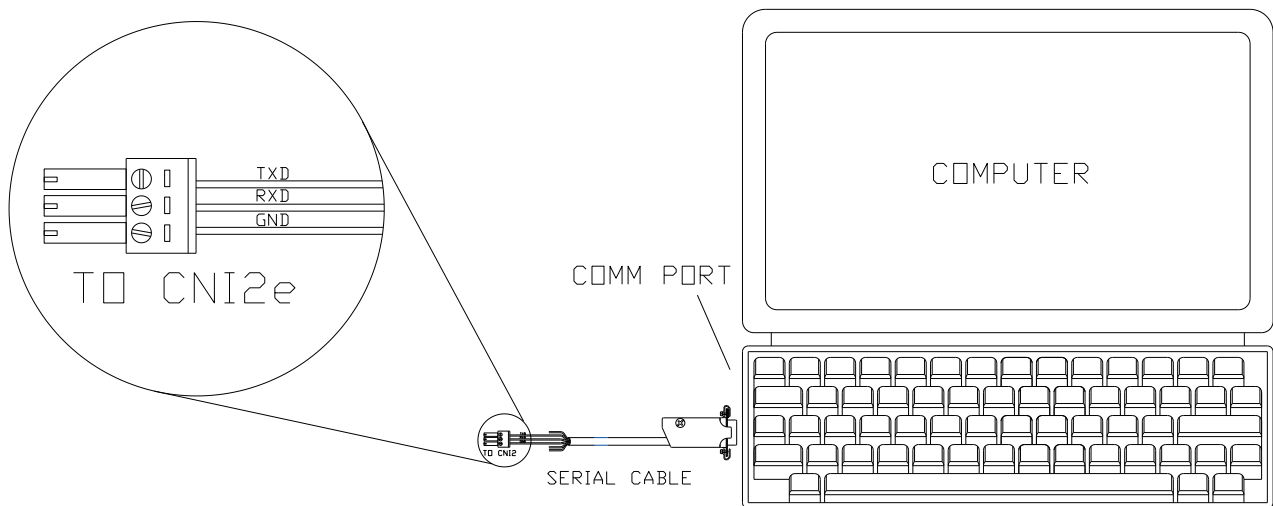

Serial Connection to the CNI2e

Remote Programming

The Item Codes can be changed remotely using Masterlink® software. However Masterlink® can only call out to the CNI2e, so the CNI2e must be able to accept connection requests as a Server. See the previous section about [Server Mode](#).

TRANSPARENT MODEM OPERATION

At the beginning of a call the CNI2e will attempt to communicate with the data collection system using Mercury protocol. If after a period of time there is no recognizable response from the system, and if the “*Allow Transparent*” box is checked in MP32 (see next screenshot), the CNI2e will establish a transparent communications link between the device attached to its serial port and the host system.

Here’s an example of how this might be used. Let’s say the CNI2e is counting pulses from its UMB index and its serial port is connected to a digital camera. The CNI2e will normally call into PowerSpring® or MV90® to report its UMB count information. The data collection system does not know that there is a camera at the site and wouldn’t know how to communicate with it anyway.

Now another application program (not PowerSpring® or MV90® or AutoSol®) wants to capture an image of the site where the CNI2e is located. After the CNI2e connects and does not receive a recognizable Mercury response it will establish a connection to the camera. At this point the application program can now communicate directly with the camera and will close the connection when finished.

The screenshot shows the configuration interface for the CNI2e device, specifically the 'Serial Port Configuration' tab. The 'Operating Mode' section is highlighted with a red oval, showing the 'Allow Transparent' checkbox checked. Other visible settings include:

- Applications: Mercury Pulse Accumulator
- Over-the-air Capabilities: Both Allowed
- Low Battery Alarm: 2.5 Volts
- Immediate call on low-battery condition: checked
- Sample Rates: Lines 1,2,9,10,11,12 (25 /sec); Lines 3,4,5,6,7,8 (0 /sec)
- Queue Size: 32K (selected), 60K
- Queue Full Alarm Point: 75 %
- When answering, if no port select after 0 seconds, route to Port 1

Enabling Transparent Modem Operation

The time it takes to establish the transparent connection might be 50 seconds or more. There is an Item Codes that affects this delay period.

- 1) If the CNI2e is originating the call into the host system it sends a particular message to the host and must wait up to 20 seconds to receive a response from the host system. This is a fixed time period that cannot be changed.
- 2) Whether calling in to the host system or answering a call from the host system, the CNI2e must wait for a particular message from the host system. The amount of time to wait is defined by Item-171. The default value is 25 seconds but you can make this shorter. Do not make this shorter than 10 seconds otherwise latency delays in the cellular network may cause a call to terminate early.

If the CNI2e has not received a recognizable response from the system the Transparent Mode will be entered.

For more information on Transparent Modem operation see the section entitled "[Allow Transparent Mode](#)".

POWER PRESERVATION MODE

“Power Preservation Mode” becomes important when the CNI2e has a primary power source such as an ac-to-dc power adapter, and also a backup power source such as a battery. If ac power is lost the backup battery will allow the CNI2e to continue to count pulses, monitor alarms, keep time, etc. However the battery may not be able to support full-time radio operations for very long.

“Power Preservation Mode” allows the CNI2e to temporarily suspend full-time radio operations in favor of preserving pulse-counting and time-keeping operations.

NOTE

The CNI2e always draws power from the highest voltage source. Therefore the primary power source should always be a higher voltage than the backup supply.

EXAMPLE

The CNI2e has been configured as a data logger and to respond to SMS (text) messages as a paging mechanism. This requires the radio to be powered up at all times to receive those messages. The CNI2e is connected to a 12Vdc power adapter, and also a small 6.5Vdc lithium backup battery that can only support two full hours of continuous radio operations.

The ac power grid goes down for 4 hours.

Without “Power Preservation Mode” the CNI2e would continue as though nothing had happened. The lithium battery dies after 2 hours and all pulse and time information is lost.

With “Power Preservation Mode” the radio is powered down during the time that ac power is lost. After ac power is restored the radio is turned back on and normal operation resumes. There is little impact to the lithium backup battery and no data is lost. There is however a 4-hour window in which the CNI2e cannot be paged.

Configuring the CNI2e-C for Power Preservation Mode

If you wish to use “Power Preservation Mode” on the CNI2e-C then **remove** the jumper shown in the next figure.

If this jumper is not removed the CNI2e-C will still report the loss and/or restoration of power, but will not do anything special to conserve power. In other words, if the radio was powered-up full time before the power failure occurred, it will remain powered up during the power failure.

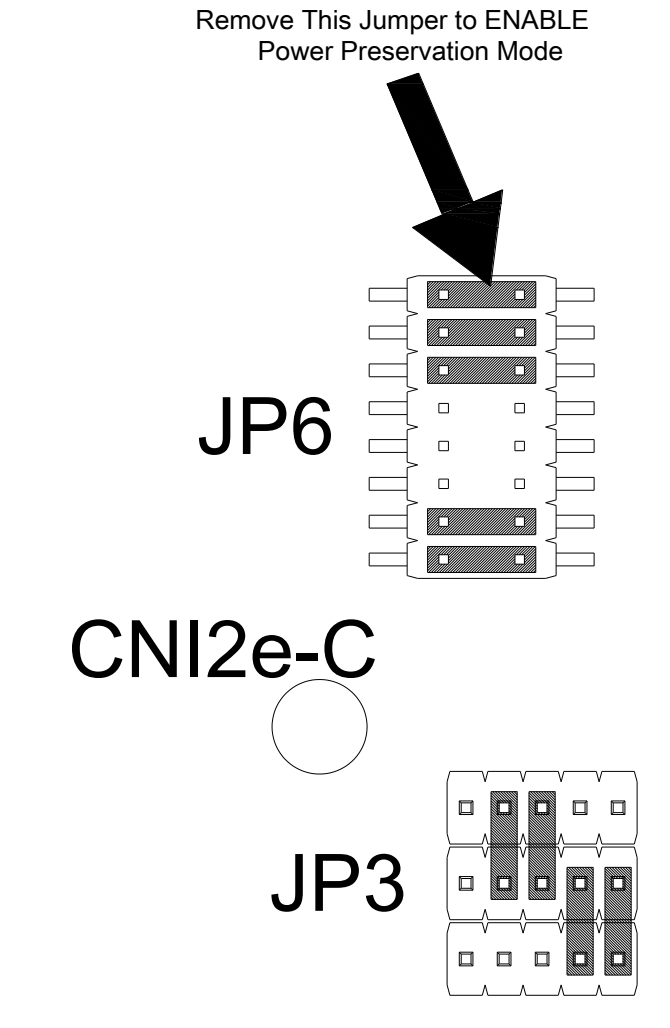

Power Preservation Mode Jumper on CNI2e-C

Configuring the CNI2e-H for Power Preservation Mode

If you wish to use “Power Preservation Mode” on the CNI2e-H then **remove** the jumper shown in the next figure.

If this jumper is not removed the CNI2e-H will still report the loss and/or restoration of power, but will not do anything special to conserve power. In other words, if the radio was powered-up full time before the power failure occurred, it will remain powered up during the power failure.

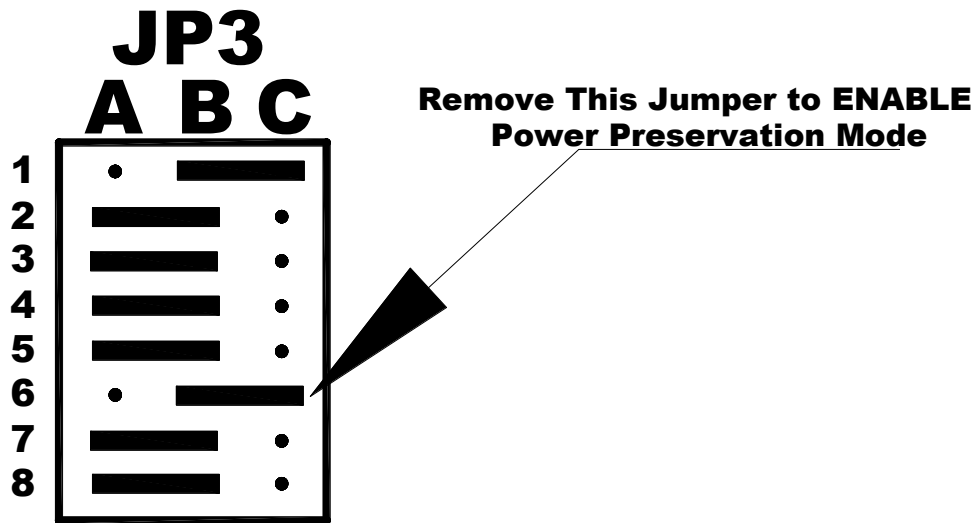

Power Preservation Mode Jumper on CNI2e-H

There are several ways to trigger “Power Preservation Mode”.

TRIGGERING POWER PRESERVATION MODE WITH THE LOW-BATTERY ALARM SET POINT

See a previous section of this manual about how the [low-battery alarm point](#) is processed and reported. In this case we are going to use the Low-Battery Alarm level to detect the loss of the primary power source.

We are going to set the low-battery alarm point to a value somewhere between the normal voltage of the primary power source and that of the backup battery. For instance if the primary source is 12V and the backup is a 6.5V we would want to set the Low Battery Alarm point to about 8.0V. When primary power fails the drop in voltage will be detected and will trigger “Power Preservation Mode”.

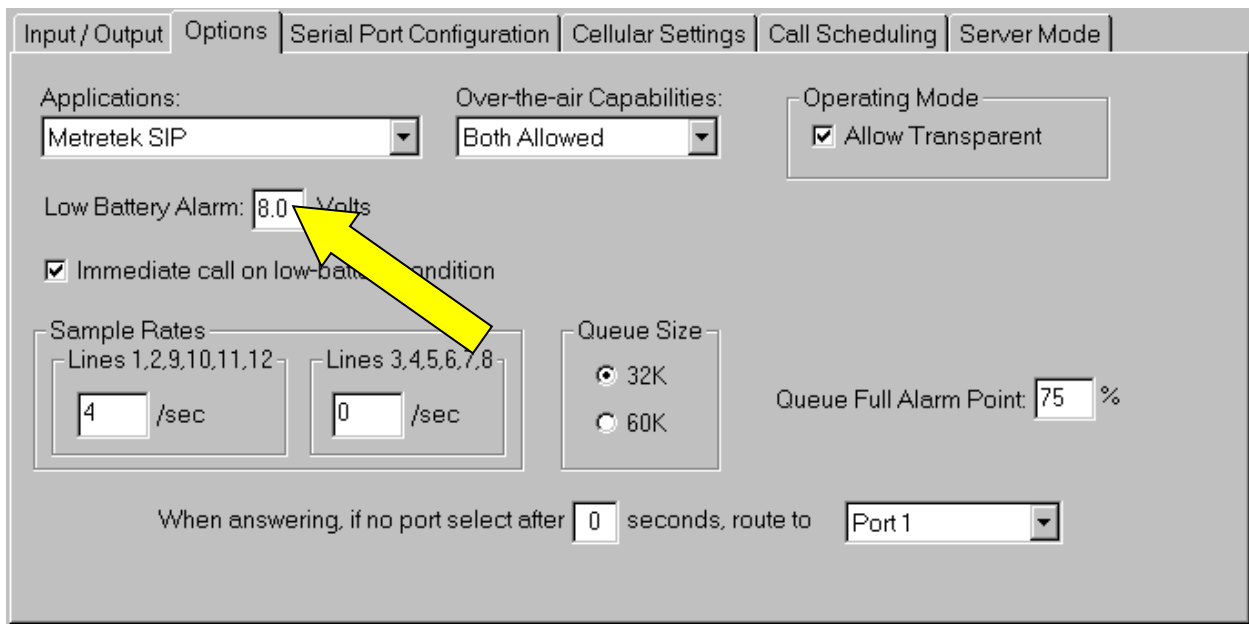

The screenshot shows a configuration window with several tabs: Input / Output, Options, Serial Port Configuration, Cellular Settings, Call Scheduling, and Server Mode. The 'Options' tab is active. It contains the following settings:

- Applications: Metretek SIP
- Over-the-air Capabilities: Both Allowed
- Operating Mode: Allow Transparent
- Low Battery Alarm: 8.0 Volts (highlighted with a yellow arrow)
- Immediate call on low-battery condition
- Sample Rates:
 - Lines 1,2,9,10,11,12: 4 /sec
 - Lines 3,4,5,6,7,8: 0 /sec
- Queue Size: 32K, 60K
- Queue Full Alarm Point: 75 %
- When answering, if no port select after 0 seconds, route to: Port 1

Low-Battery Alarm Point

Here is what happens when “Power Preservation Mode” is triggered by a low-battery condition:

NOTE

A low-battery condition must exist for 2 minutes before Power Preservation Mode” is started.

The low-battery condition must cease for 2 minutes before Power Preservation Mode” is ended.

- If the CNI2e is configured to listen for voice or SMS pages, those modes are temporarily suspended.
- If the CNI2e is currently in Server Mode (connected to the Internet waiting for a connection request), the connection is terminated and Server Mode is temporarily suspended.

-
- If the CNI2e is configured to “*Originate Connections*” and make an “*Immediate Call on Low-Battery Condition*” then the CNI2e will attempt a call to report the condition. If it is unsuccessful it will follow the normal retry strategy until the call is successful. If the CNI2e had been configured as a Metretek SIP or an InvisiConnect device this will be reported as a “LOW BATTERY” alarm. If the CNI2e is configured as a Mercury PA or Mini-Max device this will be reported as a “Vbat LOW” alarm in the audit trail.
 - The CNI2e will power down the radio, the serial port and LEDs.
 - The CNI2e will continue to monitor all alarm inputs and will continue to count pulses.
 - The CNI2e will continue to react to commands from the serial port.
 - If the CNI2e is configured to “*Originate Connections*” it will still attempt calls that are triggered by alarm events, calls that are scheduled or calls that are triggered via commands from the serial port.

Once the primary power has been restored for greater than 2 minutes the CNI2e will resume normal operation.

TRIGGERING POWER PRESERVATION MODE WITH A HARDWARE INPUT

This method uses one of the CNI2e’s input lines to signal that primary power has failed. This signal would be generated by the power source itself. As with any other type of input this signal must be a dry contact or open-collector type of output. You can choose to use a normally-open (Form-A) or normally-closed (Form-B) device.

The *Debounce Count* setting can be used as a way to ignore short-term (“brownout”) power failures. This will be discussed momentarily

In the first example an ac-to-dc adapter with a built-in backup battery also generates a signal when ac power has been lost. In this example this is a Form-A switch (relay or optical sensor) that closes when ac power is lost. This signal is connected to the J11 connector on the CNI2e-C board.

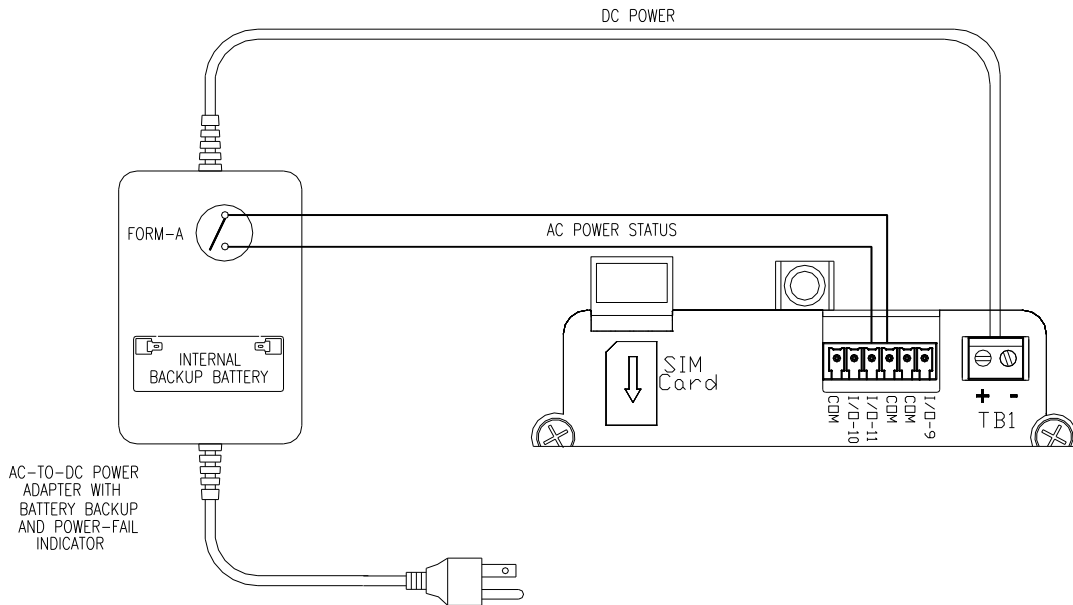

Hardware Trigger Example #1

The 2nd example is a solar-powered system. Power is always provided by the lead-acid battery. But there may be conditions such as cloud or snow cover which may prevent the solar panel from maintaining an adequate charge on the battery. In this case a low-battery signal is provided by the solar regulator, and the CNI2e enters "Power Preservation Mode" until conditions improve.

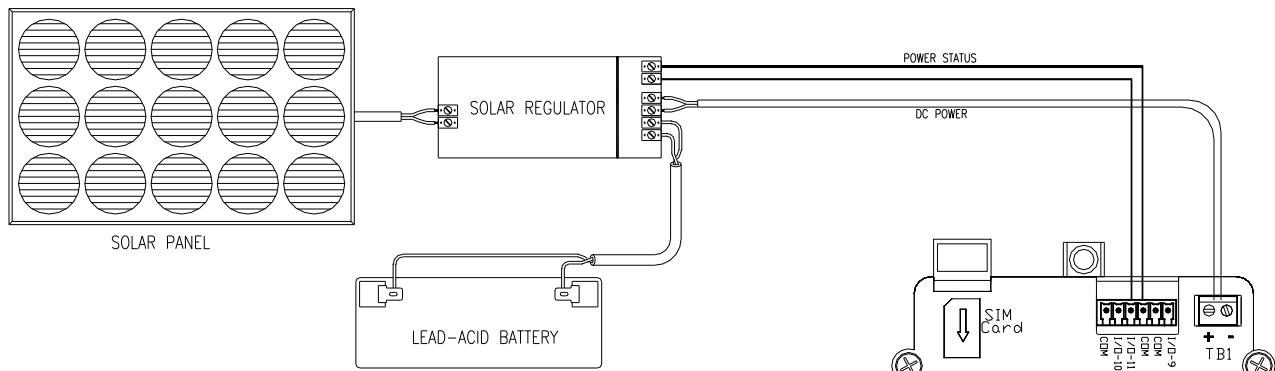

Hardware Trigger Example #2

Configuring Metretek SIP or InvisiConnect Devices

When the CNI2e is configured as a Metretek SIP or an InvisiConnect device it will report a power failure as an “**AC-OFF**” alarm to the data collection system (PowerSpring® or InvisiConnect® or MV90®). Likewise when power is restored an “**AC-ON**” alarm is reported. The CNI2e can be configured to report the condition immediately or wait to report it on the next scheduled call.

For legacy purposes the CNI2e expects the power-fail input to be connected “Line-11”. This input must be configured as an *ALARM INPUT*. The next screen shot shows the proper settings.

Line #	Description
Line 1	Pulse Input-1
Line 2	Pulse Input-2
Line 3	Not Used-3
Line 4	Not Used-4
Line 5	Not Used-5
Line 6	Not Used-6
Line 7	Not Used-7
Line 8	Not Used-8
Line 9	Call Switch
Line 10	Tamper Alarm
Line 11	Power Failure
Line 12	Power Control

Line Type: Alarm Input

Description: Power Failure

Form Type:
 Form A
 Form B
 Form C (Y)
 Form C (Z)

Debounce Cycles: 80

Enable Server Mode on this line
 Input going active when primary power source has failed
 Immediate call on input going active
 Immediate call on input going inactive
 Default alarm to Primary Destination

Destination:
 Phone Number
 IP Address: 65.163.192.84

Port Number: 50466

Destination Modem Baud Rate: 9600

Hardware-Triggered “Power Preservation Mode” Settings for Metretek Devices

Remember, the “*Immediate call on input.....*” settings can be overridden by PowerSpring® or MV90®. If you want the CNI2e to call in immediately on loss or restoration of power, you must check these boxes and enable these alarms in PowerSpring® or MV90®.

The “*Debounce Count*” determines how long the power-fail input must remain active before a “real” power failure event is recognized. It also determines when the event has ended. There is some information about “[debouncing](#)” near the end of this document.

Here’s an example:

The sample rate for this line is set for 4 samples per second. The debounce count is set to 80. This means that the power fail input must be active for 80 consecutive samples in order for the event to be considered “real”. At 4 samples per second this amounts to 20 seconds. Likewise the signal must return to the inactive state for at least 20 seconds to declare that the event has ended.

Configuring Mercury PA or Mini-Max Devices

When the CNI2e is configured as a Mercury PA or Mini-Max device it will report a power failure as Alarm Bit “W” in the T&A2 alarm status in the Audit Trail. The CNI2e can be configured to call in and report the condition immediately or wait to report it on the next scheduled call.

You can select any unused input for this purpose. In the example here we selected Line-11. This input must be configured as a *SPECIAL-PURPOSE INPUT* and the “*Input going active indicates primary power source has failed*” box must be checked.

If you configure more than one input this way, the CNI2e will only recognize the 1st one in the list.

Line #	Description
Line 1	Pulse Input-1
Line 2	Pulse Input-2
Line 3	Not Used-3
Line 4	Not Used-4
Line 5	Not Used-5
Line 6	Not Used-6
Line 7	Not Used-7
Line 8	Not Used-8
Line 9	Call Switch
Line 10	Tamper Alarm
Line 11	Power Failure
Line 12	Power Control

Line Type: Special-Purpose Input

Description: Power Failure

Debounce Cycles: 80

Enable Server Mode on input going active

Input going active indicates primary power source has failed

Immediate call on input going active

Immediate call on input going inactive

Default alarm to Primary Destination

Destination: Phone Number IP Address

Port Number: 50466

Hardware-Triggered “Power Preservation Mode” Settings for Mercury Devices

If you want the CNI2e to call in immediately on loss or restoration of power The “*Immediate call on input.....*” boxes should be checked. Review the section entitled “[Mercury Instruments Emulation](#)” because there are other settings that can keep the unit from calling in immediately.

The “*Debounce Count*” determines how long the power-fail input must remain active before a “real” power failure event is recognized. It also determines when the event has ended. There is some information about “[debouncing](#)” near the end of this document.

Here’s an example:

The sample rate for this line is set for 4 samples per second. The debounce count is set to 80. This means that the power fail input must be active for 80 consecutive samples in order for the event to be considered “real”. At 4 samples per second this amounts to 20 seconds. Likewise the signal must return to the inactive state for at least 20 seconds to declare that the event has ended.

LED STATUS INDICATORS

CALL PROGRESS AND STATUS (CLIENT MODE)

Here is a typical sequence from the time the CNI2e is powered up to the time it completes its first call. The **green** LED is mostly used to indicate the status of the radio and the network whereas the **red** LED indicates the progress of the call. After a reset all future calls start at Step-3.

1. Upon power-up or reset both LEDs turn on for 10-20 seconds:
2. The **red** LED will turn off.
3. The **green** LED will start flashing once per second.
4. The radio is powered up and initialized for communications. If this is successful the **green** LED's flash rate will double.
5. When adequate signal is detected and the radio registers with the network the **green** LED's flash rate will double again if the signal strength is less than 3 bars or will triple for signal strength of 3 bars or more.
6. The unit will start a call sequence.
7. While the **green** LED continues to flash the **red** LED will begin flashing once per second.
8. When the unit has established a data connection to the network the **red** LED's flash rate will double.
9. When the unit has gained access to the internet (packet mode only) the **red** LED's flash rate will double again.
10. When the unit establishes a connection with the data collection system (PowerSpring® or MV90®) both LEDs will light solidly at half intensity. The **red** LED's intensity will increase and decrease (flicker) during the time that the CNI2e is communicating with the host.
11. Once the call has completed both LEDs will return to flashing rapidly.
12. The **red** LED's flash rate will reduce as the data and network connections are terminated.
13. At the end of a successful call both LEDs will light solidly for 3 seconds. If the call was unsuccessful an error code will be displayed twice. A call will be attempted again later using the retry strategy defined by you. See the next section for a list of error codes.
14. The **red** LED turns off.
15. The **green** LED returns to the slowest flash rate as the radio is being powered down.

16. Both LEDs are turned off when the unit enters its “sleep” mode.

NOTE

15 minutes after the unit is powered-up or reset the LEDs will no longer display the call progress. This is done to conserve power.

However if a new call is triggered by the magnetic CALL switch or the TAMPER switch the LEDs will be reactivated for another 15 minutes.

LED ERROR CODES

The two LEDs on the CNI2e board are used to indicate call progress and call status. They are also used to display error codes.

In the event of an error the LEDs will be flashed in a pattern that represents a 2-digit number. The **red** LED represents the first digit while the **green** LED the second digit. For instance, for an error code of “35”, the **red** LED will flash 3 times and then the **green** LED will flash 5 times. An error code is displayed several times to allow the user to observe the pattern.

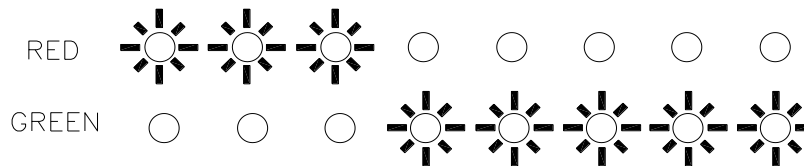

ERROR CODE = "35"

Example of Error Code “35” Display

Error codes are listed on the next few pages.

The last 30 error codes are saved in the CNI2e’s memory and are reported to the data collection system with each call, but only if calling into PowerSpring® or InvisiConnect®. MV90® will not accept this information.

NOTE

15 minutes after the unit is powered-up or reset the LEDs will no longer display error codes. This is done to conserve power. Errors that do occur will still be logged in memory and reported to the data collection system.

NOTE

Any error codes related to a SIM card apply to the CNI2e-H only.

CODE	DESCRIPTION
11	The radio rejected the PIN number that is sometimes required for SIM cards. The PIN number that was programmed into the CNI2e-H may not be needed or may be incorrect. If a PIN number is not required then it should be left blank. PIN numbers are not needed for CNI2e-C.
12	The radio will not register with the cellular network. This could be caused by several things: <ul style="list-style-type: none"> a) Poor signal strength in the area where the unit is located, b) A defective or improperly provisioned SIM card for CNI2e-H units, c) A defective radio, d) A CDMA radio that has not been provisioned correctly (used in the CNI2e-C), e) A radio that does not appear as a valid radio in the cellular provider's database. f) An attempt to register on network that does not have roaming agreements with the primary service provider.
13	No detectable signal from the cellular network. This could be caused by poor signal strength in the area where the unit is located. Otherwise this may be caused by a defective radio or antenna.
14	The connection was unexpectedly terminated by the cellular network. This is not necessarily a hardware problem. Frequent errors may point to marginal signal strength or interference in the area where the unit is located.
15	The selected "Service Type" in MP32 is not currently supported. The choices for the CNI2e-H are either HSPA Only, GSM Only or HSPA & GSM. CDMA is the only valid choice for a CNI2e-C.
16	The radio did not respond properly when reset. This is not necessarily a hardware problem. This can be caused by a nearly depleted battery. It can also occur if a connection is unexpectedly terminated, which may leave the radio in an unpredictable state. It may take one or two cycles to recover from this. Otherwise continuous errors indicate a problem with the radio or possibly an internal power supply circuit.
17	The radio used in the CNI2e-C has not been activated by the cellular service provider. For Verizon radios this error may occur prior to the first over-the-air-activation (OTAA) call. If the error continues then (a) the OTAA phone number entered in MP32® is wrong (b) the carrier does not support OTAA and the radio must be manually activated or (c) the cellular account is provisioned incorrectly or doesn't exist.
18	The radio initialized properly but does not respond to commands. This can be caused by a nearly depleted battery. Otherwise the radio or the SIM card may be defective.
19	The radio does not respond properly to a change in baud rate. This may be a problem with the radio or possibly one of the oscillators on the CNI2e board.

LED Error Codes 11 thru 19

CODE	DESCRIPTION
21	<p>The CNI2e cannot make a connection in CSD (circuit-switched-data) mode. This could be caused if the service provider does not support CSD connections or doesn't offer it at the baud rate specified in MP32. Or the analog modem that is being called is not listening or connecting.</p> <p>By 2014 the only North American service provider that still offered CSD service was Verizon and this is expected to be turned off by end of 2015.</p>
22	<p>The SIM card is defective or cannot be read. Try another SIM card. A SIM card is a memory device and can be damaged by static discharge. If another SIM card also fails then this indicates an electrical problem with the radio or the CNI2e board. SIM cards are only needed for the CNI2e-H.</p>
23	<p>The radio does not respond properly to an echo-off command. This is a problem with the radio.</p>
24	<p>The radio cannot be initialized. This can be caused by a nearly depleted battery. Otherwise the radio or SIM card may be defective.</p>
25	<p>The radio did not return a proper response to a command. This is a problem with the radio or perhaps the SIM card.</p>
26	<p>Packet (Internet) service is not available. This is a problem with the cellular network or with the way the cellular account has been set up.</p>
27	<p>The radio does not respond properly to an SMS command. This is a problem with the radio.</p>
28	<p>For the CNI2e-C, the over-the-air-activation (OTAA) call failed. This is only supported by Verizon units. Aeris units need to be manually provisioned at a Honeywell factory.</p> <p>For the CNI2e-H, this usually indicates that the Access Point Name (APN) is incorrect, or the Password Authentication Protocol (PAP) username or password is incorrect, or not needed.</p>
29	<p>If the CNI2e's serial port is to be connected to an external device (EVC, electric meter, etc.) then the serial port on the CNI2e must be enabled. This is done using MP32 on the "Serial Ports" screen.</p>

LED Error Codes 21 thru 29

CODE	DESCRIPTION
30	Logic supply Vcc is less than 2.8V during light-load conditions. This is generally caused by a nearly depleted battery, a power source that cannot develop a minimum of 4.0V or a power source than cannot provide the proper amount of current.
31	Logic supply Vcc is less than 2.8V during heavy-load conditions. This usually happens when the radio is powered up). This is generally caused by a nearly depleted battery, a power source that cannot develop a minimum of 4.0V or a power source than cannot provide the proper amount of current.
32	The output of the radio's regulator circuit is less than 3.4V. This is generally caused by a nearly depleted battery, a power source that cannot develop a minimum of 4.0V or a power source than cannot provide the proper amount of current. This could be caused by a defective radio or a faulty power circuit on the board.
33	There is a data retention problem with the non-volatile EEPROM memory device.
34	The board has not been calibrated. This error is expected for boards that have not been through the factory calibration procedure. This may also be caused by a defective EEPROM memory device.
35	Problem reading voltages and temperature (A/D converter problem).
36	Hardware-related failure that cannot be repaired in the field.
37	For the CNI2e-C jumper JP6-9/10 is installed. This jumper is used for special applications and should be removed for normal operation. For the CNI2e-H the radio supply voltage is less than 3.4V even though the output of the regulator circuit appears to be operating correctly. This might be caused by a defective radio. Otherwise this is a hardware-related failure that cannot be repaired in the field.
38	There is no primary phone number to dial or no primary IP address to connect to.
39	There is a communications problem with the non-volatile EEPROM memory device.

LED Error Codes 31 thru 39

CODE	DESCRIPTION
41	TCP/IP variables could not be initialized. This is an internal problem with the CNI2e's firmware.
42	<p>Could not establish a point-to-point (PPP) connection with the network. This phase of the connection process essentially identifies the CNI2e and requests access to the network's Internet service. This error could be caused by several things:</p> <ul style="list-style-type: none"> a) The cellular account not being configured for Internet service. b) An incorrect PAP username or password, c) An incorrect APN for CNI2e-H devices. d) The CNI2e has been configured to use "simple internet protocol" (SIP) but the service provider no longer supports SIP or it may have to be added to the cellular account. (NOTE: In order to use Server Mode for the CNI2e-H you <u>must</u> use SIP). e) You are using a Virtual Private Network (VPN) and the cellular account is not set up to accept this device.
43	<p>Could not establish a TCP/IP connection to the destination server. Once the CNI2e is granted access to the network's Internet service it requests a connection to the <i>host system</i>, which could be MV90®, PowerSpring® or InvisiConnect®. This could be caused by several things:</p> <ul style="list-style-type: none"> a) You are using a Virtual Private Network (VPN) and the cellular account is not set up to accept this device. b) The host system is not listening. c) The host system is blocking certain source port numbers, one of which is being used by the CNI2e. d) The CNI2e has been configured with the wrong destination port number or IP address. e) For InvisiConnect® applications there aren't enough open com ports to service the request.
44	Error sending data to the destination server. This is usually caused by an unexpected termination of a connection due to network problems or poor signal conditions. It can also be caused by the software running on the host system.
45	Error receiving data from the destination server. This is usually caused by an unexpected termination of a connection due to network problems or poor signal conditions. It can also be caused by the software running on host system.

LED Error Codes 41 thru 45

CODE	DESCRIPTION
46	Unexpected command from the host system. This might indicate a problem with the way the CNI2e is defined in the host system.
47	No data was exchanged between the CNI2e and the host system for the period of time specified by the "Session Timeout" in MP32.
48	This normally occurs if a device connected to the serial port manipulates the DTR handshake signal to start and/or end a call. For instance if the CNI2e is communicating with the host system but the DTR terminates the call before the session can complete.
49	<p>If the CNI2e is configured to establish Server sessions on a scheduled basis then the CNI2e must contact one of six NIST time servers in order to obtain current time and date information. This error indicates that none of the six NIST servers could be contacted. The CNI2e will try to contact these servers every 30 minutes until a connection can be made.</p> <p>This might be caused by:</p> <ul style="list-style-type: none"> a) The cellular account not being configured for Internet service. b) An incorrect PAP username or password, c) An incorrect APN for CNI2e-H devices. d) The CNI2e has been configured to use "simple internet protocol" (SIP) but the service provider no longer supports SIP or it may have to be added to the cellular account. (NOTE: In order to use Server Mode for the CNI2e-H you <u>must</u> use SIP). e) You are using a Virtual Private Network (VPN) and the cellular account is not set up to allow the CNI2e to call public time server.

LED Error Codes 46 thru 49

CODE	DESCRIPTION
51	Unexpected response from the host system. This might indicate a problem with the way the CNI2e is defined in the host system.
52	The memory address specified in a memory write command from the host system is illegal. This might indicate a problem with the way the CNI2e is defined in the host system.
53	Unexpected message received from the host system to terminate the connection. This can be caused by network problems or poor signal conditions.
54	The message from the host system was too large. This might indicate a problem with the way the CNI2e is defined in the host system.
55	Over-the-air configuration update command contained a memory address outside of the configuration memory area.
56	Unrecognized command from the host system or an inappropriate combination of commands was received. This might indicate a problem with the way the CNI2e is defined in the host system.
57	Although the CNI2e was able to establish a TCP/IP (internet) connection to some server, it failed to validate itself as PowerSpring or InvisiConnect. The CNI2e might be configured with the wrong destination port number or IP address.
58	Message from the host system had an incorrect CRC value. This is usually caused by an unexpected termination of a connection due to network problems or poor signal conditions.
59	The length of the message received from the host system did not match the expected length. This is usually caused by an unexpected termination of a connection due to network problems or poor signal conditions.

LED Error Codes 51 thru 59

CODE	DESCRIPTION
61	This applies to the CNI2e-C only. At the cellular network's request, the CNI2e-C is no longer allowed to power up the radio. This is usually requested for delinquent accounts, defective radios that are disruptive to network services or because the service was terminated.
62	While emulating a Mercury Mini-Max or Pulse Accumulator, an attempt was made to access the CNI2e via its serial port. This access was denied because Item-139 has been configured to prevent this type of access.
63	Not used
64	Not used
65	Not used
66	Not used
67	Not used
68	Not used
69	Not used
71	Configuration memory has not been programmed or is corrupt. Attempt to reload the configuration. Otherwise the FLASH memory in the processor is defective.
72	Not used
73	Could not write into FLASH memory. This is a problem with the CNI2e's processor.
74	Over-the-air firmware update was aborted. This is usually caused by an unexpected termination of a connection due to network problems or poor signal conditions. All firmware or configuration records that were received are discarded.
75	The watchdog timer expired and generated a reset. This could be caused by defective firmware but might also be caused by a defective crystal.
76	The "Applications" selection menu on the Options screen in MP32 is set to a value that is not supported by the CNI2e. For instance on the CNI2e-H the "CDMA" selection is not a valid selection.
77	The voltage supply to the radio exceeds 4.0 Vdc. This indicates a hardware problem that cannot be resolved in the field.
78	Not used
79	Not used
81	For the CNI2e-H there is likely something wrong with the APN (context error)
82	For the CNI2e-H there is likely something wrong with the PAP username or password (context error)
83	For the CNI2e-H the radio is rejecting a request to lock service down to just GSM or HSPA only. Try using the "HSPA & GSM" setting. Otherwise the SIM card may be defective or the CNI2e-H was left in factory test mode.

LED Error Codes 61 thru 83

LEDS AFTER OVER-THE-AIR REPROGRAMMING

If a new operating program (“firmware”) is successfully downloaded over-the-air the call will complete as normal. Then the LEDs will rapidly flash in an alternating pattern for anywhere between 10 – 30 seconds as the CNI2e reprograms itself. At the end of the operation the CNI2e will return to “sleep” mode and both LEDs will turn off.

TECHNICAL INFORMATION

“SAMPLE RATE” EXPLAINED

The CNI2e does not inspect the state of the inputs 100% of the time; otherwise it wouldn't have time to perform any other functions. Rather the CNI2e briefly inspects (“*samples*”) the condition of the lines one or more times each second. You can configure the CNI2e to take as few as one sample per second or as many as 50 samples per second. The 12 lines are divided into two groups, each with its own sampling rate. Lines-1, 2, 9, 10, 11 and 12 are one group. Lines-3 thru 8 are in the other group and are not used.

The sample rate is based on how quickly you expect the inputs to change. Faster sampling rates are used for quickly-changing inputs but results in higher power consumption. Too slow of a sampling rate can lead to errors or missed pulses.

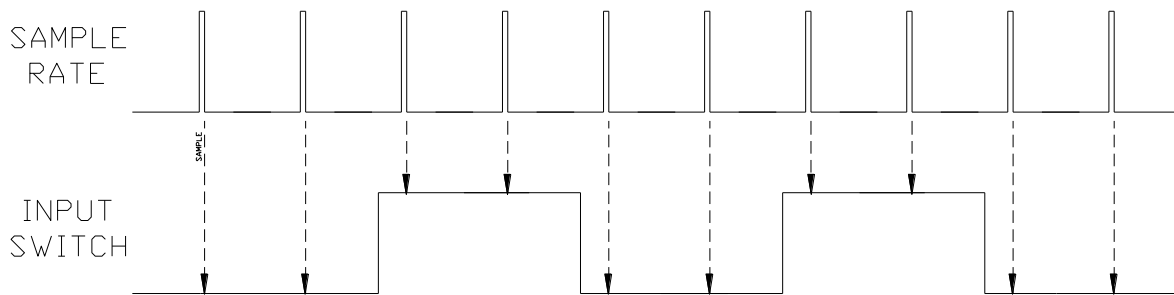

Example of Timed Sampling

“DEBOUNCE” EXPLAINED

What is Switch “Bounce”?

If you strike a hard surface with a stick it is likely to bounce a few times before coming to rest. The same is true for most mechanical switches. As the contacts come together they may “bounce” (open and close a few times), then finally settle in the closed position. This “bouncing” may be falsely interpreted as several events rather than just one. If the CNI2e is counting pulses from this switch it might interpret the bounce as two or three pulses rather than just one. Electronic switches such as transistors do not have this problem.

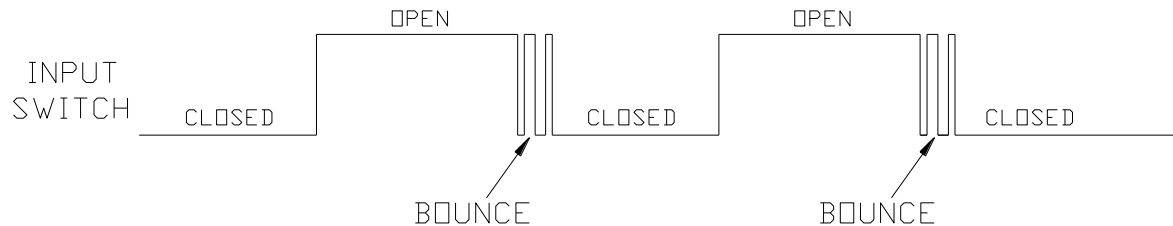

Example of Switch Bounce

What is “Debouncing”?

The process of “debouncing” requires the switch be in the same state over a specific number of samples to be considered “valid”. Therefore the *DEBOUNCE CYCLES* and *SAMPLE RATE* are interrelated. If the input line changes states within this period of time the event is ignored and the debouncing process starts over.

See the next illustration. Suppose an alarm input is sampled 10 times a second and the debounce cycles are set for 4. This means that the input has to be in the same state for 4 consecutive samples (0.4 seconds) to be considered “valid”. If it changes even once during this time the entire process starts over. As seen in the illustration the first and second transitions were ignored because they did not stay in that same state for 4 samples. However the third transition was considered to be a “real” event.

Setting the *DEBOUNCE CYCLES* to 1 will result in the fastest recognition of a change in the switch. As soon as it changes from one state to another it is considered “valid”. But this may also lead to inaccurate results if the switch bounces a lot. This setting is normally used with non-mechanical switches such as transistors because they do not exhibit bounce problems.

The debounce cycle count can be as high as 255. The equation is (debounce ÷ sample rate) seconds. For instance if the sample rate is set to 25 and the debounce is 2, then the input condition will be recognized in (2 ÷ 25) seconds, or 0.08 seconds (80 mS). As an alarm input this means that the signal must be in the active (on) state for at least 80 mS to be considered a real alarm. As a pulse counting input the signal must be in the active (on) state for at least 80 mS and in the inactive (off) state for another 80 mS to be considered a real pulse. This total period of 160 mS translates into a maximum pulse rate of 6.25 pulses per second.

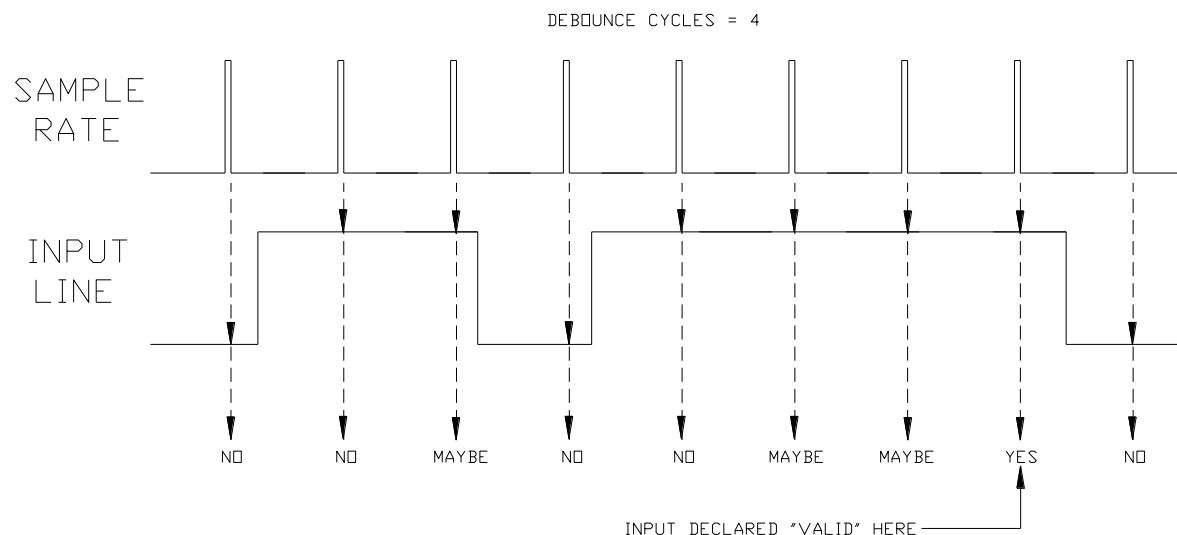

Example of Debouncing Process

FORM-C OPERATION

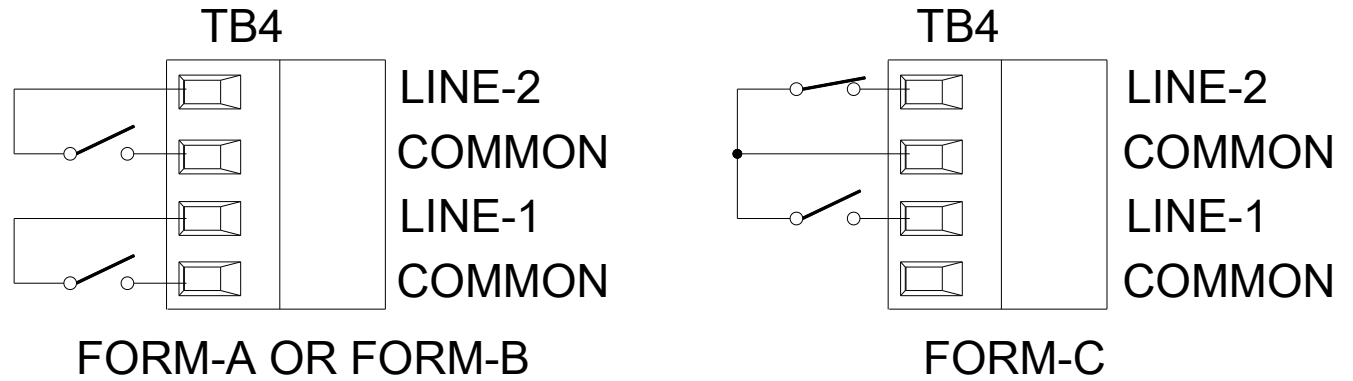

Typical Form-A and Form-C (KYZ) Connections on a CNI2e-C

A Form-C (KYZ) switch is often used so that a defective switch or associated wiring can be detected. In the illustration alarm sensing or pulse counting is performed on the "INPUT-1" connection only. "INPUT-2" is used for fault detection.

The switches should never be open or closed at the same time. If so the CNI2e will report an alarm condition. The next figure shows how a KYZ fault is detected.

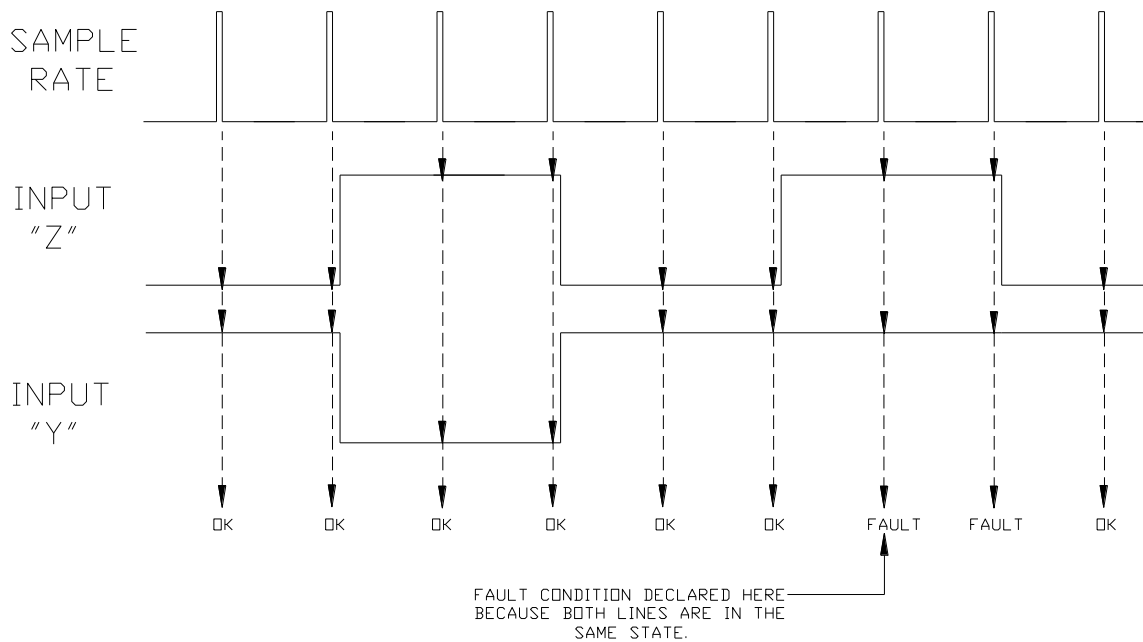

Example of Detection of a Form-C Fault

USING THE OUTPUTS

OUTPUT SIGNAL POLARITIES

The CNI2e's output lines are low-level +3.3V logic signals. Any or all of the six I/O lines can be programmed as outputs. Their polarities are shown in the next illustration which is of a CNI2e-C. The CNI2e-H has equivalent polarities.

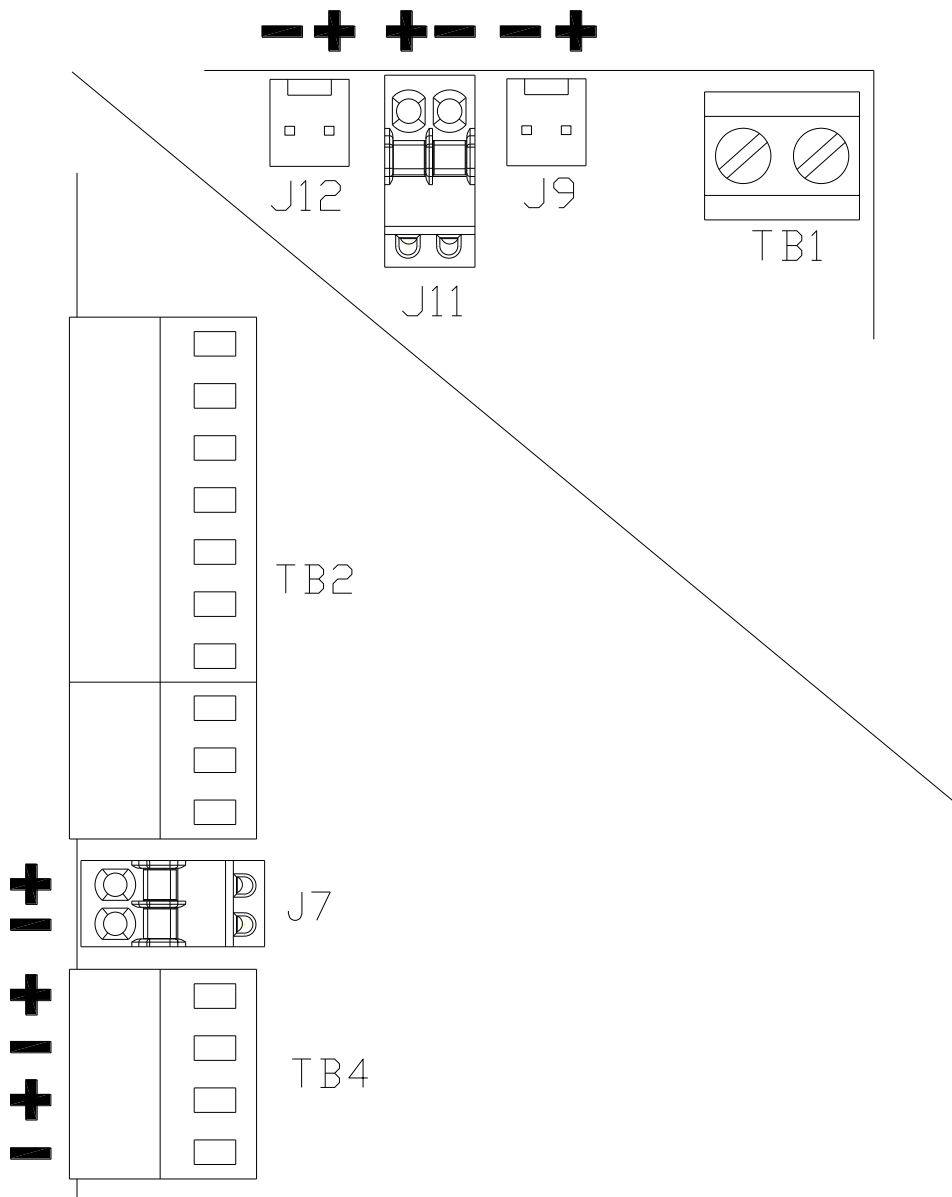

Polarities of the Output Lines (CNI2e-C shown)

OUTPUT-FOLLOWS-INPUT

An output line can be configured to replicate (follow) any of the input lines. This allows other pulse-counting or alarm-sensing equipment to have access to the same signals. For instance the CNI2e may be counting pulses on Line-2 and another piece of equipment located nearby may need to count these pulses too.

OUTPUT-FOLLOWS-INPUT ACCURACY ERRORS

There are some limitations that you should be aware of. The processor samples each input line at a rate defined by the *SAMPLE RATE*. It then sets the output line to the same state with each pass. Input signals that change faster than the sample rate may not be accurately reproduced as illustrated here.

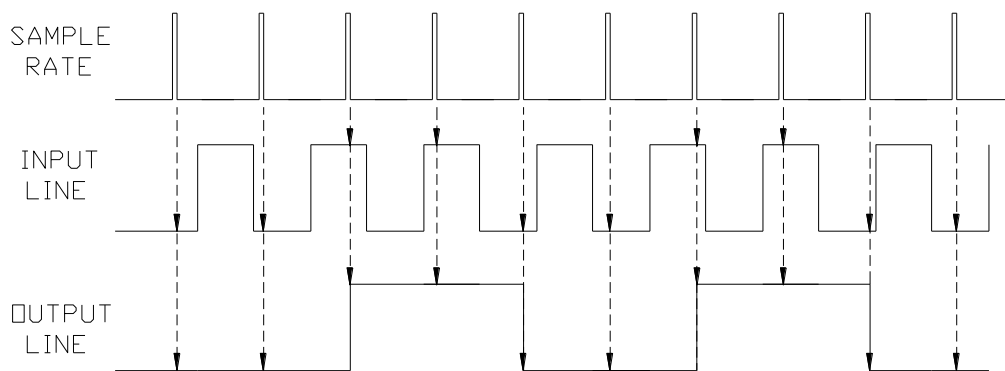

Accuracy Errors Using the “Output-Follows-Input” Feature

OUTPUT-FOLLOWS-INPUT DELAY ERRORS

Also, when an input signal changes state there could be a delay of up to one sample period before the output matches that state, as illustrated here.

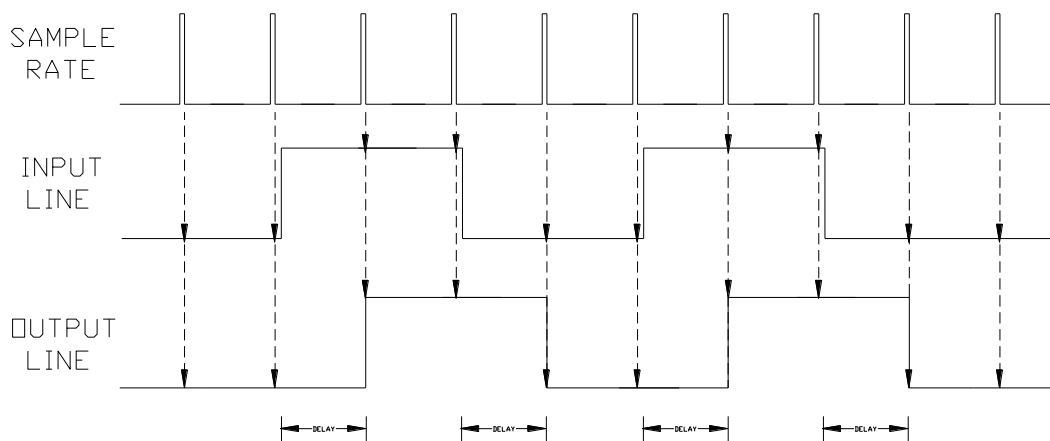

Delay Errors Using “Output-Follows-Input” Feature

CONVERTING A DIGITAL OUTPUT TO DRY CONTACT

The CNI2e's output lines are low-level 3.3V logic signals. Often the equipment that needs to process this signal is expecting a dry-contact (open-collector, open-drain or relay) type of connection that is connected to a higher voltage. (The CNI2e-H offers one dry-contact output that can be connected to wetting voltages as high as 28Vdc.)

One way to convert the signal is by using a solid-state relay (SSR) as shown in the next illustration. We recommend the Allen Bradley 700-SH5FZ24-A device because it only requires a 3V @ 2 mA signal to activate. Other relays may not activate at these levels or may require more current than the CNI2e can supply.

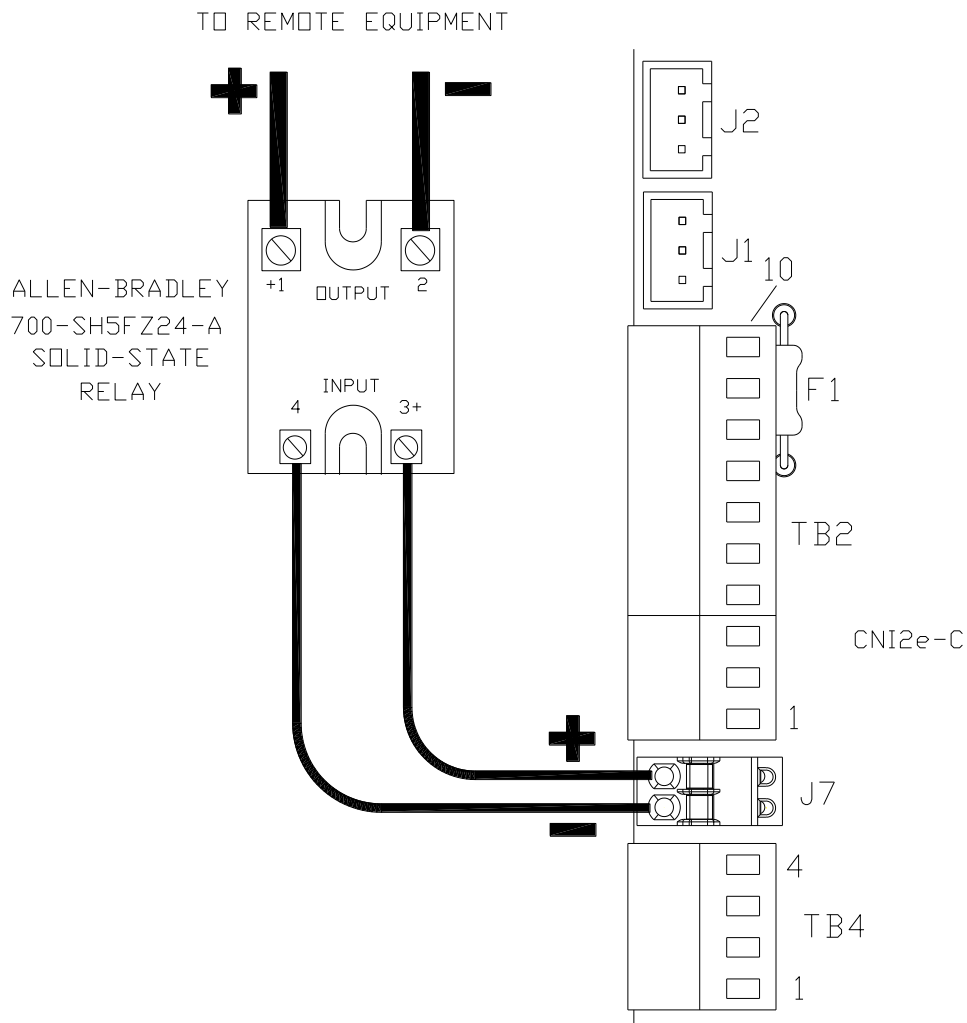

Converting the CNI2e's Logic Output to Dry Contact

In this example the SSR is connected to "Line-12". When the signal goes high it activates the LED within the relay, which is then sensed by the relay's internal optical sensor, which then turns on a semiconductor switch (MOSFET).

NOTE

The use of a solid-state relay may greatly reduce battery life.

One problem with using a solid-state relay or transistor is that the polarity of the output is opposite that of the input. A “high” signal from the CNI2e appears as a low signal on the output of the relay. This may be undesirable if the output has been programmed to follow an input (repeater function). You can use the MP32 program to reverse the polarity of the output so that the output of the relay is a true representation of the input signal.

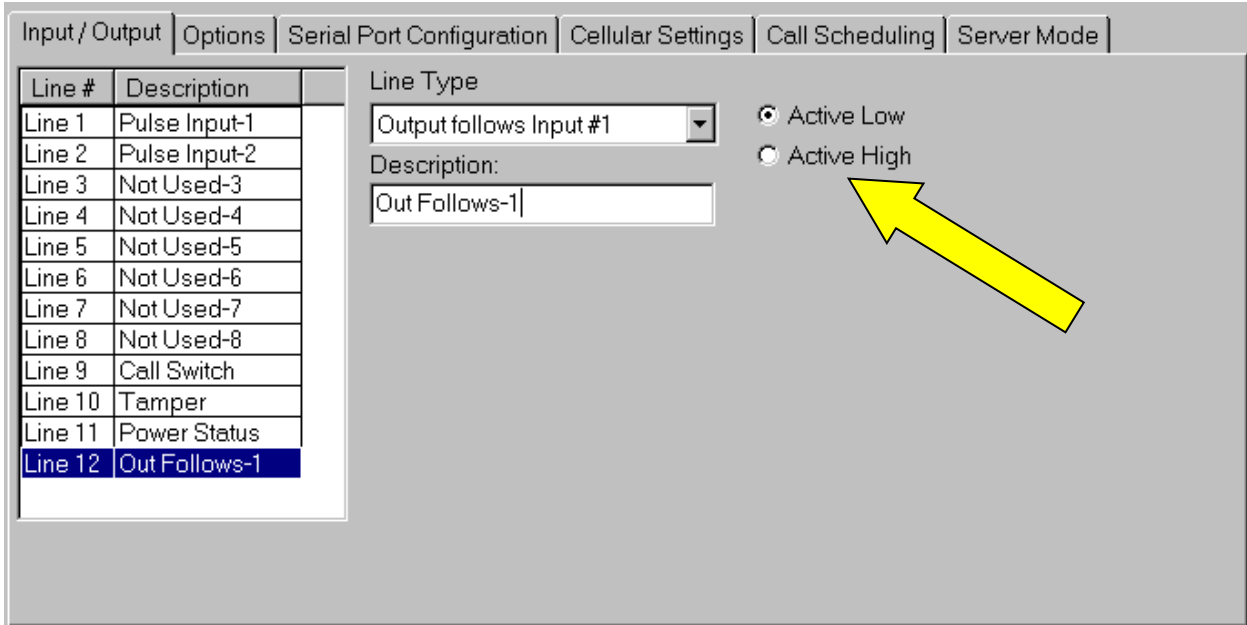

Changing the Polarity of the “Output-Follows-Input” Feature

If you select “**Active Low**” then the CNI2e’s output will have the same polarity as the input. If using a solid-state relay or transistor, its output will be the opposite of the original input.

If you select “**Active High**” then the CNI2e’s output will have the opposite polarity as the input. If using a solid-state relay or transistor, its output will be the same as the original input.

The following illustrations show the connections for the “Line-10”, “Line-11” and “Line-9” on a CNI2e-C.

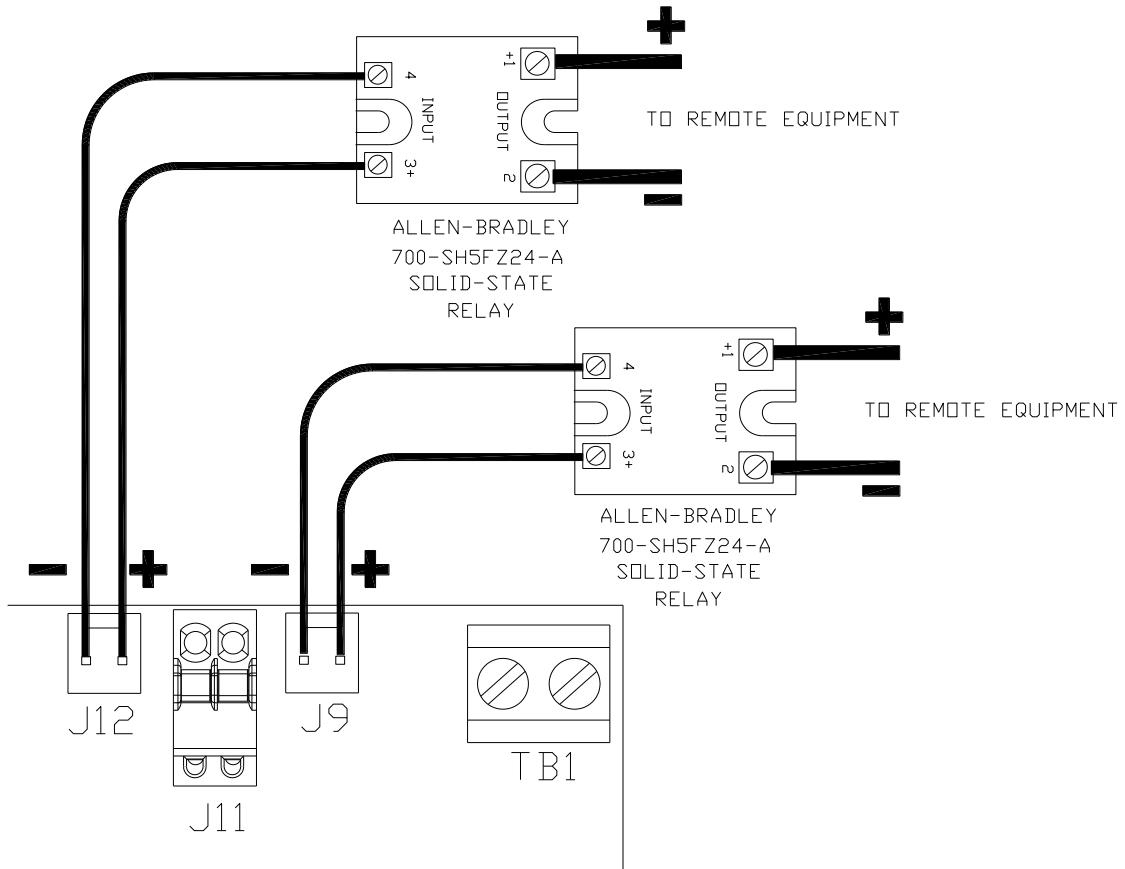

Converting the CNI2e-C’s “J9” or “J12” Output to Dry Contact

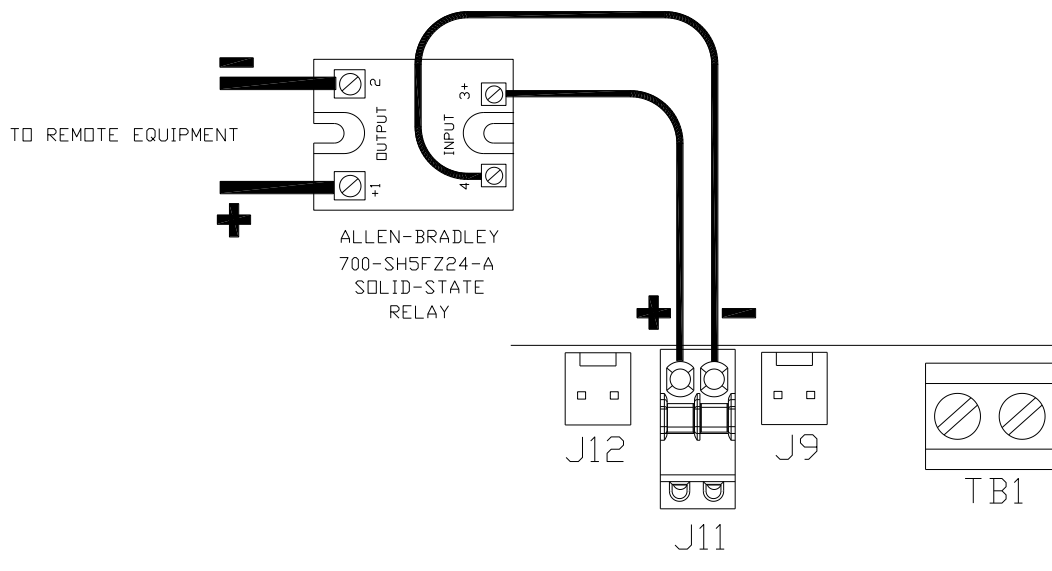

Converting the CNI2e-C’s “J11” Output to Dry Contact

USING THE OPEN-COLLECTOR OUTPUT ON THE CNI2e-H

On the CNI2e-H only Line-12 can be configured to be a push-pull or dry contact (open-collector) output. See the diagram below for the proper jumper settings

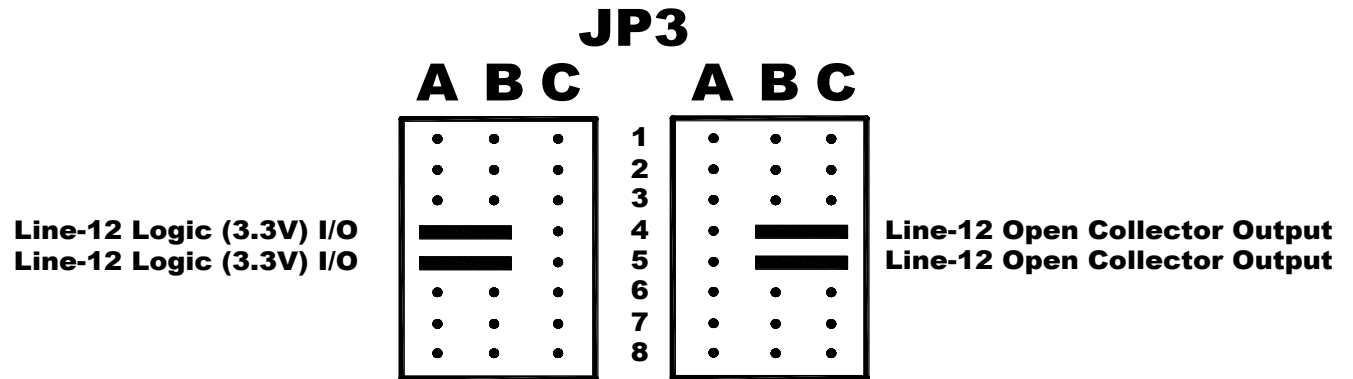

CNI2e-H Line-12 Configuration Jumpers

When configured as a dry contact output the CNI2e-H is optically isolated from the external equipment. Maximum pull-up voltage is 28 Vdc. The output is current-limited by a 1000Ω resistor. Therefore the maximum allowable current is 28 mA (0.028A).

AT MODEM EMULATION MODE

For this discussion the symbol <cr> indicates an ASCII control character called “carriage return” and is represented by a single value (byte) of 13 decimal or 0D hex.

For this discussion the symbol <lf> indicates an ASCII control character called “line feed” and is represented by a single value (byte) of 10 decimal or 0A hex.

NOTE

If the CNI2e will respond to AT modem commands in ALL modes of operation.

If you have a serial device attached to the CNI2e’s serial port it is likely that the device is expecting to communicate with an AT-compatible modem. The acronym “AT” means “attention”. AT modem commands always start with the ASCII characters “AT” or “at” followed by other characters that define specific operations. The final character of a command string is always a carriage return (<cr>).

Upon completion of a command the modem sends back a response in one of two formats, either “terse” or “verbose”. Terse messages (also called “non-verbose” or “numeric”) are often one to two ASCII numbers followed by a <cr>. Verbose messages are readable ASCII messages preceded and followed by a <cr><lf> combination. For example when an incoming call is detected the verbose message will be “<cr><lf>RING<cr><lf>” whereas the terse version is simply “2<cr>”.

These are the typical responses that the CNI will return to the remote device:

Terse Response (Note-1)	Verbose Response (Note-2)	DESCRIPTION
0	OK	Accepted, no error
1	CONNECT	Connected with remote modem
2	RING	Incoming call
3	NO CARRIER	Connection with remote modem is lost
4	ERROR	Command error

Note-1: Terse (non-verbose) responses always followed by one carriage return <cr>.

Note-2: Verbose responses always preceded and followed by one carriage return <cr> and one line feed <lf>.

Typical CNI2e “AT” Responses

The remote device may issue commands that were important to the original modem but not to the CNI2e. In these cases the CNI2e will return a standard response such as “OK” to these commands. Other commands are meaningful and the CNI2e will act upon them. The following is a list of these commands. The CNI2e defaults to certain settings until programmed otherwise.

ATV (response type) Command

ATV, ATV0: This instructs the CNI2e to return “terse” (non-verbose or numeric) result codes starting with this command.

ATV1 (default): This instructs the CNI2e to return “verbose” result codes starting with this command. This is the default setting

NOTE:

An ATV command will override the *Use Non-verbose Result Codes* setting that was programmed by MP32.

ATE (echo) Command

An AT modem can be instructed to immediately return every character it receives. This is called “echoing”. The “ATE” command controls this function. The default is echo OFF.

ATE, ATE0 (default): This instructs the CNI2e to disable echoing starting with the next command.

ATE1: This instructs the CNI2e to enable echoing starting with the next command.

ATH (hangup) Command

ATH, ATH0: Once a connection has been established this instructs the CNI2e to terminate the connection with the central computer. The normal response to this is “NO CARRIER”. If a connection does not exist then the normal response will be “OK”.

ATZ (reset) Command

ATZ, ATZ0: Once a connection has been established this command instructs the CNI2e to terminate the connection with the central computer. The normal response to this is “NO CARRIER”. If a connection does not exist then the normal response will be “OK”.

ATA (answer) Command

ATA: This instructs the CNI2e to answer an incoming call and establish a connection with the central computer. The normal response is a “CONNECT” message if a connection is established or “NO CARRIER” if one could not be established. The CONNECT message can be modified using MP32.

ATD (dial) Command

ATDxxxx, ATDPxxxx, ATDTxxxx: This instructs the CNI2e to establish a connection to the central computer. The “xxxx” portion of this command is the phone number or IP address of the central office. For “ATD” commands with no phone number included, the CNI2e will use the primary destination phone number or IP address that was programmed by MP32.

The normal response is a “CONNECT” message if a connection is established or “NO CARRIER” if one could not be established. The CONNECT message can be modified using MP32.

For CSD calls the “xxxx” portion of the ATD command is the destination phone number followed by a <cr>. Example ATD3215551212<cr> will dial the number 555-12212 in area code 321.

For IP mode the “xxxx” portion of the ATD command is *IP address/Port Number <cr>*. For example ATD192.34.165.29/23267 will connect to IP address 192.34.165.29 on Port #23267.

NOTE

If the CNI2e detects a decimal point (.) or a forward slash (/) in the dial string it will assume this is an IP address and Port #, and not a standard phone number.

+++ (escape) Command

Once the CNI2e has established a connection with the central computer it can no longer respond to AT commands. However AT modems are always looking for an “escape” sequence, which is “+++” preceded and followed by 1 second of quiet time. This will return the CNI2e to command mode and the unit will respond with an “OK” message.

Following this the CNI2e will wait 5 seconds to receive an “ATH” (hangup) command from the device. If the command is received, or 5 seconds elapse, the CNI2e will terminate the connection with the central computer and will return a “NO CARRIER” message to the remote device.

AT Command Chaining

“AT” commands can be grouped together into one string. For example, the command “ATE0V1” commands the CNI2e to turn off echoing and return verbose responses. However “ATA”, “ATH” or “ATD” commands should be sent separately or should be the last command in a chain.

AT+ICLK? (time and date) Command

This command will return time and date information to the serial device. The response will be formatted as follows, including delimiters such as quotation marks (“), forward slash (/) and colon (:):

`<cr><lf>+ICLK: "yy/MM/dd,hh:mm:ss±zz"<cr><lf>`

where:

yy = 2-digit year [00-99], as in 2000-2099]

MM = 2-digit month [01-12]

dd = 2-digit day of month [00-31]

hh = 2-digit hour [00-23]

mm = 2-digit minute [00-59]

ss = 2-digit seconds [00-59]

± = “+” or “-“

zz = time zone offset from GMT(UTC) in ¼ hour increments [-48 to +48]

If the CNI2e does not have a valid time an “ERROR” message will be returned instead.

In order for the CNI2e to provide a valid response it must be given time and date information by some computer system. The CNI2e does not get its time from the cellular network.

Here are some things to consider when using the AT+ICLK? command:

- If the CNI2e receives its time from a computer running MV90®, PowerSpring®, InvisiConnect® or Masterlink® software the CNI2e's time represents the time on the computer system. If the CNI2e is in a different time zone then the "zz" offset will represent the time zone in which the computer is located.
- When configured as a Metretek SIP data logger the time given to the CNI2e does not contain any information about year, month or day. So these values in the response, as well as the time zone offset, will be incorrect.
- When configured as an SMS Modem the CNI2e will respond with an "ERROR" message.
- When configured as an InvisiConnect® device, in order for the CNI2 to receive time and date information from the InvisiConnect® Server, the "Provide Time/Date Updates to Remote Devices" feature must be turned on in the InvisiConnect® software.
- When configured as a Transparent Modem, or if a schedule for Server sessions has been defined, shortly after a power up or reset the CNI2e will attempt to call one of five time servers managed by the United States National Institute of Standards and Technology (NIST). If it is unable to obtain the time it will try again every 30 minutes. Once the time is obtained the CNI2e will attempt to contact a NIST time server every four days to update the clock. See the section of this manual titled "Server Mode" for details.

AT+TOTALS? Command

This command allows the user to see the totalizer values from all pulse-counting channels.

For example for a CNI2e that has been configured to count pulses on Lines 1, 5, 6 and 10 the response will be:

```
<cr><lf>+TOTALS: <cr><lf>
L01=00000000124<cr><lf>
L05=0000009876<cr><lf>
L06=0000000000<cr><lf>
L10=0000000013<cr><lf>
<cr><lf>OK<cr><lf>
```

For a unit that has been configured to count pulses on Line 1 only the response will be:

```
<cr><lf>+TOTALS: <cr><lf>
L01=0000000124<cr><lf>
<cr><lf>OK<cr><lf>
```

Response to AT Commands while in SLEEP Mode

In low-power sleep mode the CNI2e shuts down its serial port components in order to conserve power. However the CNI2e can still detect activity on the received data line (RXD) or the DTR line. A jumper selects which line to respond to. See the [ELECTRICAL ASSEMBLIES](#) section for the location of these jumpers.

NOTE

While in sleep mode the CNI2e will not be able to interpret the very first character that arrives. It is common practice for serial devices to send the same command more than once until it receives a valid response.

The CNI2e should correctly interpret the second command that arrives as long as it arrives within 10 seconds of the first one.

POWERSPRING (DC-2009) DATA COLLECTION SOFTWARE SETUP FOR METRETEK “SIP” MODE

INTRODUCTION

This chapter introduces the fundamental data collection setup parameters needed to start the communications process with the CNI2e when it configured as a Metretek “SIP” and communicating with the PowerSpring data collection system. It does not address reports or database management. Additional training is available from Honeywell, as well as hands-on training options.

SETTING UP THE SIP SERVER FOR PACKET (INTERNET) CONNECTIONS

For Packet (Internet) connections the SIP server acts as an Internet server on your computer and thus must be allowed access to the outside world. An Internet address and port number must be assigned to the SIP server, and these numbers must be programmed into each CNI2e. Your computer systems’ administrator usually assigns the address and port number.

Start the PowerSpring Applications Launcher and select “System Configuration”.

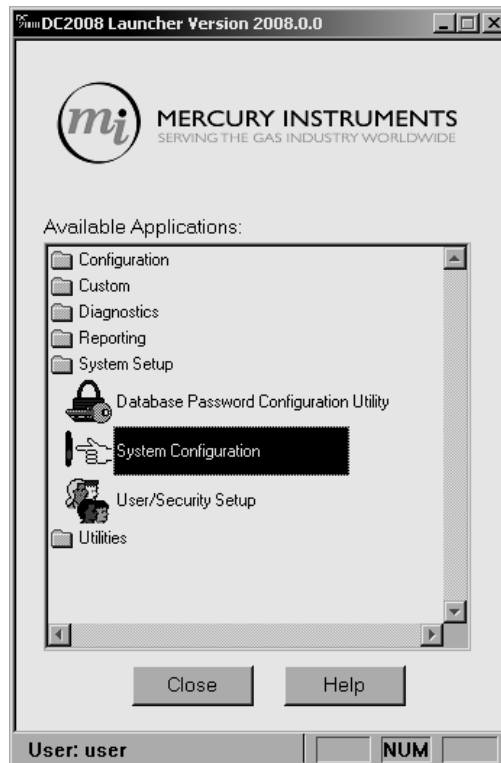

Starting the PowerSpring System Configuration

On the next screen select the Data Collection process. There may be more than one to choose from depending upon the way PowerSpring has been configured.

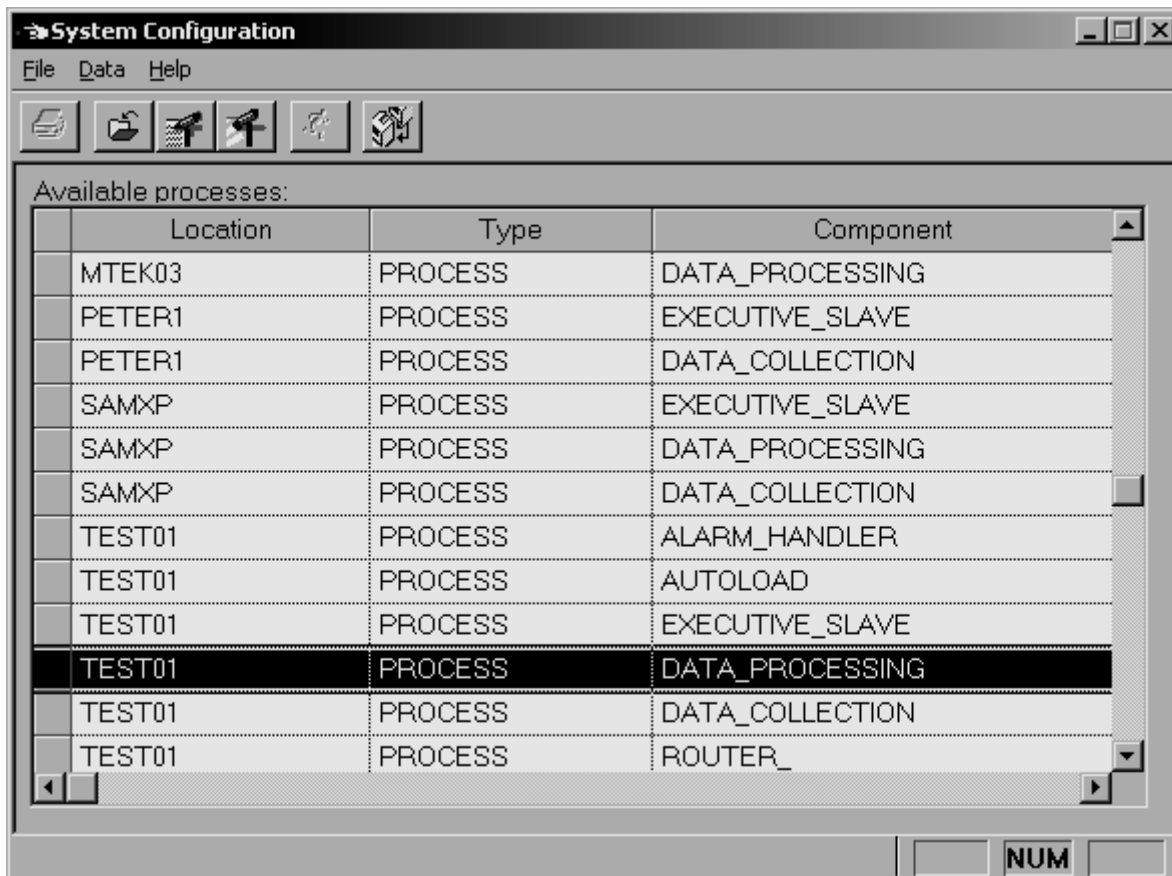

Changing the Data Collection Configuration

On the next screen select the “Internet Ports” tab and select the “Add” button near the bottom of the screen. A smaller selection window will appear. Place a checkmark in the “Enabled” checkbox. Select “SIP Server” for the port type. The port number will be filled in automatically, and must match the port number that was programmed into the CNI2e. The default is 50466. If a different port number is being used then hold down the CTRL key on the keyboard, point to the Port Number box and double click on the port number box. Then enter a new port number.

Enter the Internet address that was assigned to PowerSpring and programmed into the CNI2e. Your computer systems’ administrator usually assigns this address.

PowerSpring has a number of Internet servers for various products. A maximum of 255 connections are allowed at the same time for all servers. For instance if there are already 200 connections allocated for other products, you can only open another 55 connections for the SIP server. If you have 50 devices in the field and only 10 connections allocated, then only 10 devices will be allowed to connect at any one time. The devices can be scheduled to call in at different times during the day to resolve this. The choice of how many to assign depends upon the capabilities of the data collection computer.

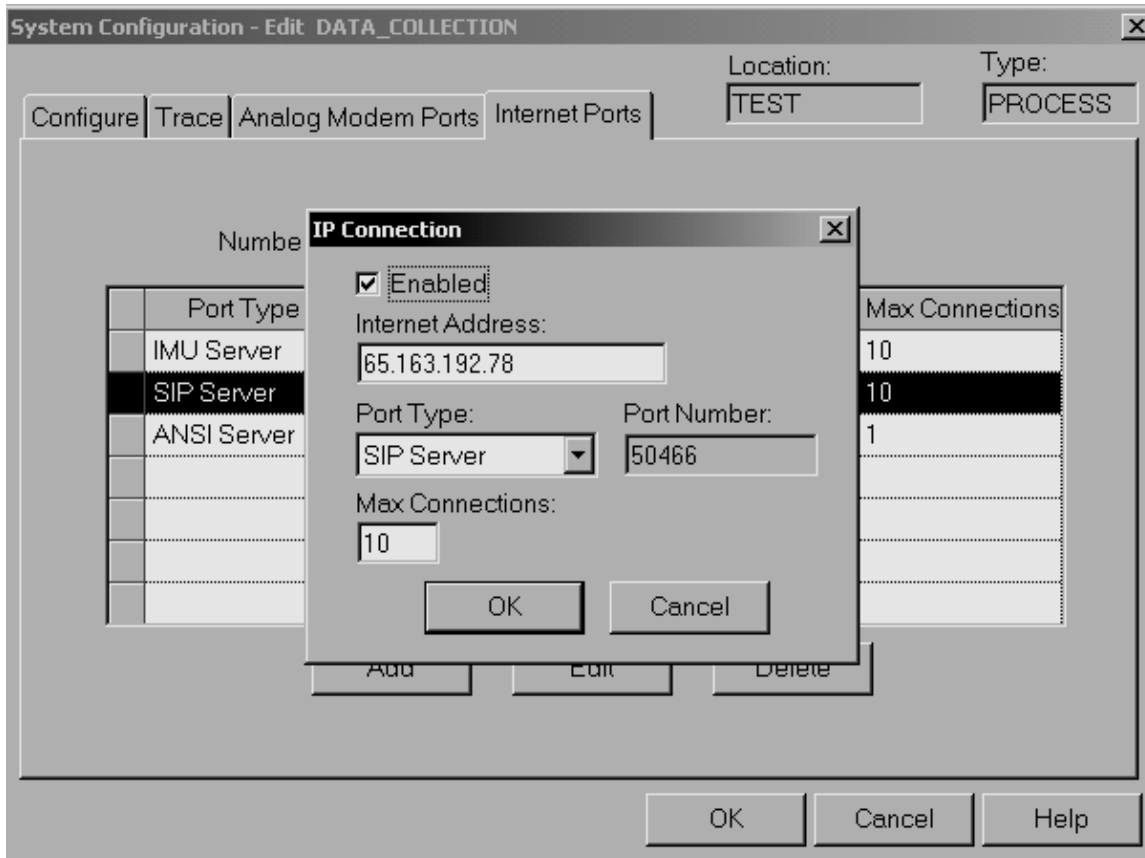

Configuring the SIP Server

SETTING UP POWERSPRING FOR CSD CONNECTIONS

CSD connections are basically the same as two modems communicating over wired phone lines. Start the PowerSpring Applications Launcher and select "System Configuration". On the next screen select the Data Collection process.

On the next screen select the "Analog Modem Ports" tab. Some cellular providers that support CSD calls do not support bit rates below 9600 bps, and the GSM version of the CNI2e does not support anything below 4800 bps. Therefore you will need at least one 9600 bps MODSMOD modem card in the Mercury MODSMOD chassis.

In the example shown below we have configured PowerSpring for a 9600 bps MODSMOD card on Channel-1 using a METRETEK software driver. The baud rate selection box near the bottom of the screen is the bit rate between the computer and the MODSMOD card, not between the MODSMOD and the CNI2e. This rate is determined by a set of jumpers on the MODSMOD card. 19200 bps is the recommended setting.

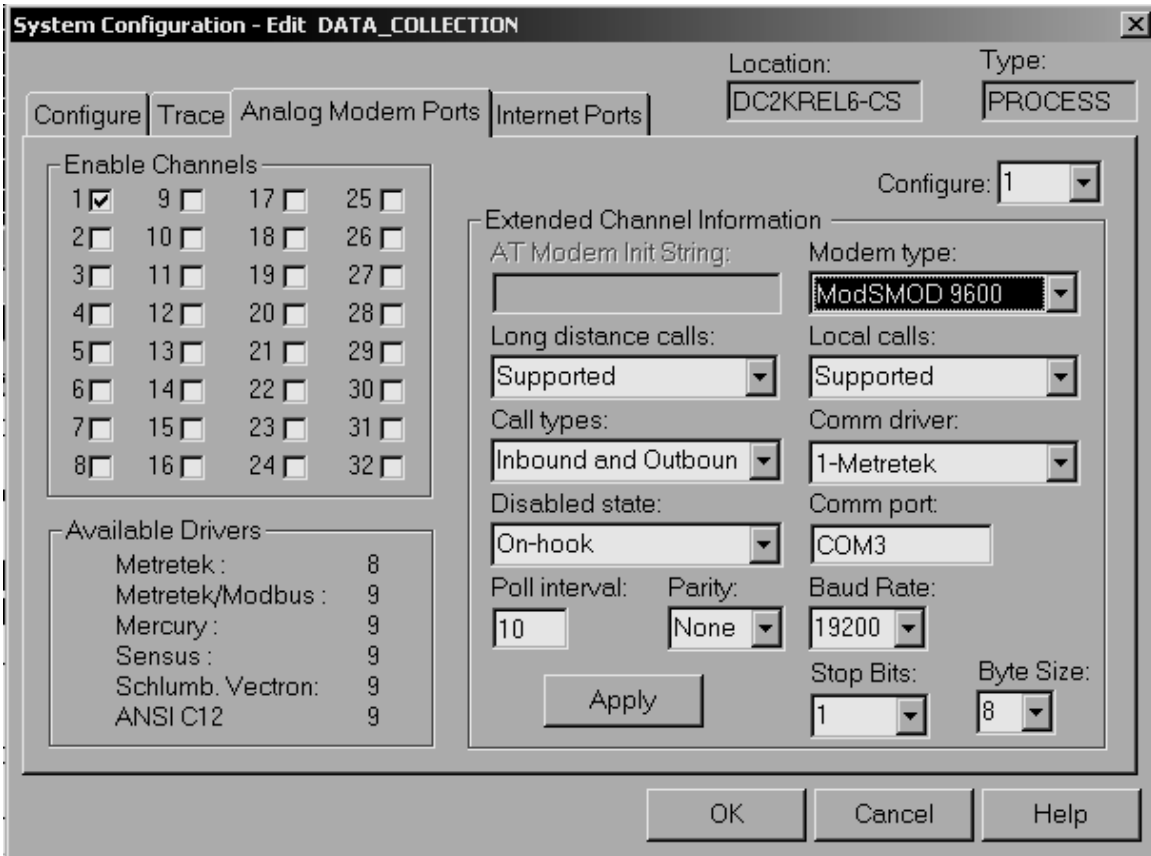

Configuring PowerSpring for CSD Connections

SETTING UP A CALL SCHEDULE

When the CNI2e's are in service you may want them to call in at regular intervals, say once an hour or once a day. You can define a call schedule for one CNI2e, or a group of them by selecting "Call Configuration" from the Applications Launcher.

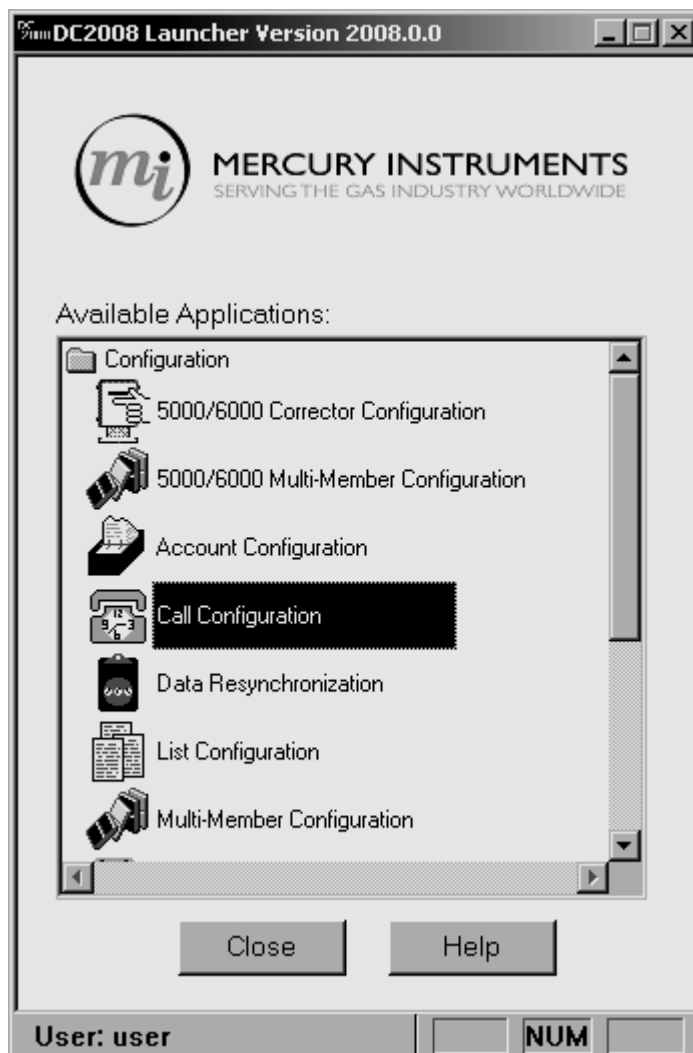

Configuring a Call Schedule

On the next screen select the “Add” button and enter in a text name for the profile.

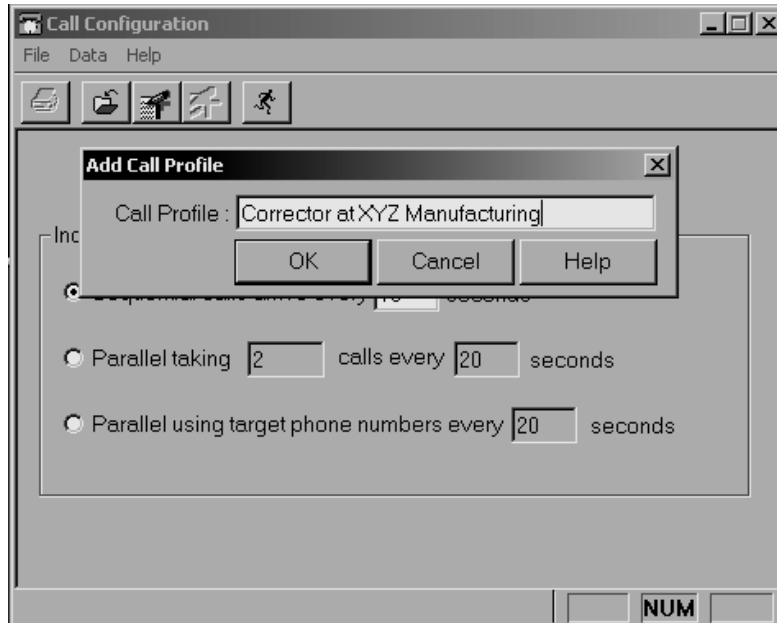

Defining a Call Profile Name

On the final screen you can define the rate at which the devices should call in. In the following figure, the CNI2e will call in at regular 8-hour intervals starting at 14:00:00. This is a Periodic schedule. The CNI2e must make at least one call into the system in order to obtain the first call schedule. Thereafter each time the unit calls in PowerSpring will instruct the CNI2e to call again in 8 hours.

 **NOTE:**

An aggressive call schedule will reduce battery life of CNI2e products that run entirely on battery power.

You can also use the Non-Periodic Call mode to define unusual call profiles. For instance you may want the CNI2e to call in at 8:00 and 12:00 each day. A Honeywell Product Support Specialist can provide assistance in defining these special profiles.

Select the Apply button to make the changes permanent.

Call Configuration Edit Call Profile - Corrector at XYZ Manufacturing

Call Frequency

Non Periodic Call Number of days between calls: 0

Periodic Call Call interval: Hours: 8 Minutes: 0 Seconds: 0

Call Window

Current call windows

Description	Start time
Call window 1	2:00:00 PM

Description: Call window 1

Start time: 14:00:00

Apply

OK Cancel Help

Defining a Call Profile

DEFINING THE CNI2E – MANUAL MODE

Now that you've defined how PowerSpring will communicate with a CNI2e you must define the CNI2e itself. Information in PowerSpring must correlate with the configuration of the CNI2e. The number of data (pulse) inputs and the pulse-counting interval sizes must match exactly.

There are two methods that can be used. The one that will be discussed first allows you to manually define each CNI2e. Later we will describe how this can be done automatically each time a new CNI2e calls in for the first time.

Start the PowerSpring Applications Launcher and select the 'Remote Unit Configuration' application as shown next.

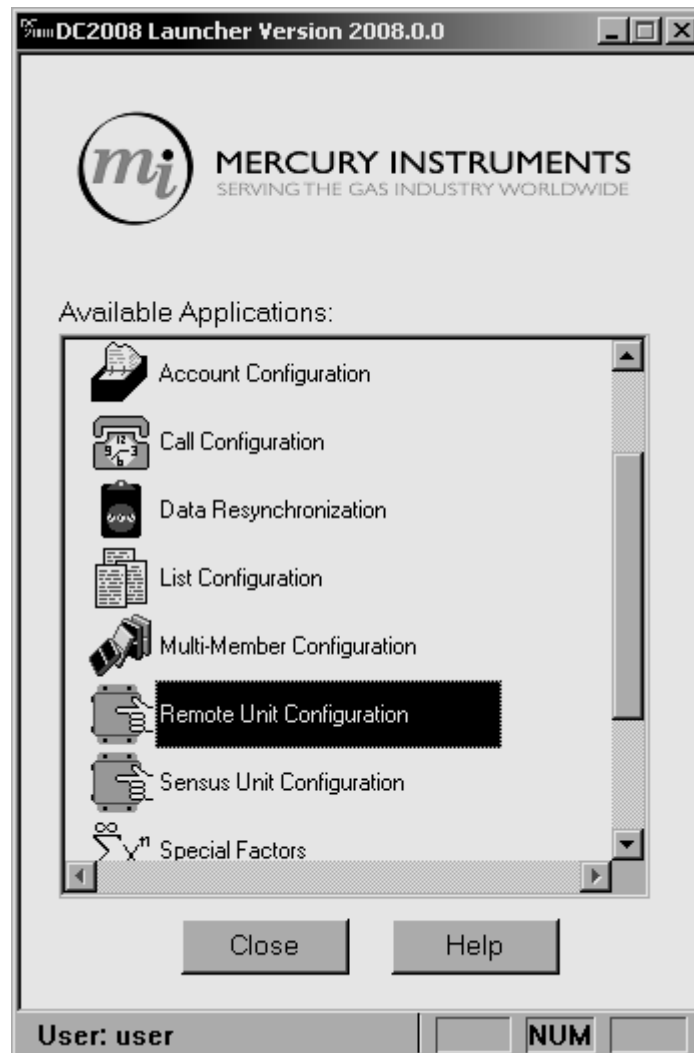

Starting the CNI2e Configuration Process

The next screen will appear. It is not necessary to select a device that's already been defined, simply select the ADD icon 



Remote Unit Selection Screen

On the next screen select "Mercury Types" and OK.

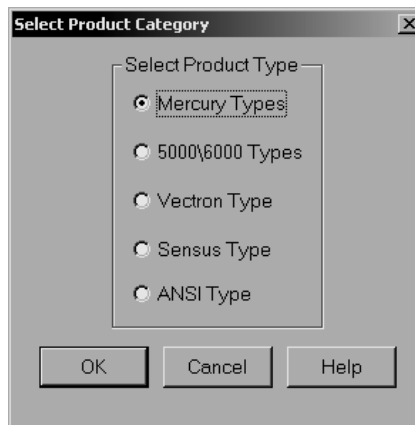

Device Type Selection Screen

The screenshot shows a dialog box titled "Add Remote Unit". It contains the following elements:

- Active
- New remote unit ID: 001234
- New account ID: 001234
- Copy from remote unit: 000444
- Product type: SIP
- Call profile: Every 12 hours
- Battery type: Lithium
- Instrument type: (empty dropdown)
- Instrument firmware version: (empty dropdown)
- IP Enabled
- Buttons: OK, Cancel, Help

Add Remote Unit Screen

Check the “Active” box to allow this device to be added to the list of all active devices.

For devices that will be communicating over the Internet check the “IP Enabled” box. For CSD devices leave this unchecked.

Enter the New Remote unit ID (RUID) that was assigned and programmed into the CNI2e using MP32.

Select “SIP” as the product type. Select the Call Profile that is desired.

Battery Type is simply for record keeping and does not alter the operation in any way.

Select OK when finished.

The “Copy From Remote Unit” feature allows you to define other CNI2e’s with similar characteristics to one that’s already defined. For instance suppose you define a new unit with an RUID of 001234. Now you need to define 49 other units but the only difference will be the RUID of each unit. Simply check the “Copy From Remote Unit” box and enter 001234 as the template. Then enter the new RUID in the New Remote unit ID box and select OK. All other parameters will be copied from the original template.

CONFIGURING THE CNI2E

The figure below illustrates one of the nine 'tabs' that can be accessed once a remote unit is defined. This screen will appear immediately after you've defined a new unit, or if you select a unit from the list that appears in the Remote Unit Configuration screen. Some of the fields like Battery Description are not critical and are primarily for record keeping. For instance, if a unit calls in to report a low-battery condition, it might be handy to know what type of battery to bring with you when you visit the site.

The screenshot shows a software window titled "Edit Remote Unit Data: 02ABBA Name: SIP-CB". It features a tabbed interface with the following tabs: Call Information, Relay Information, Hardware Alarms, Maintenance, General Information (selected), Input Description, Install Information, Party Line Definition, and Site Information. The "General Information" tab is active and contains the following fields and controls:

- Configuration:**
 - Product: SIP (text field)
 - Active: (checkbox)
 - Available HW inputs: 4 (text field)
 - Instrument firmware version: (dropdown menu)
 - Instrument type: (dropdown menu)
 - Control: (checkbox)
 - Audit Trail Date/Time Format: MM/DD/YY, DD/MM/YY, YY/MM/DD (radio buttons)
 - Access Code Information:
 - Access Code: (text field)
 - Edit Password: (text field)
- Battery Information:**
 - Date: 07/08/1996 (text field)
 - AC Powered: (checkbox)
 - Battery description: (list box containing "Lead Acid" and "Alkaline")
 - Buttons: Add, Remove
- Atmospheric pressure:** 14.4 (text field)
- Contract pressure:** 14.73 (text field)
- Standard command control:** Send Latest (dropdown menu)
- Special command control:** Send All (dropdown menu)
- Special command count:** 0 (text field)

At the bottom of the window are three buttons: OK, Cancel, and Help.

Remote Unit Configuration General Information Screen

With each call PowerSpring will ask the CNI2e for any data records that were accumulated since the last time it called in. This is referred to as a Send Latest operation and is the preferred method. A Send All operation instructs the CNI2e to send the entire contents of its memory from the oldest to the newest record. This method results in a long duration call and the most data sent, both of which can result in higher cellular service costs and reduced battery life.

CONFIGURING THE CNI2E'S PULSE-COUNTING INPUTS

Now select the Input Description tab. The following screen will appear.

Number of inputs: 4

Number	Description	Current Value Date/T	Current Value	Synchroni	Units in Effect	F
1	Pulse Input-1	10/27/2008 09:15:55	.0000	<input type="checkbox"/>	METER	1.00
2	Pulse Input-2	10/27/2008 09:15:55	.0000	<input type="checkbox"/>	METER	1.00
3	Pulse Input-3	10/27/2008 09:15:55	.0000	<input type="checkbox"/>	METER	1.00
4	Pulse Input-4	10/27/2008 09:15:55	.0000	<input checked="" type="checkbox"/>	METER	1.00

Buttons: Add..., Delete, Configure..., OK, Cancel, Help

Device Configuration Screen

It is important to select the correct number of data (pulse-counting) inputs and the time interval for counting pulse data, both of which were programmed into the CNI2e.

As mentioned earlier, a CNI2e can use its inputs for either pulse-counting or alarm sensing. If a combination is used then PowerSpring must be told how many channels are being used for pulse-counting.

In PowerSpring you must match the number of pulse-counting inputs to that of the CNI2e's. This is done by deleting inputs from the screen. However you can only delete inputs starting at the last input and working your way up.

Next you must define the pulse-counting interval, which applies to all channels that are configured for pulse-counting. Highlight one of the remaining channels on the screen and select the CONFIGURE button (or simply double-click on the selected channel). The following screen will appear.

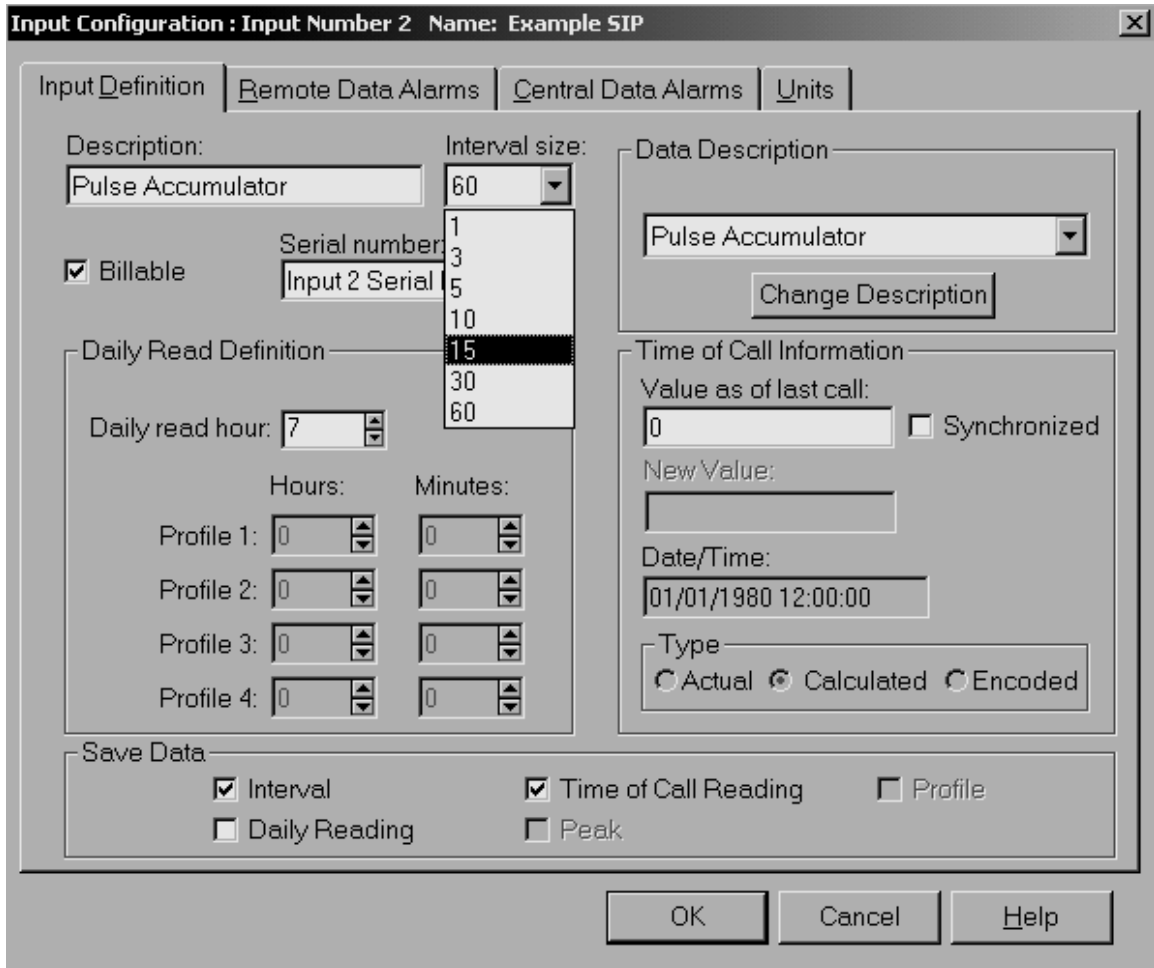

Data Input Configuration Screen

Select the Input Definition tab. Here you can match the time interval to that which was programmed into the CNI2e. This will apply to all pulse-counting channels. You can also change the description of each channel and select which type of data to save. Contact a Product Service Specialist if you need additional help with other selections on this screen.

CONFIGURING THE CNI2E'S CALL INFORMATION

Go back to the device configuration screen and select the Call Information tab. Proper configuration of the call information fields are essential to ensure that data will be collected and available for processing when expected. If the CNI2e is programmed to originate calls only then it will not be possible to initiate outbound calls since the cellular radio is not powered to receive incoming calls.

Edit Remote Unit Data: 02ABBA Name: SIP-CB

General Information | Input Description | Install Information | Party Line Definition | Site Information

Call Information | Relay Information | Hardware Alarms | Maintenance

Dial Out

Prefix: [] Phone number: [] Suffix: []

Long Distance

Target phone number:

[65.163.192.78]

IP Enabled

InvisiConnect Device

Go Transparent

Slave Device: []

View SIP-CB Cellular Parameters

Last Call

Date: [11/11/2008]

Time: [16:15:36]

Called In

Next Call

Date: [11/11/2008]

Time: [16:35:00]

Called In

Available Call Profiles:

Current Call Profile

Every 15 Min

Every 3 hours

Every 24 hours

Field Modem Type

Standard Metretek

Mercury A Mercury C

Mercury B Mercury D

OK Cancel Help

Call Information Screen

The Dial Out phone number is what PowerSpring will use to call the CNI2e. This might be used for a direct CSD call (“mobile-terminate”) or it may be used to “page” the unit, which will cause the unit to call back to the system. In either case this is usually the mobile phone number that was assigned to the cellular account. This field is automatically loaded whenever the CNI2e calls in to report a UNIT RESET alarm.

The Target Phone Number is for record keeping only and does not affect the operation of PowerSpring. This is the phone number or IP address that was programmed into the CNI2e and is what the CNI2e uses when placing a CSD call or making an Internet connection.

CONFIGURING THE CNI2E'S ALARMS

Go back to the device configuration screen and select the Hardware Alarms tab.

Hardware alarm count: 32

Show default descriptions for alarm list

Hardware alarm list:

Alarm	User Description
1	Magnetic Switch Alarm
2	Tamper Detect Alarm
3	Customer Alarm 1
4	Customer Alarm 2
5	AC On Alarm
6	AC Off Alarm
7	Unit Reset Alarm
8	Call Retry Alarm
9	KYZ 1 Input Failure
10	KYZ 2 Input Failure
11	KYZ 3 Input Failure
12	KYZ 4 Input Failure
13	Low Battery Alarm
14	Operating On Battery
15	...

Product type: SIP

Alarm Specification

Tamper Detect Alarm

Immediate Alarm Notification

Nuisance limit: 3

Save Log Alert

Available alarm user descriptions:

AC Off Alarm
AC On Alarm
AFM Acknowledge Off
AFM Acknowledge On
Backup Phone

Apply

OK Cancel Help

Hardware Alarm Configuration Screen

As discussed earlier, the CNI2e is capable of reporting a number of alarm conditions from external equipment and internal conditions. The CNI2e can be configured to call immediately when an alarm condition occurs or to simply report it on the next call. This screen allows you to configure how alarms are reported to PowerSpring by the CNI2e and by PowerSpring to you. It also allows you to change the verbal description of each alarm. For instance the generic “Customer Alarm-2” description might be changed to “Smoke Detector Alarm”.

Even if the CNI2e is configured to call immediately when an alarm occurs, in some cases PowerSpring can override this and simply have the alarm reported on the next scheduled call. For any alarm that requires an immediate call check the Immediate Alarm Notification box. Some alarms cannot be overridden because they are too important to ignore, such as a unit reset alarm. Make sure you have also programmed the CNI2e to place an immediate call for these alarms.

The Nuisance Limit can be used to disable calls due to a repeating alarm condition. As an example, say the CNI2e is scheduled to call in every 12 hours. One of the alarm inputs comes from a pressure sensor which has become defective. Until the sensor is repaired the CNI2e will keep calling in every couple of minutes to report a the pressure alarm. This is especially undesirable for battery-operated units because each call consumes power. But if you set the Nuisance Limit to 3 then PowerSpring will instruct the CNI2e to stop calling in after the third report of the same alarm. Later, when the CNI2e calls in at its regularly-scheduled time (12 hours later), the Nuisance Limit will be reset and the unit will again be allowed to report the alarm up to 3 times until the next scheduled call.

The SAVE checkbox allows the alarm condition to be recorded in the database. The LOG checkbox allows the alarm to be reported to the computer's printer or screen. The ALERT checkbox will activate the printer's audio alarm if a printer is used.

For each alarm be sure to select the APPLY button after you make any changes.

Note: Changes made to any alarm configuration will not go into effect until the next communication with the CNI2e.

Here is a general list of the alarms supported by the CNI2e. You can change the description of each alarm to more accurately describe its purpose. For instance "Customer Alarm 1" could be changed to "High Pressure".

Most electrical switches have only two contacts and are either normally-open (Form-A) or normally-closed (Form-B). A third configuration, Form-C, contains two switches, one of each type.

Customer Alarm-1

If Line #1 has been configured as a Form-A or Form-B alarm input the alarm will be reported as a "Customer Alarm-1" alarm.

If the combination of Line #1 & #2 has been configured as a Form-C alarm, then the alarm condition itself will be reported as a "Customer Alarm-1" alarm. If a switch failure is detected, the failure is reported as a "Customer Alarm-2" alarm.

Customer Alarm-2

If Line #2 has been configured as a Form-A or Form-B alarm input the alarm will be reported as a "Customer Alarm-2" alarm.

If the combination of Line #1 & #2 has been configured as a Form-C alarm then see the discussion for the Customer Alarm-1 alarm.

Magnetic or "CALL" Switch Alarm

If Line #9 has been configured as a Form-A or Form-B alarm input the alarm will be reported as a MAGNETIC SWITCH or CALL SWITCH alarm.

If the combination of Line #9 & #10 has been configured as a Form-C alarm, then the alarm condition itself will be reported as a MAGNETIC SWITCH or CALL SWITCH alarm. If a switch failure is detected, the failure is reported as a TAMPER alarm.

TAMPER Detect Alarm

If Line #10 has been configured as a Form-A or Form-B alarm input the alarm will be reported as a TAMPER alarm.

If the combination of Line #9 & #10 has been configured as a Form-C alarm then see the discussion for the Magnetic or "CALL" Switch alarm.

AC-OFF Alarm

If Line #11 has been configured as a Form-A or Form-B alarm input an active alarm will be reported as an AC-OFF alarm.

AC-ON Alarm

If Line #11 has been configured as a Form-A or Form-B alarm input an inactive alarm will be reported as an AC-ON alarm.

KYZ4 Alarm

If Line #12 has been configured as a Form-A or Form-B alarm input an active alarm will be reported as an "KYZ4" alarm.

Unit Reset Alarm

Reports if the CNI2e has been reset. A reset can be caused by the following conditions:

- 1 - The JP4 reset pins are shorted together.
- 2 - The board's configuration memory or operating code has been changed or read using the programming cable.
- 3 - The battery is nearly exhausted and can no longer support the current required by the board.

Call Retry Alarm

If a previous call attempt failed then this alarm will be reported on the next successful call. Numerous Call Retry alarms may be an indication of network problems or that the unit is located in a marginal reception area. It may also happen if too many units are programmed to call the data collection system at the same time.

Queue Full Alarm

If pulse data is not collected often enough there is a chance that the oldest data may be lost due to insufficient memory. This memory is referred to as the "queue" and the CNI2e will call in to report a "Queue Full" alarm when a certain percentage of the queue contains new records. Default value is 75% but can be changed using MP32.

Clock Resync Alarm

The CNI2e's time-of-day clock is updated each time it calls in to the data collection system. A Clock Resync alarm is reported if the CNI2e's clock has been corrected by more than ± 20 seconds, and will be reported on the next call. Be aware that there will always be a Clock Resync alarm reported on the next call after a unit reset call, and this is normal.

Frequent Clock Resync alarms may indicate one of the following problems:

- 1 - The CNI2e cannot properly keep time due to a timekeeping hardware fault.

2 - The time given to the CNI2e is taken from the computer's time-of-day clock. This alarm may indicate that the computer's clock is inaccurate (slow, fast or has been changed since the last call, such as a daylight savings time (DST) change).

3 - If the CNI2e is programmed to call more than one computer, and the computers' clocks are different by more than 20 seconds, this will result in Clock Resync alarms.

4 - During packet (Internet) connections PowerSpring prepares the message containing the new time-of-day and sends it to the CNI2e. If a packet does not arrive after a certain amount of time, the same packet is retransmitted. This will be repeated several more times before the connection is terminated. If it takes over 20 seconds to deliver the packet, then the time in the message will be 20 seconds older than the CNI2e's current time.

Remote Daily Volume Low Input-1,2,3,4

These alarms occur if the daily volume use is below the limits for pulse inputs 1, 2, 3 and 4, respectively.

Remote Daily Volume High Input-1,2,3,4

These alarms occur if the daily volume use is above the limits for pulse inputs 1, 2, 3 and 4, respectively.

Remote TTI Consumption Low Input-1,2,3,4

These alarms occur if the interval volume use is below the limits for pulse inputs 1, 2, 3 and 4, respectively.

Remote TTI Consumption High Input-1,2,3,4

These alarms occur if the interval volume use is above the limits for pulse inputs 1, 2, 3 and 4, respectively.

Low Battery Alarm

This alarm indicates that the battery pack in the CNI2e needs to be replaced as soon as possible. The voltage level at which the alarm will occur is programmed using MP32. The battery should be changed as soon as possible to continue uninterrupted service.

Note About Batteries

Battery voltage level drops in cold weather. If the unit is located in cold climates you may receive occasional low-battery alarms as the temperature drops. As the unit warms up during the day the voltage may return to acceptable levels. However, any low-battery alarm should be taken seriously and the battery should be replaced soon. If the battery gets too low the unit may no longer be able to make calls and may not be able to save its' pulse data.

DEFINING THE CNI2E – AUTOMATIC MODE

Manually defining a large deployment of CNI2e's in larger systems can be tedious. In many cases the only difference between all of these units will be their remote unit ID (RUID) numbers. As long as all other parameters are the same there is a way to automate this process.

First, go to the Remote Unit Selection Screen and locate a template called "\$CNI2e". Select this for editing to define all of the parameters that you will need for your CNI2e's.

If you look at the General Information tab on the Remote Unit Configuration screen you will see a checkbox called "Active". As long as this box is checked any new CNI2e that calls in for the very first time will be automatically added to the system under the RUID number that was programmed into the unit. If the "Active" box is not checked then the call will be rejected unless you manually add the unit to the system.

STARTING POWERSPRING

Once all CNI2e's have been defined you can start PowerSpring. For CSD connections the appropriate modem channels will be initialized. For packet (Internet) connections the SIP server will be started and will begin listening on the number of channels that were selected.

PowerSpring is a powerful and highly-configurable application program. There are many features not discussed here. A Honeywell Product Support Specialist can provide more information and training options.

OBTAINING THE CNI2E'S CELLULAR PHONE NUMBER

Whenever a CNI2e calls in to report a UNIT RESET alarm PowerSpring will ask for its Mobile Directory Number (MDN), which is usually the phone number that was assigned to the cellular account. PowerSpring saves this number in the database and also places it in the Call Information tab on the Remote Unit Configuration screen. It appears as the Dial-Out number.

For this feature to work on the CNI2e-H the mobile phone number must be stored on the SIM card. There are usually three or four memory slots reserved for this, one for voice (which is usually considered the primary mobile number), another for a data number (usually used for "mobile-terminate" CSD service) and a third for a FAX number. The CNI2e-H will report the 1st mobile number stored on the SIM card. If you are using the phone number for paging purposes then this should be the voice number. If you wish to make mobile-terminate CSD calls then this should be the data number. Confirm with your cellular service provider to make sure the right number is stored on the SIM card.

OBTAINING THE CNI2E'S HARDWARE STATUS AND CELLULAR INFORMATION

Each time the CNI2e communicates with PowerSpring it starts the communications process by sending a short message containing information about alarms, status, its time-of-day and other pertinent information.

In packet (Internet) mode, the CNI2e also sends additional information about cellular status, battery voltage, error codes, etc. In PowerSpring you can view this information from the Call Information screen. Select the View CNI2e Cellular Parameters button on the right-hand side of the screen.

The screenshot shows a software window titled "Edit Remote Unit Data: 02ABBA Name: SIP-CB". It features a tabbed interface with the following tabs: "General Information", "Input Description", "Install Information", "Party Line Definition", and "Site Information". The "Call Information" tab is selected, and it contains several sub-sections: "Dial Out" with fields for Prefix, Phone number, and Suffix, and a checkbox for "Long Distance"; "Target phone number:" with a text box containing "65.163.192.78"; "Last Call" with fields for Date (11/11/2008) and Time (16:15:36), and a checkbox for "Called In"; "Next Call" with fields for Date (11/11/2008) and Time (16:35:00); "Available Call Profiles:" with a list box containing "Every 15 Min", "Every 3 hours", and "Every 24 hours"; and "Field Modem Type" with radio buttons for Standard, Metretek, Mercury A, Mercury B, Mercury C, and Mercury D. A "View SIP-CB Cellular Parameters" button is located in the middle-right area. At the bottom of the window are "OK", "Cancel", and "Help" buttons.

Viewing the Cellular and Hardware Status

The following information screen will appear.

The screenshot shows a window titled "Cellular Call Parameters" with a close button in the top right corner. The window contains several input fields and a list box. The fields are arranged in two columns. The left column contains: Internal Logic Volts (3.3), Lithium Battery Volts (3.6), Super Cap Volts (3.5), Site Temp Deg C (24.9), and Registration Status (001). The right column contains: Tower ID (338b), Tower Location (6a80), Cellular Provider Name (Cingular), Signal Strength (Bars 1-5) (3), and Cellular Account Phone Number (13218488101). Below these fields is an "Error Codes Stack" list box containing the text "NULL". A "Close" button is located at the bottom right of the window.

Internal Logic Volts	Tower ID	Tower Location
3.3	338b	6a80
Lithium Battery Volts	Cellular Provider Name	
3.6	Cingular	
Super Cap Volts	Signal Strength (Bars 1-5)	
3.5	3	
Site Temp Deg C	Cellular Account Phone Number	
24.9	13218488101	
Registration Status	Number of Good Calls	Number of Bad Calls
001	0	0

Error Codes Stack

NULL

Close

Cellular and Hardware Status Screen

The Error Code Stack is a list of the most recent 30 errors that were detected and displayed on the LEDs. The most recent code appears first. Besides pointing out hardware problems certain other codes might explain why calls are failing and have to be retried. For instance you might see codes relating to loss of signal or network registration, both of which might indicate that the unit is in a marginal reception area.

The Registration Status number will be '001' for registration on the "home" network or '005' for registration on a roaming network.

Earlier versions of the data collection software (DC-2000) do not process the CNI2e's additional information but it can be viewed using a utility called Call Diagnostic Dump.



Starting the Call Diagnostic Dump Utility

When PowerSpring processes the CNI2e's information it creates a file called a "raw file". This is usually stored in the Data Processing folder and is usually in a sub folder called "Output". Each file has an extension of ".raw". The filename itself is a conglomeration of the date, time and a sequence number. It does not contain the unit's ID number, so finding the right file is somewhat difficult. But the Diagnostic Dump utility does have a way to select only raw files that are associated with a particular RUID.

In the next figure we show how a raw file is displayed. You will see that the unit's RUID number appears at the top of the screen along with the time of the call.

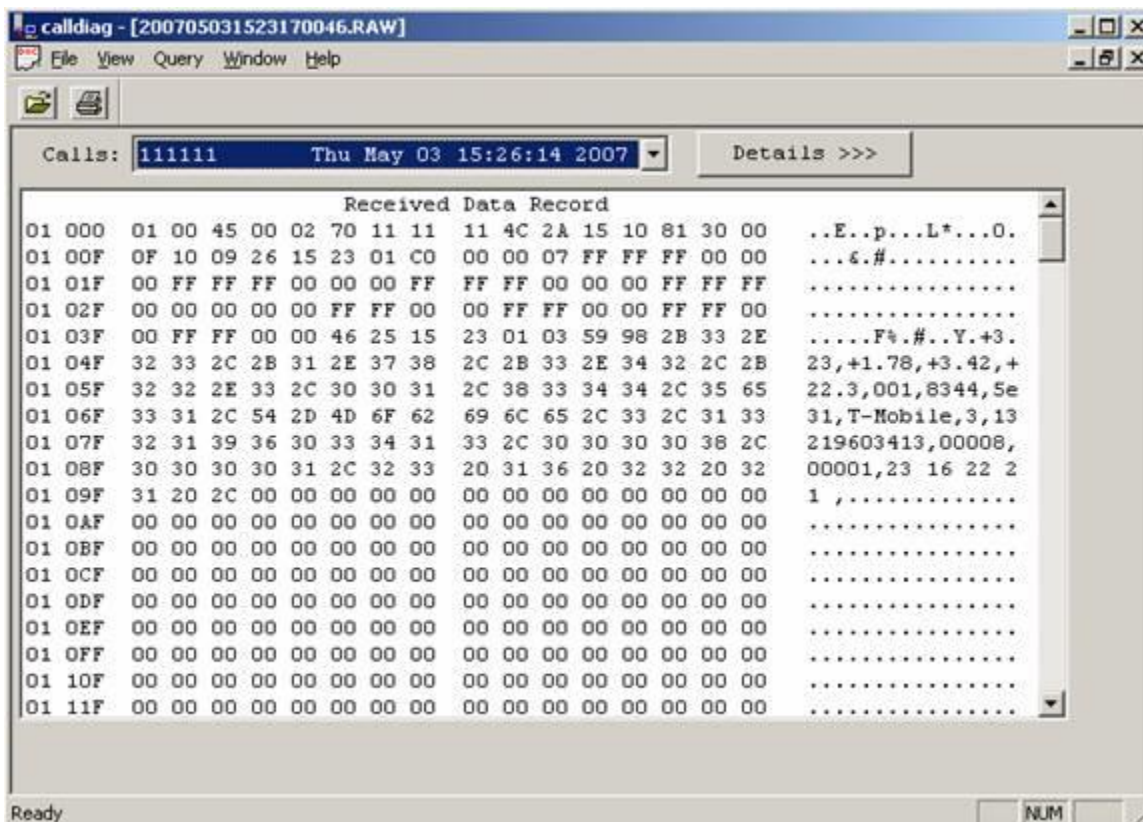

Using the Call Diagnostic Dump Utility

The screen is formatted to show the data in both hexadecimal and ASCII format. Most of the information on the ASCII side of the screen is readable and contains information about the CNI2e's power condition and cellular status. This portion of the message is highlighted in the next figure.

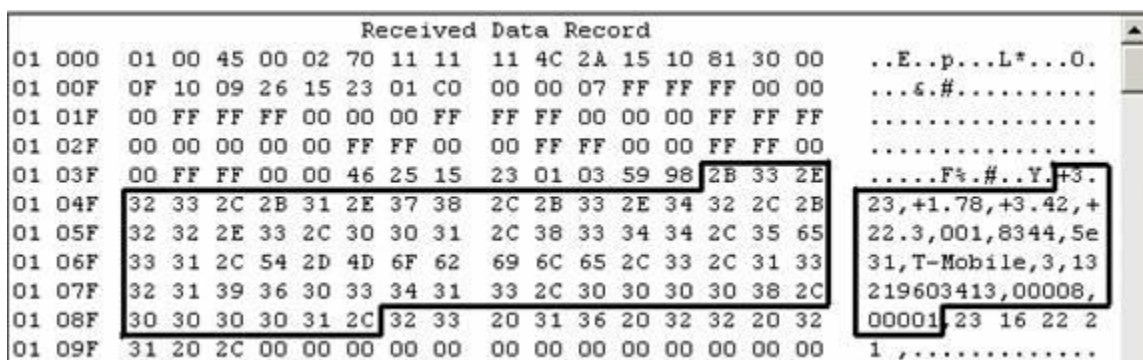

Status and Cellular Information on the Call Dump Screen

Here is how the information is formatted in the order it appears, including any commas (,) that separate each item. All characters except "NULL" characters are ASCII formatted:

Parameter Item	Example
Internal logic supply voltage (volts)	+3.23,
Power voltage (volts)	+07.2,
Radio power voltage (volts)	+3.62,
Temperature at site (°C) ($\pm 2^{\circ}\text{C}$)	+22.3,
Cellular registration status: 001 = registered on home network, 005 = registered on roaming network	001,
Cellular tower location (4-digit hex)	8344,
Cellular tower ID number (4-digit hex)	5e31,
Cellular provider's name	T-Mobile,
Signal strength at time of call (in terms of "bars" (1 – 5)	3,
Cellular mobile directory number (phone number assigned to account) (Note-1)	13213946414,
Number of successful calls since reset	00008,
Number of unsuccessful calls since reset	00001,
Up to last 30 error codes (Note-2)	23 45 43 4332,
Maximum packet size (bytes)	001000
NULL character	0
Radio's MEID or IMEI serial number	A000001234567
NULL character	0

Cellular Information Fields

Note-1: The phone number may include characters such as international dialing prefixes.
Status and Cellular Information

Note-2: Each 2-digit error code is separated by a space and the list ends with a comma (,). The most recent code appears first. There can be up to 30 codes listed. Besides pointing out hardware problems, certain other codes might explain why calls are failing and have to be retried. For instance, you might see codes relating to loss of signal or network registration, both of which might indicate that the unit is in a marginal reception area.

This portion of the raw file could be processed as a comma-delimited file by a spreadsheet program. But beware that the length of the data preceding this information is variable, so this information block may not always start at the same location with each call.

TROUBLESHOOTING GUIDE

HARDWARE ALARM-SENSING

SYMPTOM	POSSIBLE CAUSE
<p>The CNI2e does not respond to or report a hardware alarm condition.</p>	<ul style="list-style-type: none"> • The input may not be configured as an ALARM input. • The input may not be configured for the correct switch type (Form-A, Form-B, Form-C). • The alarm event may not last long enough (debounce and/or sample rates may not be correct). • The “Immediate Call on Input Going Active” option is turned off or the host system may be overriding this setting. • The “Originate Calls” option is turned off. • The input is not of the dry-contact type.
<p>The CNI2e does not call in when a hardware alarm occurs but does report the event on the next communications session.</p>	<ul style="list-style-type: none"> • The “Immediate Call on Input Going Active” option is turned off or the host system may be overriding this setting. • The “Originate Calls” option is turned off.
<p>The CNI2e calls in when a hardware alarm occurs but does not describe the alarm.</p>	<ul style="list-style-type: none"> • The host system may not have the ability to report this particular alarm.
<p>The CNI2e keeps reporting the same hardware alarm condition.</p>	<ul style="list-style-type: none"> • The host system is not instructing the CNI2e to clear the alarm condition. • The alarm input is erratic. • The debounce and/or sample rates may not be correct for this type of input. • The input may actually be a data (pulse-counting) line that is improperly configured as an ALARM input.

Hardware Alarm-Sensing Troubleshooting Guide

PULSE-COUNTING

SYMPTOM	POSSIBLE CAUSE
The CNI2e does not report any counts for an input.	<ul style="list-style-type: none">• The input may not be configured as a PULSE COUNTING input.• The input may not be configured for the correct switch type (Form-A, Form-B, Form-C).• The pulse event may not last long enough (debounce and/or sample rates may not be correct).• Too many channels are defined as pulse-counting inputs (maximum of 4 when configured as a Metretek SIP, maximum of 2 when configured as a Mercury PA or Mini-Max).• The input is not of the dry-contact type.
The counts reported are too low or too high.	<ul style="list-style-type: none">• The debounce and/or sample rates may not be correct for this type of input.• The input is erratic.• The time-tagged interval size is not properly configured.

Pulse-Counting Troubleshooting Guide

POWER SOURCE

SYMPTOM	POSSIBLE CAUSE
The CNI2e reports a low-battery condition too soon or too late.	<ul style="list-style-type: none"> • The Low Battery alarm set-point is not correct for the type of battery installed.
The CNI2e never calls in to report a low-battery condition.	<ul style="list-style-type: none"> • The “Immediate Call on Low Battery Condition” option is turned off or the host system may be overriding this setting. • The Low Battery alarm set-point is not correct for the type of battery installed.
The CNI2e calls in multiple times in a row to report a low-battery condition.	<ul style="list-style-type: none"> • The host system’s (PowerSpring’s) “nuisance limit” is set too high. • The host system is not instructing the CNI2e to clear the alarm condition.
The batteries need to be replaced too often.	<ul style="list-style-type: none"> • Call-in schedule is too aggressive. • Calls last too long for a battery-operated device. • Retry strategy is too aggressive. • The CNI2e is configured to respond to voice or SMS pages. • The CNI2e is configured to enter Server Mode too often or for periods that are too long for a battery-operated device. • Session Timeout value is set too high. Recommended value is 30 seconds. • On the CNI2e-C the configuration jumpers JP3-4 and/or JP3-5 are installed in the “B-C” position. This does not allow the CNI2e to turn off the power source to the radio.
Some calls terminate early and end with an LED Error Code of “3-0”, “3-1” or “3-2”.	<ul style="list-style-type: none"> • The call or retry schedule may be too aggressive, not allowing the batteries or the super-capacitor enough time to recover from the previous call.

Power Source Troubleshooting Guide

NETWORK LOW-SIGNAL PROBLEMS

SYMPTOM	POSSIBLE CAUSE
The CNI2e displays an LED Error code of "1-2" or "1-3".	<ul style="list-style-type: none">• Poor signal or interference in the area where the CNI2e is located.• Cellular account has not been established or is improperly setup by the service provider.• Incorrect provisioning information on the SIM card (CNI2e-H) or in the radio (CNI2e-C).
The CNI2e reports low signal strength on each call (1 or 2 bars).	<ul style="list-style-type: none">• Poor signal or interference in the area where the CNI2e is located.

Network Low-Signal Troubleshooting Guide

NETWORK CONNECTION PROBLEMS (CLIENT MODE)

SYMPTOM	POSSIBLE CAUSE
<p>The CNI2e starts the connection (call-in) process but terminates after several seconds. Often followed by an LED Error Code "4-2".</p>	<ul style="list-style-type: none"> • PAP username or password is incorrect or not required. • Cellular account has not been setup for the type of service being requested (such as Internet access). • For the CNI2e-H units the Access Point Name (APN) may be incorrect. • Incorrect provisioning information on the SIM card (CNI2e-H) or in the radio (CNI2e-C). • The cellular service provider may only support Mobile Internet Protocol ("MIP") and not Simple Internet Protocol ("SIP"). • Marginal signal strength or interference where the CNI2e is located.
<p>The CNI2e starts the connection (call-in) process but terminates after 20-30 seconds. Often followed by an LED Error Code "4-3".</p>	<ul style="list-style-type: none"> • Destination IP address or port number for the host system is incorrect. • Host system is not running. • Host system's firewall protection equipment is blocking the call. • For the CNI2e-H the Access Point Name (APN) may be incorrect. • Marginal signal strength or interference where the CNI2e is located.
<p>A connection is established with the host system but terminates early. This happens occasionally. Often followed by an LED Error Code "4-4", "4-5" or "4-7".</p>	<ul style="list-style-type: none"> • Marginal signal strength or interference where the CNI2e is located. • Network terminated the connection during the call.
<p>A connection is established with the host system but terminates early. This happens every time. Often followed by an LED Error Code "4-6".</p>	<ul style="list-style-type: none"> • The host system may not be properly configured for this device (undefined ID number, incorrect interval size, wrong number of pulse-counting inputs, etc.)

Network Connection (Client Mode) Troubleshooting Guide

NETWORK CONNECTION PROBLEMS (SERVER MODE)

SYMPTOM	POSSIBLE CAUSE
<p>The CNI2e will not enter Server Mode.</p>	<ul style="list-style-type: none"> • The “Allow Connection Requests” option is turned off. • The cellular account has not been setup for this type of service.
<p>The CNI2e is configured to establish a Server Session when a hardware input goes active. But this does not happen.</p>	<ul style="list-style-type: none"> • The input may not be configured as a “SPECIAL PURPOSE” input. • The “Allow Connection Requests” option is turned off. • The input may not be configured for the correct switch type (Form-A, Form-B, Form-C). • The input event may not last long enough (debounce and/or sample rates may not be correct). • The input is not of the dry-contact type.
<p>The CNI2e starts a Server session but terminates after several seconds. Sometimes followed by an LED Error Code “4-2”.</p>	<ul style="list-style-type: none"> • PAP Username or password is incorrect or not required. • Cellular account has not been setup for this type of service. • For the CNI2e-H the Access Point Name (APN) may be incorrect. • Incorrect provisioning information on the SIM card (CNI2e-H) or in the radio (CNI2e-C). • The cellular service provider may only support Mobile Internet Protocol (“MIP”) and not Simple Internet Protocol (“SIP”). • Marginal signal strength or interference where the CNI2e is located. • This could happen if the CNI2e is configured to start the Server Session with a hardware input event, and end the session after the “Server Duration” time expires, and the “Server Duration” is too short or zero.

Network Connection (Server Mode) Troubleshooting Guide

<p>The CNI2e is configured to establish a Scheduled Server Session but this does not happen.</p>	<ul style="list-style-type: none"> • The “Allow Connection Requests” option is turned off. • The cellular account has not been setup for this type of service. • There are no days-of-the-week and/or hours-of-the-day selected. • The CNI2e was unable to obtain the current time from any host system or from one of five NIST time servers. • The time zone adjustment and/or Daylight Savings Times settings are incorrect, causing the CNI2e to enter Server Mode at an unexpected time.
<p>The CNI2e enters Server Mode but cannot be contacted.</p>	<ul style="list-style-type: none"> • The client (host) system has the wrong IP address and/or port number for the CNI2e. • The cellular account has not been set up with a static IP address. • The cellular account has not been setup for this type of service. • The “Friends List” is turned on but the list does not include the IP address of the client (host) system.

Network Connection (Server Mode) Troubleshooting Guide (continued)

SERIAL PORT

SYMPTOM	POSSIBLE CAUSE
<p>The CNI2e cannot establish communications with the device attached to its serial port.</p>	<ul style="list-style-type: none"> • Incorrect baud rate, parity, stop bits or character length. • Incorrect serial port selected. • “Allow Transparent” option is turned off. • Configuration jumper JP3-3 is not in the correct location for this type of serial connection. • Some serial devices need a special response or keyword to allow the communications to begin. For instance a “CONNECT” message. The CNI2e may not be properly configured to send this type of message to the device. • The handshaking selection may not be proper for the device.
<p>The CNI2e will not accept a dial-out (“ATD”) command from the device attached to its serial port.</p>	<ul style="list-style-type: none"> • In most applications the CNI2e will enter a low-power sleep mode between calls. If the CNI2e is brought out of this mode by the reception of data from the serial device, it may miss the first character of the ATD command and therefore not recognize it as an ATD command. The serial device should be configured to repeat the command within 15 seconds, or precede the command with one or two “AT” commands. • Configuration jumper JP3-2 is not installed in the correct location for the CNI2e to recognize incoming data from the serial device. • Configuration jumper JP3-3 is not in the correct location for this type of serial connection.
<p>The CNI2e accepts a dial-out (“ATD”) command from the device attached to its serial port but cannot connect to the host system. Often followed by an LED Error Code “4-3”.</p>	<ul style="list-style-type: none"> • The destination phone number or IP address/port number included in the ATD command may be wrong or improperly formatted. • Host system is not running. • Host system’s firewall protection equipment is blocking the call.

Serial Port Troubleshooting Guide

<p>The CNI2e establishes a connection between the device attached to its serial port and the host system. But the connection terminates early.</p>	<ul style="list-style-type: none">• The CNI2e received a command from the serial device to terminate the connection (such as “+++” or “ATH”).• The CNI2e is configured to terminate the call when the DTR line goes inactive, and that happened during the call.• The network or host system terminated the connection.• Marginal signal strength or interference where the CNI2e is located.• The “Session Timeout” period may be too short, not allowing the host or the serial device enough time to respond.• In IP mode, the “Delay Before Sending Packets” time value may be too short. This can cause messages from the serial device to be split into several smaller messages, which the host system may not be able to handle.
--	---

Serial Port Troubleshooting Guide (continued)

CSA CONTROL / INSTALLATION DRAWINGS

This label appears on an outer surface of the CNI2e assembly.

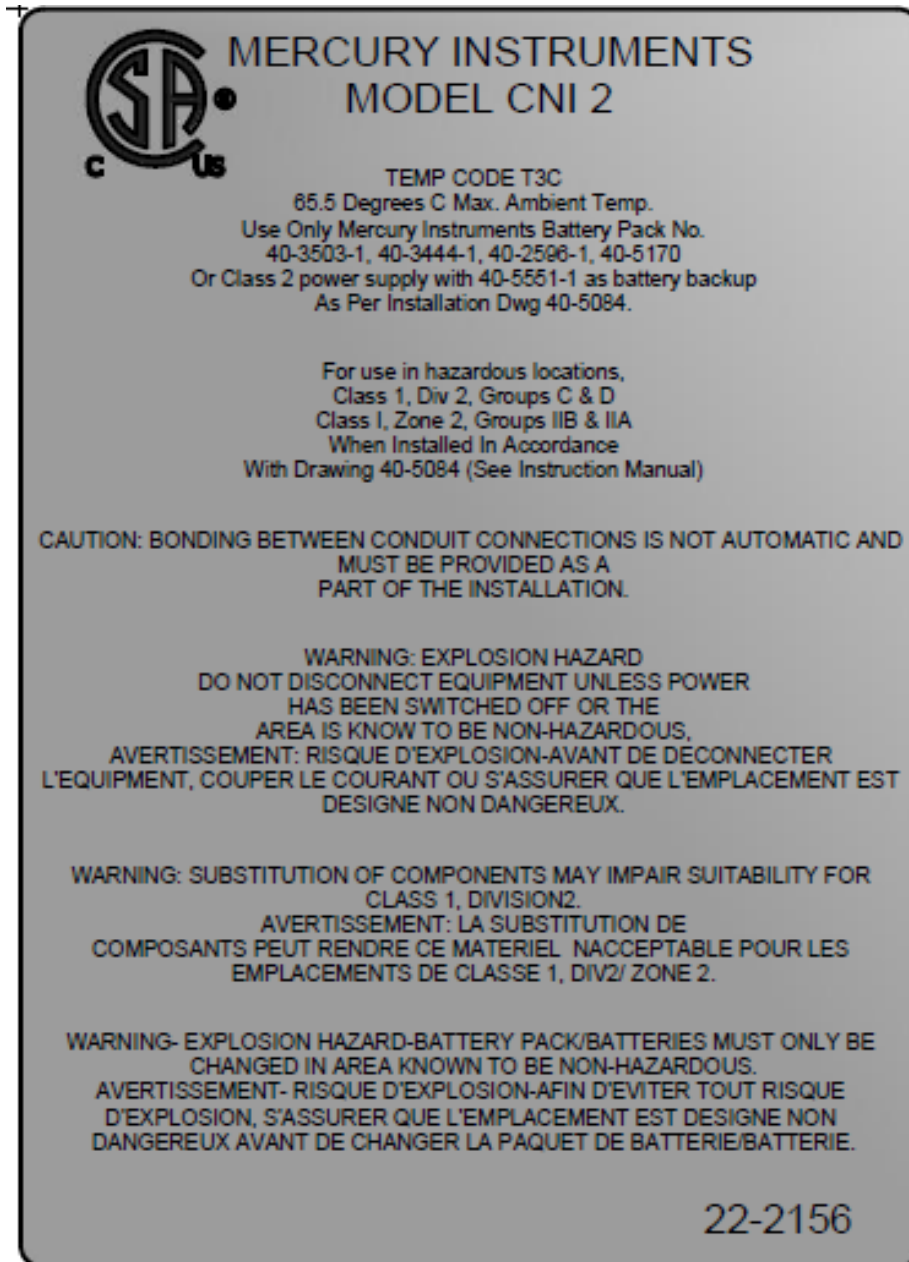

CSA Safety Label

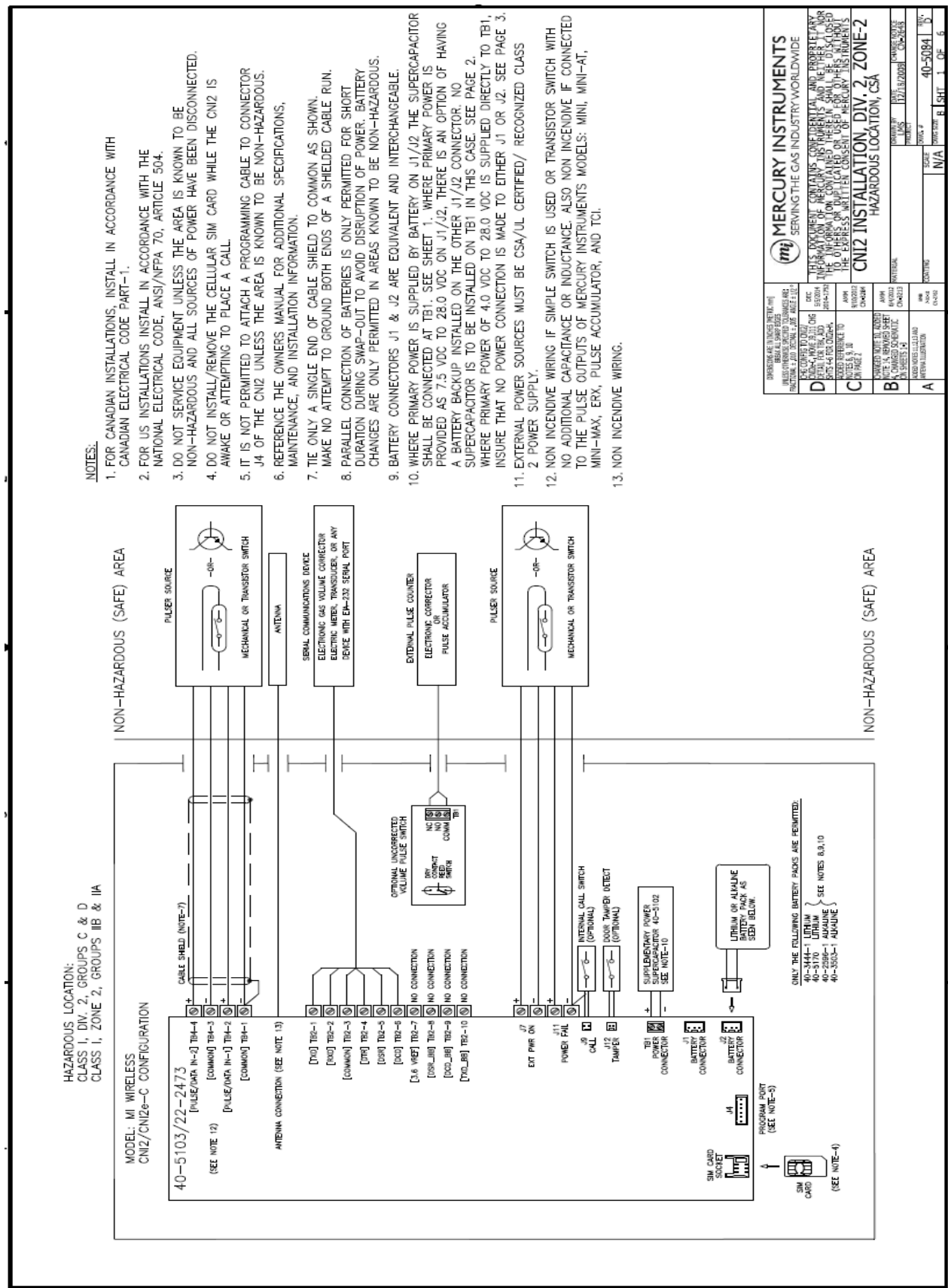

NOTES:

- FOR CANADIAN INSTALLATIONS, INSTALL IN ACCORDANCE WITH CANADIAN ELECTRICAL CODE PART-1.
- FOR US INSTALLATIONS INSTALL IN ACCORDANCE WITH THE NATIONAL ELECTRICAL CODE, ANSI/NFPA 70, ARTICLE 504.
- DO NOT SERVICE EQUIPMENT UNLESS THE AREA IS KNOWN TO BE NON-HAZARDOUS AND ALL SOURCES OF POWER HAVE BEEN DISCONNECTED.
- DO NOT INSTALL/REMOVE THE CELLULAR SIM CARD WHILE THE CNI2 IS AWAKE OR ATTEMPTING TO PLACE A CALL.
- IT IS NOT PERMITTED TO ATTACH A PROGRAMMING CABLE TO CONNECTOR J4 OF THE CNI2 UNLESS THE AREA IS KNOWN TO BE NON-HAZARDOUS.
- REFERENCE THE OWNERS MANUAL FOR ADDITIONAL SPECIFICATIONS, MAINTENANCE, AND INSTALLATION INFORMATION.
- TIE ONLY A SINGLE END OF CABLE SHIELD TO COMMON AS SHOWN. MAKE NO ATTEMPT TO GROUND BOTH ENDS OF A SHIELDED CABLE RUN.
- PARALLEL CONNECTION OF BATTERIES IS ONLY PERMITTED FOR SHORT DURATION DURING SWAP-OUT TO AVOID DISRUPTION OF POWER. BATTERY CHANGES ARE ONLY PERMITTED IN AREAS KNOWN TO BE NON-HAZARDOUS.
- BATTERY CONNECTORS J1 & J2 ARE EQUIVALENT AND INTERCHANGEABLE.
- WHERE PRIMARY POWER IS SUPPLIED BY BATTERY ON J1/J2, THE SUPERCAPACITOR SHALL BE CONNECTED AT TB1. SEE SHEET 1. WHERE PRIMARY POWER IS PROVIDED AS 7.5 VDC TO 28.0 VDC ON J1/J2, THERE IS AN OPTION OF HAVING A BATTERY BACKUP INSTALLED ON THE OTHER J1/J2 CONNECTOR. NO SUPERCAPACITOR IS TO BE INSTALLED ON TB1 IN THIS CASE. SEE PAGE 2. WHERE PRIMARY POWER OF 4.0 VDC TO 28.0 VDC IS SUPPLIED DIRECTLY TO TB1, INSURE THAT NO POWER CONNECTION IS MADE TO EITHER J1 OR J2. SEE PAGE 3.
- EXTERNAL POWER SOURCES MUST BE CSA/UL CERTIFIED/ RECOGNIZED CLASS 2 POWER SUPPLY.
- NON INCENDIVE WIRING IF SIMPLE SWITCH IS USED OR TRANSISTOR SWITCH WITH NO ADDITIONAL CAPACITANCE OR INDUCTANCE. ALSO NON INCENDIVE IF CONNECTED TO THE PULSE OUTPUTS OF MERCURY INSTRUMENTS MODELS: MINI, MINI-AT, MINI-MAX, ERX, PULSE ACCUMULATOR, AND TCI.
- NON INCENDIVE WIRING.

MERCURY INSTRUMENTS SERVING THE GAS INDUSTRY WORLDWIDE	
THIS DOCUMENT CONTAINS CONFIDENTIAL AND PROPRIETARY INFORMATION OF MERCURY INSTRUMENTS AND THE INFORMATION CONTAINED HEREIN SHALL BE DISCLOSED TO OTHERS WITHOUT THE WRITTEN CONSENT OF MERCURY INSTRUMENTS.	DATE: 12/18/2008 REV: 01 CNI2-2
DRAWN BY: N/A CHECKED BY: N/A SCALE: N/A SHEET # OF: 1 OF 6	DATE: 12/18/2008 REV: 01 CNI2-2

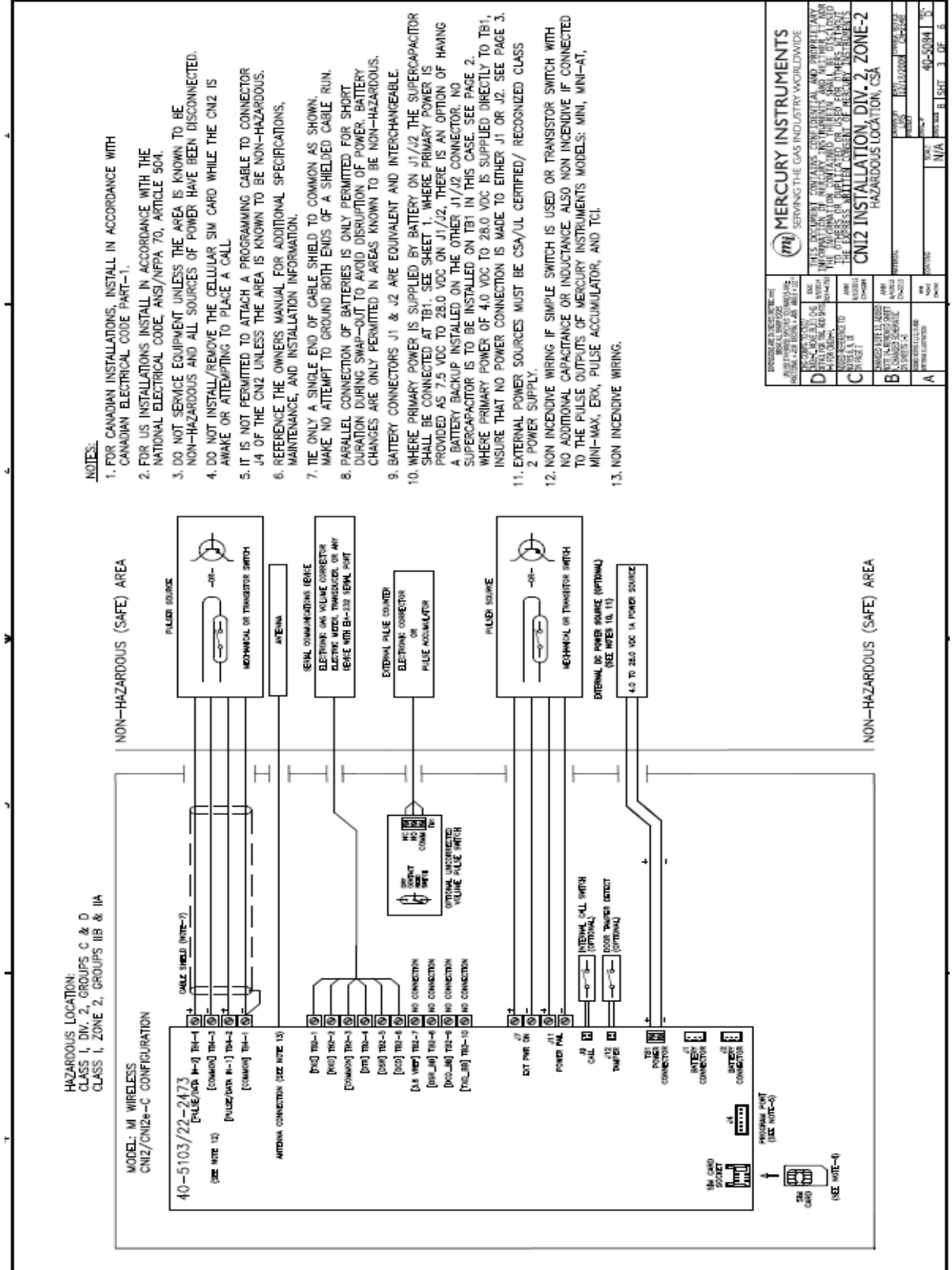

NOTES:

- FOR CANADIAN INSTALLATIONS, INSTALL IN ACCORDANCE WITH CANADIAN ELECTRICAL CODE PART-1.
- FOR US INSTALLATIONS INSTALL IN ACCORDANCE WITH THE NATIONAL ELECTRICAL CODE, ANSI/NFPA 70, ARTICLE 504.
- DO NOT SERVICE EQUIPMENT UNLESS THE AREA IS KNOWN TO BE NON-HAZARDOUS AND ALL SOURCES OF POWER HAVE BEEN DISCONNECTED.
- DO NOT INSTALL/REMOVE THE CELLULAR SIM CARD WHILE THE CN1Z IS AWAKE OR ATTEMPTING TO PLACE A CALL.
- IT IS NOT PERMITTED TO ATTACH A PROGRAMMING CABLE TO CONNECTOR J4 OF THE CN1Z UNLESS THE AREA IS KNOWN TO BE NON-HAZARDOUS.
- REFERENCE THE OWNERS MANUAL FOR ADDITIONAL SPECIFICATIONS, MAINTENANCE, AND INSTALLATION INFORMATION.
- TIE ONLY A SINGLE END OF CABLE SHIELD TO COMMON AS SHOWN. MAKE NO ATTEMPT TO GROUND BOTH ENDS OF A SHIELDED CABLE RUN.
- PARALLEL CONNECTION OF BATTERIES IS ONLY PERMITTED FOR SHORT DURATION DURING SWAP-OUT TO AVOID DISRUPTION OF POWER. BATTERY CHANGES ARE ONLY PERMITTED IN AREAS KNOWN TO BE NON-HAZARDOUS.
- BATTERY CONNECTORS J1 & J2 ARE EQUIVALENT AND INTERCHANGEABLE.
- WHERE PRIMARY POWER IS SUPPLIED BY BATTERY ON J1/J2 THE SUPERCAPACITOR SHALL BE CONNECTED AT TB1. SEE SHEET 1, WHERE PRIMARY POWER IS PROVIDED AS 7.5 VDC TO 28.0 VDC ON J1/J2, THERE IS AN OPTION OF HAVING A BATTERY BACKUP INSTALLED ON THE OTHER J1/J2 CONNECTOR. NO SUPERCAPACITOR IS TO BE INSTALLED ON TB1 IN THIS CASE. SEE PAGE 2, WHERE PRIMARY POWER OF 4.0 VDC TO 28.0 VDC IS SUPPLIED DIRECTLY TO TB1, INSURE THAT NO POWER CONNECTION IS MADE TO EITHER J1 OR J2. SEE PAGE 3.
- EXTERNAL POWER SOURCES MUST BE CSA/UL CERTIFIED/ RECOGNIZED CLASS 2 POWER SUPPLY.
- NON INCENDIVE WIRING IF SIMPLE SWITCH IS USED OR TRANSISTOR SWITCH WITH NO ADDITIONAL CAPACITANCE OR INDUCTANCE. ALSO NON INCENDIVE IF CONNECTED TO THE PULSE OUTPUTS OF MERCURY INSTRUMENTS MODELS: MINI, MINI-AT, MINI-MAX, EXX, PULSE ACCUMULATOR, AND TCI.
- NON INCENDIVE WIRING.

MERCURY INSTRUMENTS SERVING THE GAS INDUSTRY WORLDWIDE	
D THIS DOCUMENT CONTAINS CONFIDENTIAL AND PROPRIETARY INFORMATION. THE INFORMATION CONTAINED HEREIN IS TO BE KEPT UNCLASSIFIED AND UNCONTROLLED UNLESS OTHERWISE INDICATED BY THE ADDRESS, CARRIER OR LABEL OR USED FOR OTHER PURPOSES WITHOUT THE EXPRESS WRITTEN CONSENT OF MERCURY INSTRUMENTS.	CN1Z INSTALLATION, DIV. 2, ZONE-2 HAZARDOUS LOCATION, CSA
B THIS DOCUMENT IS THE PROPERTY OF MERCURY INSTRUMENTS. IT IS TO BE KEPT UNCLASSIFIED AND UNCONTROLLED UNLESS OTHERWISE INDICATED BY THE ADDRESS, CARRIER OR LABEL OR USED FOR OTHER PURPOSES WITHOUT THE EXPRESS WRITTEN CONSENT OF MERCURY INSTRUMENTS.	A
REV REV. 10/2008	DATE 10/2008
REV REV. 10/2008	DATE 10/2008
REV REV. 10/2008	DATE 10/2008
REV REV. 10/2008	DATE 10/2008
REV REV. 10/2008	DATE 10/2008

ESD HANDLING PRECAUTIONS

Any electronics device contains components sensitive to ESD (electrostatic discharge). For example people experience up to 35kV ESD, typically while walking on a carpet in low humidity environments. In the same manner many electronic components can be damaged by less than 1000 volts of ESD. For this reason you must observe the following handling precautions when servicing this equipment:

- 1) Always wear a conductive wrist strap.
- 2) Eliminate static generators (plastics, Styrofoam, and so on) in the work area.
- 3) Remove nylon or polyester jackets, roll up long sleeves, and remove or tie back loose hanging neckties, jewelry, and long hair.
- 4) Store and transport all static sensitive components in ESD protective containers.
- 5) Disconnect all power from the unit before ESD sensitive components are removed or inserted, unless noted.
- 6) Use a static safeguarded workstation, which can be set up by using an anti-static kit (Motorola part number 0180386A82). This kit includes a wrist strap, two ground cords, a static control tablemat, and a static control floor mat. The Motorola part number for a replacement wrist strap that connects to the tablemat is 4280385A59.
- 7) When anti-static facilities are unavailable, use the following technique to minimize the chance of damaging the equipment:
- 8) Let the static sensitive component rest on a conductive surface when you are not holding it.
- 9) When setting down or picking up the static sensitive component, make skin contact with a conductive work surface first and maintain this contact while handling the component.
- 10) If possible, maintain relative humidity of 70-75% in development labs and service shops. Less humidity is more conducive towards static charge buildup and subsequent discharge.

SPECIFICATIONS

CERTIFICATIONS

- Measurement Canada (metrology for CNI2e-H only) AG-0618 issued 24-FEB-2016
- FCC, CFR, Title 47, Chapter I, Part 15 Subpart B (USA)
- ICES-003, Issue 4, 2004 (Canada)
- FCC Parts 22, 24 (inherited from the radio module)
- PTCRB for the North American GSM & HSPA networks
- CCF for the North American CDMA/1X networks
- CSA Certificate 2275314

CELLULAR CARRIER CERTIFICATIONS

The CNI2e-H is permitted to operate with the following cellular network carriers.

- Rogers (Canada), GSM / GPRS and WCDMA/HSPA
- Telus (Canada), GSM / GPRS and WCDMA/HSPA
- Bell Mobility (Canada), GSM / GPRS and WCDMA/HSPA
- T-Mobile-USA, GSM / GPRS
- AT&T, GSM / GPRS and WCDMA/HSPA

The CNI2e-C is permitted to operate with the following cellular network carriers.

- Aeris, CDMA / 1XRTT
- Verizon Wireless, CDMA / 1XRTT

MECHANICAL

Operational Temperature range

-22 °F to 158 °F (-30 °C to 70 °C)

Environmental Ratings

The CNI2e assemblies are not weather-resistant. They must be mounted inside another enclosure suitable for outdoor use.

Humidity Range

5 - 95% R.H. non-condensing. If the product is to be retained in storage for any length of time, it is recommended that the humidity range be maintained between 10 - 70% R.H., non-condensing.

J9, J12 Connector (CNI2e-C only)

Purpose: Allows access to Input / Output Lines-9 & 10.
Connector Type: 2-Pin MTA with 2.54 mm (0.1") spacing.
Connector Mate: Recommended mating connector is AMP/TYCO 641190-2.

AMP/TYCO
641190-2

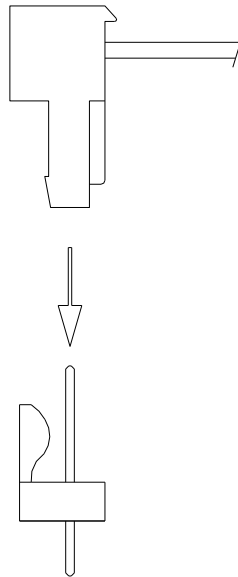

J9 and J12 Connectors on the CNI2e-C

J7, J11 Connector (CNI2e-C only)

Purpose: Allows access to Input / Output Lines-11 & 12.
Socket: RIA Connect Type 373, 2-position, Part number P/N 313731-02
Plug-in Terminal Block: RIA Connect Type ASP051, 2-position, Part number P/N ASP051-2
Wire Gauge: 20-28 AWG (0.08-0.5 mm²) Spacing is 0.098" (2.5 mm).

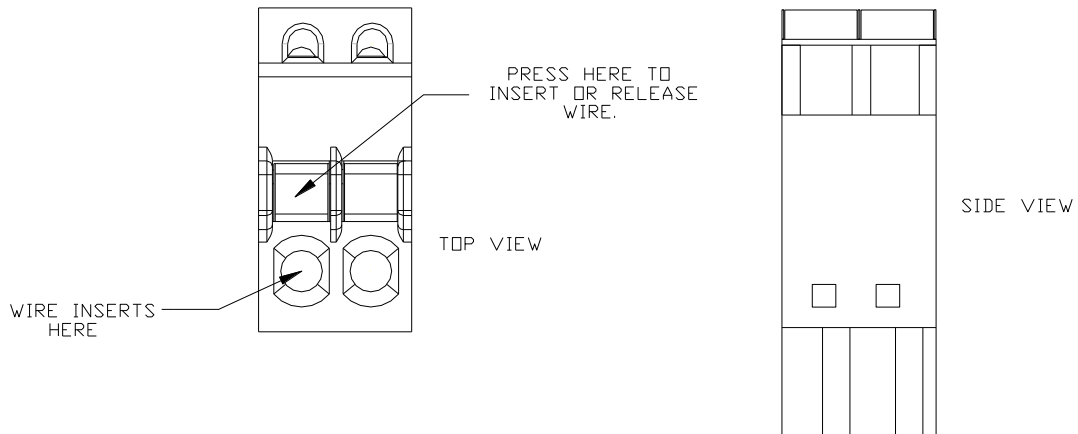

J7 and J11 Connectors on the CNI2e-C

TB4 Connector (CNI2e-C only)

Purpose: Allows access to Input / Output Lines-1 & 2.
Socket: RIA Connect Type 343, 4-position, Part number P/N 313431-04
Plug-in Terminal Block: RIA Connect Type 339, 4-position, Part number P/N 313391-04
Wire Gauge: 16-28 AWG (0.08-1.5 mm²) Spacing is 0.189" (3.5 mm).

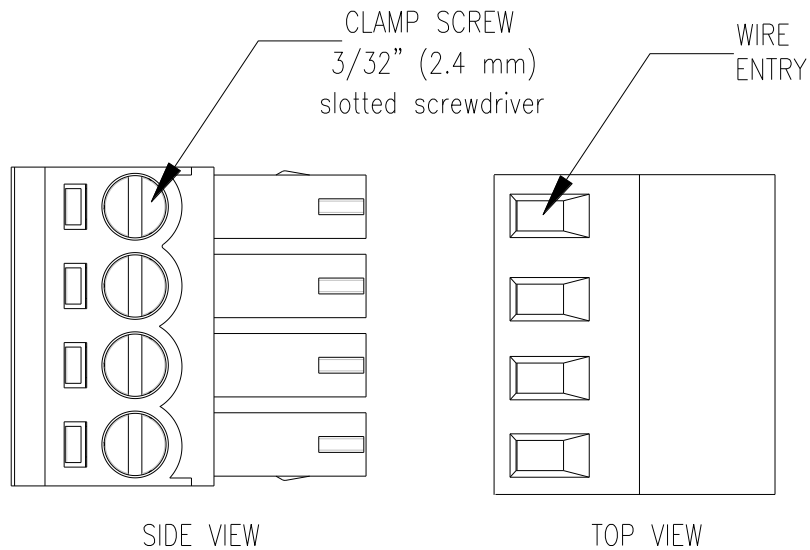

TB4 Plug on CNI2e-C

TB2, TB3 Connector (CNI2e-H only)

Purpose: Allows access to Input / Output Lines-1,2,9,10,11,12.
Socket: RIA Connect Type 343, 6-position, Part number P/N 313431-06
Plug-in Terminal Block: RIA Connect Type 339, 6-position, Part number P/N 313391-06
Wire Gauge: 16-28 AWG (0.08-1.5 mm²) Spacing is 0.189" (3.5 mm).

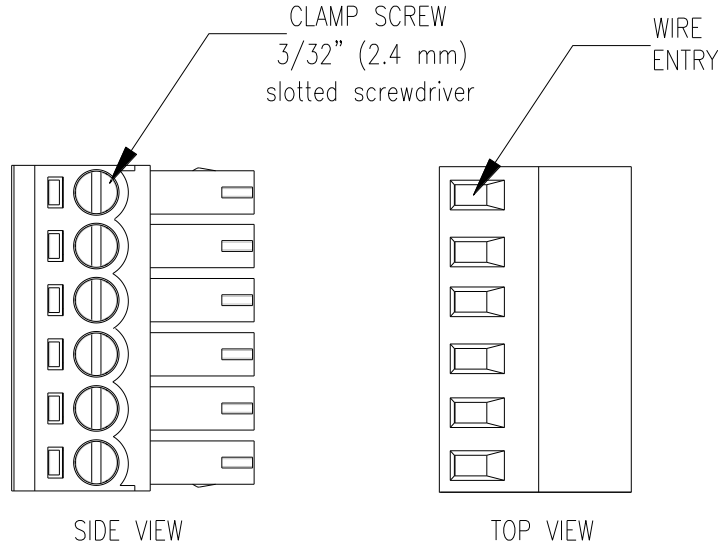

TB2 and TB3 Plug on CNI2e-H

Serial Port Connector (TxD, RxD, GND)

Purpose: Allows access to Serial Port Signals TxD, RxD and GND.
Socket: RIA Connect Type 343, 3-position, Part number P/N 313431-03
Plug-in Terminal Block: RIA Connect Type 339, 3-position, Part number P/N 313391-03
Wire Gauge: 16-28 AWG (0.08-1.5 mm²) Spacing is 0.189" (3.5 mm).

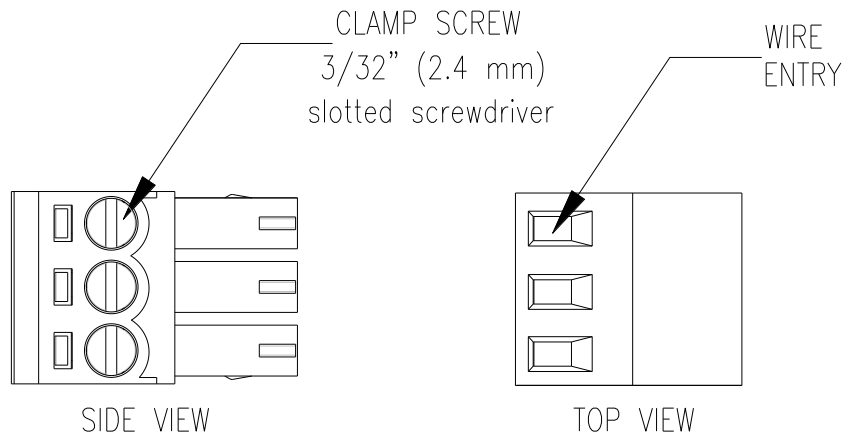

Serial Port Plug (short)

Serial Port Connector (DCD, DSR, DTR)

Purpose: Allows access to all Serial Port Signals except TxD, RxD and GND.
Socket: RIA Connect Type 343, 7-position, Part number P/N 313431-07
Plug-in Terminal Block: RIA Connect Type 339, 7-position, Part number P/N 313391-07
Wire Gauge: 16-28 AWG (0.08-1.5 mm²) Spacing is 0.189" (3.5 mm).

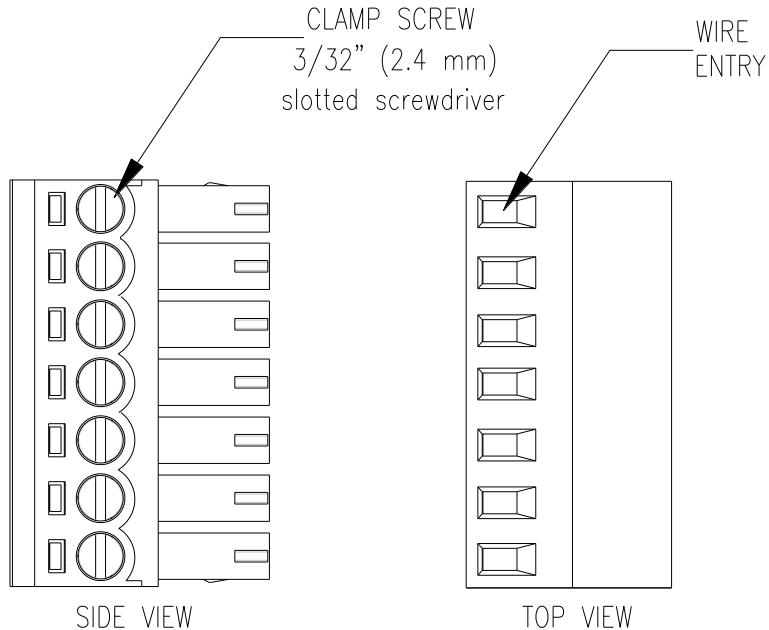

Serial Port Plug (long)

J1 and J2 Power Connectors

Purpose: Allows 4-28Vdc power source to be connected to J1 and/or J2.
Socket: JST 3-Position shrouded header, 2.5mm, P/N B3B-XH-A-LF
Plug Housing: JST XHP- 3
Contacts: JST SXH-001T-P0.6 (two required)
Wire Gauge: 22-28 AWG (0.08mm-0.33mm)

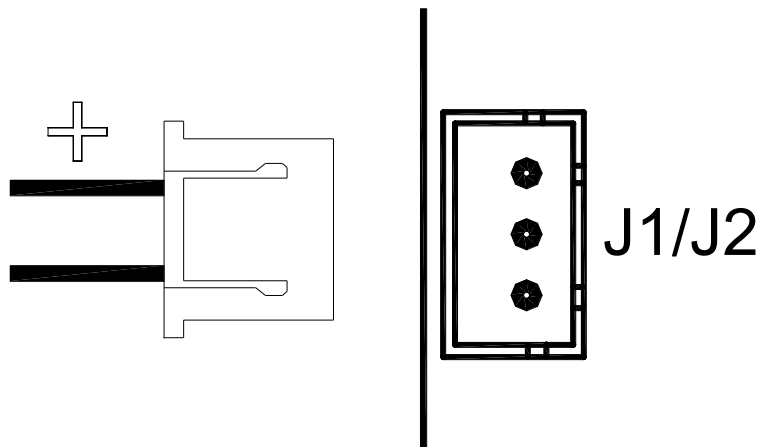

TB1 Power Input Terminal Block

Screw terminal, 5.08 mm (0.2") spacing. 90° entry. 14-26 AWG (0.14 – 1.5 mm²) wire size. Maximum torque is 0.6 Nm (5.3 lbs.-in). See next illustration for polarity.

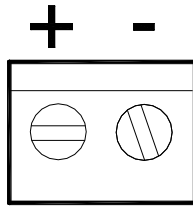

TB1

TB1 Power Terminal Block

Circuit Board Mounting Holes

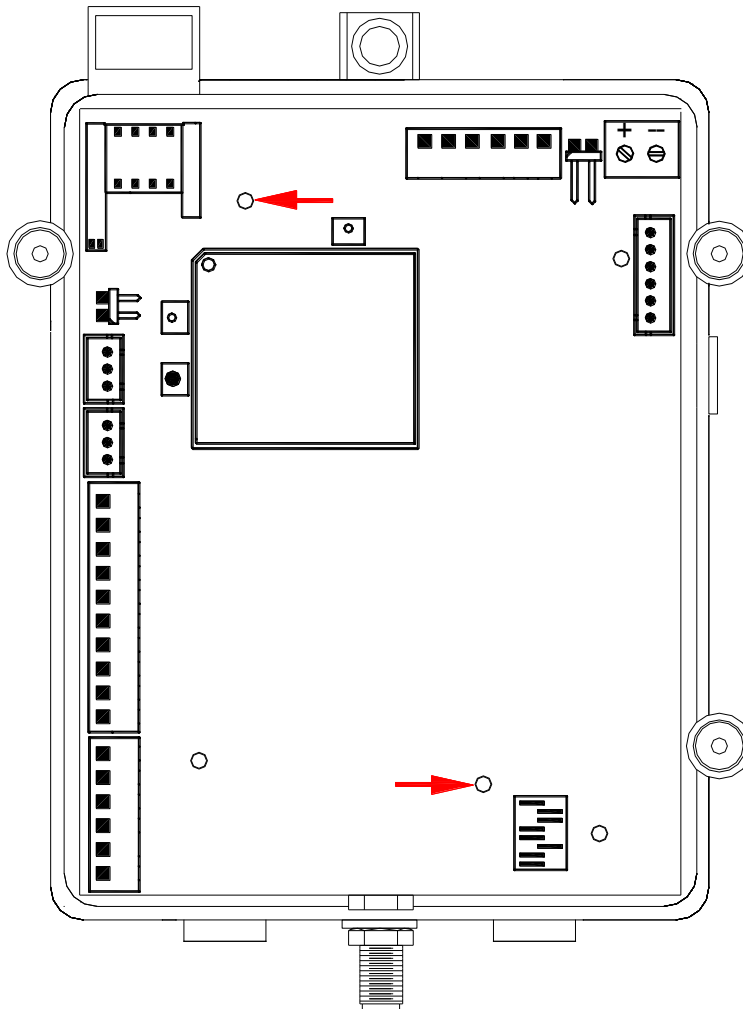

PCA Mounting Hole Locations

ELECTRICAL - POWER

Input Voltage Range

4.0 – 28.0 Vdc at J1, J2 and/or TB1.

Peak Current Requirements during Transmission

GSM, HSPA: During transmission the average current is 300 mA but peak currents can be as high as 2.0 amps for a duration of 0.5 milliseconds every 4.5 milliseconds.

CDMA: During transmission the maximum current draw can be as high as 800 mA.

Sleep current

< 350 μ A (Operating as Metretek SIP, pulse-counting on 2 channels, alarm-sensing on 2 channels, 50 samples/sec.)

Boost (Super) Capacitor

Connects to the TB1 terminal block and assists the battery pack during peak current events, usually during radio transmission. See the section titled "[Use of a SuperCapacitor](#)" for specific information, limitations and warnings.

Low-Voltage Detector

Measured at the TB1, J1 and J2 power connectors, whichever has the highest voltage. The user can define a low-voltage alarm point in the range of 0.1 – 28 Vdc.

During "sleep" mode the power inputs are measured every 5 minutes. If four consecutive readings are below the user-defined alarm point, a low-battery condition is logged and reported. If "Power Preservation Mode" is enabled, the time between measurements is reduced to 2 minutes.

During "run" mode (radio powered up) the power inputs are measured every 0.2 seconds. If all readings are below the user-defined alarm point for a period of 2 minutes, a low-battery condition is logged and reported.

Radio Module Power

Typically 3.7 – 3.8Vdc, generated by a SEPIC regulator. On the CNI2e-C only this signal is connected to the serial port terminal block (TB2). It is current-limited with a replaceable 250 mA fuse (Littelfuse 251-250 or equivalent). This signal is present only when the radio is powered up.

Logic Voltage

Typically 3.2 – 3.4Vdc. On the CNI2e-H only this signal is connected to the serial port terminal block (TB2). It is current-limited with a 100 Ω resistor and should only be used as a reference voltage for interfacing purposes.

Approved Battery Pack Assemblies

- 40-5170 Dual cell lithium, disposable configuration.
- 40-3444-1 Quad cell lithium, disposable configuration.
- 40-3503-1 Quad cell alkaline molded plastic assembly (replaceable cells).
- 40-2596-1 Quad cell alkaline disposable configuration.
- 40-5551-1 Quad cell lithium, disposable (used for backup applications)

ELECTRICAL - GENERAL

Pulse Count (Time-Tagged Interval) Memory

User-selectable between 32K (which is actually 32768 bytes) or 60K (which is actually 61440 bytes). Total number of records that can be stored varies with the configuration.

As a Metretek SIP each pulse-counting channel requires 2 bytes per record.

As a Mercury Mini-Max or Pulse Accumulator the total number of records depends on the number of audit trail items being requested. See the Chapter entitled "[Mercury Emulation](#)" for exact details.

Flash Program Memory

116k bytes. Holds operating system and configuration values.

Static RAM Memory

8k bytes.

Clocks

Main frequency: 15.360 MHz

Time keeping frequency: 32.768 kHz

"Sleep" frequency: 200 kHz nominal (internal oscillator), bursting to 15 MHz during input sample periods in data logger mode.

ELECTRICAL – DIGITAL OUTPUTS

Number of outputs

Six outputs are available if not being used as inputs.

Output Configuration

Push-pull (“logic”), +3.3V, 2 mA max. Programmable as normally low or normally high. Source resistance = 100Ω. Outputs clamped to 3.3V.

On the CNI2e-H only Line-12 can be configured to be a push-pull or dry contact (open-collector) output. See the diagram below for the proper jumper settings

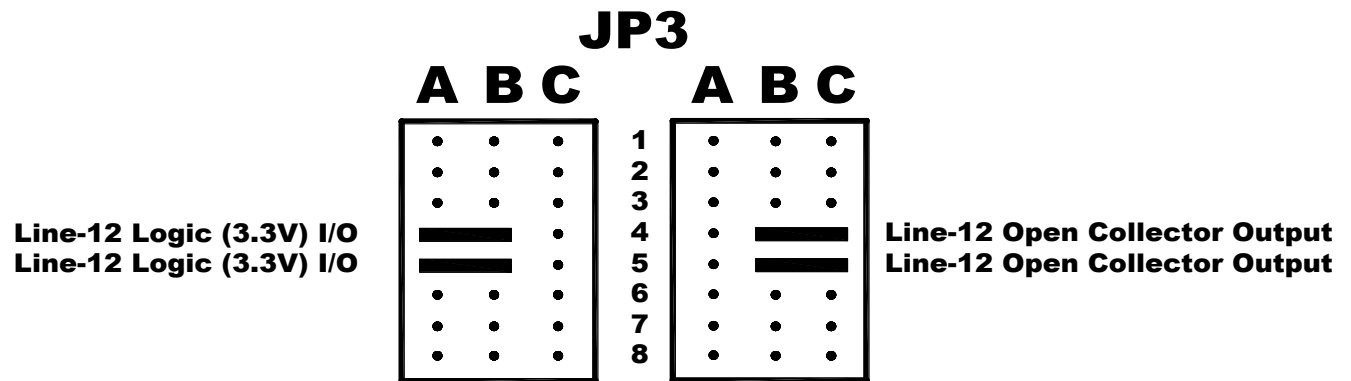

CNI2e-H Line-12 Configuration Jumpers

Output Configuration (Line-12 on the CNI2-H only)

Isolated dry-contact (open collector), 28 Vdc maximum wetting voltage, 25 mA maximum current.

See the diagram above for the proper jumper settings

Output Operating Modes

Up to three outputs can be changed remotely using PowerSpring® data collection system and with the CNI2e configured as a Metretek SIP.

Any output can be configured to follow an input.

One output can be configured to control external power sources when the radio is powered up.

Recommended Output Cable

Alpha 6300/4, Belden 9534, or equivalent having less than 100pF/ft capacitance. This cable type is 24awg, shielded, and has a PVC jacket. Terminate only one end of the cable shield to signal common or ground. Maximum cable length run should not exceed 1000 feet. Other cable types or gauges can be also be used as long as careful consideration is given to suitable wiring practices and performance.

ELECTRICAL – DIGITAL INPUTS

Number of inputs

Six inputs are available if not being used as outputs.

Input Configuration

Form-A or Form-B (independently configurable). Two inputs can be paired for Form-C operation.

On the CNI2e-H only the JP3 configuration jumpers must be set as seen here to use Line-12 as an input.

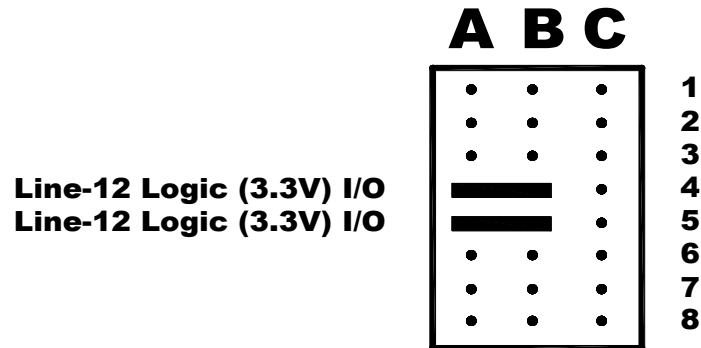

CNI2e-H Line-12 Input Configuration Jumpers

Input rate (sampling mode)

10 Hz maximum

Minimum input pulse width (sampling mode)

25 mS.

Sample rate (sampling mode)

1 – 50 samples per second (applies to all 6 inputs). Sample rate is user-selectable. A value of 0 selects edge-detection mode.

Debounce Count (sampling mode)

Number of samples needed to declare an input valid. This is user-selectable and each input is independently configurable. For instance if the sample rate is 4 samples per second, and the debounce value is set to 20, then the signal must be in the same state for 20 consecutive samples to be declared valid, which would be for a period of 5 seconds. Debounce values are ignored in edge-detection mode.

Input rate (edge-detection mode)

TBD Hz maximum

Minimum pulse width (edge-detection mode)

TBD mS.

Wetting current per input

33 μ A nominal.

Wetting voltage

www.Honeywellprocess.com

MNL-CNI2e

+3.3V nominal.

Input resistance

100Ω

Recommended Input Cable

Alpha 6300/4, Belden 9534, or equivalent having less than 100pF/ft capacitance. This cable type is 24awg, shielded, and has a PVC jacket. Terminate only one end of the cable shield to signal common or ground. Maximum cable length run should not exceed 1000 feet. Other cable types or gauges can be also be used as long as careful consideration is given to suitable wiring practices and performance.

ELECTRICAL – SERIAL PORT

Number of input lines

Two (2), RXD receive data and DTR handshake

Input levels

DTR: ±15V max.

RXD: ±15V max (EIA mode) or +3.3V/0V max (UART mode).

Number of output lines

Three (3) with EIA / RS-232 levels: TXD transmit data, DCD and DSR handshake lines.

Three (3) with non-inverted logic (3.3V) levels: TXD_U transmit data, DCD_U and DSR_U handshake lines.

Output levels

±5.5V max for EIA / RS-232 signals.

+3.3V / 0V max for logic-level (UART) signals, 100Ω source resistance.

Bit rate

300 to 115200 (user-selectable)

FUNCTIONAL

Modes of Operation

- Metretek “SIP” Pulse Accumulator, 1 – 4 channels, direct into PowerSpring® data collection system.
- Metretek “SIP” Pulse Accumulator via InvisiConnect®, 1 – 4 channels, indirect into PowerSpring® or MV90® data collection systems.
- Mercury Instruments “Mini-Max” (pulse accumulation only) or “PA” (Pulse Accumulator) direct to PowerSpring®, AutoSol® or MV90® data collection systems.
- Simple transparent modem (CSD or IP)
- SMS Modem (used to transmit SMS messages from InvisiConnect®).

Cellular Network Communications Options (varies with model and carrier support)

- CSD Mobile Terminate
- CSD Mobile Originate
- TCP/IP Client
- TCP/IP Server

Paging Mechanisms

- Short message service (SMS)
- Voice call (does not support voice transmission)

Status Indicators

- Two LEDs, red and green. Various patterns displayed to indicate connection status, cellular network status and error codes.

Firmware and Configuration Programming

- Via the programming connector using a USB or RS-232 Programming cable and MP32 software.
- Over-the-air programming via PowerSpring® data collection system and MP32 software.
- Over-the-air programming via InvisiConnect® and MP32 software
- Via RS-232 port using Masterlink® software (limited configuration changes only).

CELLULAR RADIO AND ANTENNA INFORMATION

CNI2e-H

Cinterion/Gemalto Model PHS8-P GSM/HSPA Module,
FCC ID # QIPPHS8-P, IC ID # 7830A-PHS8P

Receive Frequencies

Band-5	GSM, WCDMA	869-894 MHz
Band-8	GSM, WCDMA	925-960 MHz
Band-3	GSM, WCDMA	1805-1880 MHz
Band-2	GSM, WCDMA	1930-1990 MHz
Band-1	WCDMA	2110-2170 MHz

Transmit Frequencies

Band-5	GSM, WCDMA	824-849 MHz
Band-8	GSM, WCDMA	880-915 MHz
Band-3	GSM, WCDMA	1710-1785 MHz
Band-2	GSM, WCDMA	1850-1910 MHz
Band-1	WCDMA	1920-1980 MHz

Antenna Connector

SMA-Female, 50 ohm impedance.

CNI2e-C

Telit Model c24 CDMA/1X Module, FCC ID # RI7P56JE1

Receive Frequencies

Band-5	CDMA	869-894 MHz
Band-2	CDMA	1930-1990 MHz

Transmit Frequencies

Band-5	CDMA	824-849 MHz
Band-2	CDMA	1850-1910 MHz

Antenna Connector

SMA-Female, 50 ohm impedance.

ASCII CHART

Dec	Hex	Char	Dec	Hex	Char	Dec	Hex	Char	Dec	Hex	Char
0	00	Null	32	20	Space	64	40	@	96	60	`
1	01	Start of heading	33	21	!	65	41	A	97	61	a
2	02	Start of text	34	22	"	66	42	B	98	62	b
3	03	End of text	35	23	#	67	43	C	99	63	c
4	04	End of transmit	36	24	\$	68	44	D	100	64	d
5	05	Enquiry	37	25	%	69	45	E	101	65	e
6	06	Acknowledge	38	26	&	70	46	F	102	66	f
7	07	Audible bell	39	27	'	71	47	G	103	67	g
8	08	Backspace	40	28	(72	48	H	104	68	h
9	09	Horizontal tab	41	29)	73	49	I	105	69	i
10	0A	Line feed	42	2A	*	74	4A	J	106	6A	j
11	0B	Vertical tab	43	2B	+	75	4B	K	107	6B	k
12	0C	Form feed	44	2C	,	76	4C	L	108	6C	l
13	0D	Carriage return	45	2D	-	77	4D	M	109	6D	m
14	0E	Shift out	46	2E	.	78	4E	N	110	6E	n
15	0F	Shift in	47	2F	/	79	4F	O	111	6F	o
16	10	Data link escape	48	30	0	80	50	P	112	70	p
17	11	Device control 1	49	31	1	81	51	Q	113	71	q
18	12	Device control 2	50	32	2	82	52	R	114	72	r
19	13	Device control 3	51	33	3	83	53	S	115	73	s
20	14	Device control 4	52	34	4	84	54	T	116	74	t
21	15	Neg. acknowledge	53	35	5	85	55	U	117	75	u
22	16	Synchronous idle	54	36	6	86	56	V	118	76	v
23	17	End trans. block	55	37	7	87	57	W	119	77	w
24	18	Cancel	56	38	8	88	58	X	120	78	x
25	19	End of medium	57	39	9	89	59	Y	121	79	y
26	1A	Substitution	58	3A	:	90	5A	Z	122	7A	z
27	1B	Escape	59	3B	;	91	5B	[123	7B	{
28	1C	File separator	60	3C	<	92	5C	\	124	7C	
29	1D	Group separator	61	3D	=	93	5D]	125	7D	}
30	1E	Record separator	62	3E	>	94	5E	^	126	7E	~
31	1F	Unit separator	63	3F	?	95	5F	_	127	7F	□

ASCII Conversion Chart

Find Out More:

To learn more contact your
Honeywell Process Solutions representative,
visit www.Honeywellprocess.com or call 302-669-4253.

Performance Materials and Technologies

Honeywell Process Solutions
Process Measurement and Control
1280 Kemper Meadow Dr. Cincinnati, OH 45240 USA
Phone 302-669-4253 • Toll Free 855-251-7065

Honeywell

© 2015 Honeywell

www.Honeywellprocess.com

MNL-CNI2e