

Overview



The SITRANS RD100 is a 2-wire loop powered, NEMA 4X enclosed remote digital display for process instrumentation.

Benefits

- Easy setup
- Approved for hazardous locations
- NEMA 4X, IP67 impact-resistant enclosure
- Simple two-step calibration
- Two modes of input allow for easy servicing, with no interruption of loop required

Application

The RD100 is very versatile. It can be installed indoors or outdoors, in hot or cold environments, and in safe or hazardous areas.

It has been approved by FM and CSA as Intrinsically Safe and non-incendive, and operates from -40 to +85 °C (-40 to +185 °F), adding only 1 V to the loop.

Calibration consists of a quick two-step process involving the adjustment of only two non-interacting potentiometers.

- Key Applications: remotely displays process variables in level, flow, pressure, temperature, and weighing applications, in a 4 to 20 mA loop.

Technical specifications

Mode of operation	
Measuring principle	Analog to digital conversion
Measuring range	4 ... 20 mA
Measuring points	1 instrument only
Accuracy	
	± 0.1 % of span ± 1 count
Rated operating conditions	
Ambient conditions	
• Operating temperature range	-40 ... +85 °C (-40 ... +185 °F)
• Storage temperature	-40 ... +85 °C (-40 ... +185 °F)
Design	
Weight	340 g (12 oz)
Material (enclosure)	Impact-resistant glass filled polycarbonate body and clear polycarbonate cover
Degree of protection	NEMA 4X, IP67
Power supply	
External loop power supply	30 V DC max.
Display	
	<ul style="list-style-type: none"> • 1.0 inch (2.54 cm) high LCD • Numeric range from -1 000 ... +1 999
Certificates and approvals	
Non-hazardous	CE
Hazardous	
• Intrinsically Safe	<ul style="list-style-type: none"> • CSA/FM Class I, II, III, Div. 1, Groups A, B, C, D, E, F, G T4 • CSA/FM Class I, Zone 0, Group IIC • CSA/FM Class I, Div. 2, Groups A, B, C, D • CSA/FM Class II and III, Div. 2, Groups F and G
• Non-incendive	
Options	
Mounting	<ul style="list-style-type: none"> • 2 inch (5.08 cm) pipe mounting kit (zinc plated or stainless steel) • Panel mounting kit

Selection and ordering data

	Article No.
SITRANS RD100 Display	7ML5741-
Remote digital display for process instruments. 2-wire, loop powered, NEMA 4X enclosure.	A 0 0 - 0
Click on the Article No. for the online configuration in the PIA Life Cycle Portal.	
Conduit hole location (½ inch)	
None	1
Bottom	2
Rear	3
Top	4
Approvals	
FM/CSA	A
CE	B
Selection and Ordering data	Article No.
Operating Instructions	
All literature is available to download for free, in a range of languages, at http://www.siemens.com/processinstrumentation/documentation	
Accessories	
Panel mount kit	7ML1930-1BN
2 inch (5.08 cm) pipe mounting kit (zinc plated seal)	7ML1930-1BP
2 inch (5.08 cm) pipe mounting kit (stainless steel, Type 304, EN 1.4301)	7ML1930-1BQ

Supplementary components

Displays

SITRANS RD100

Dimensional drawings

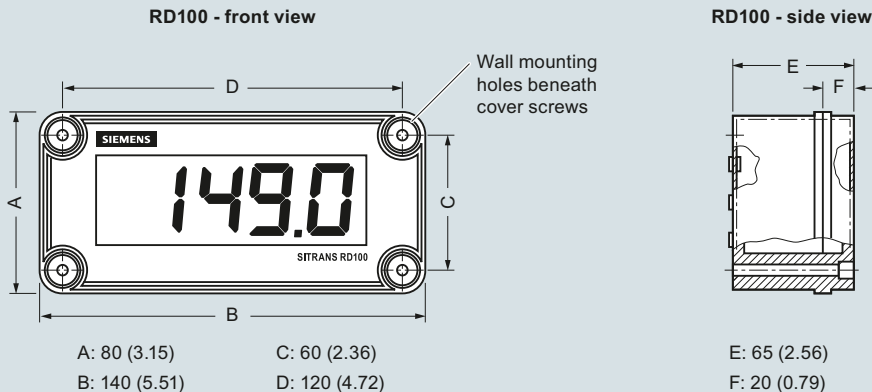

SITRANS RD100, dimensions in mm (inch)

Circuit diagrams

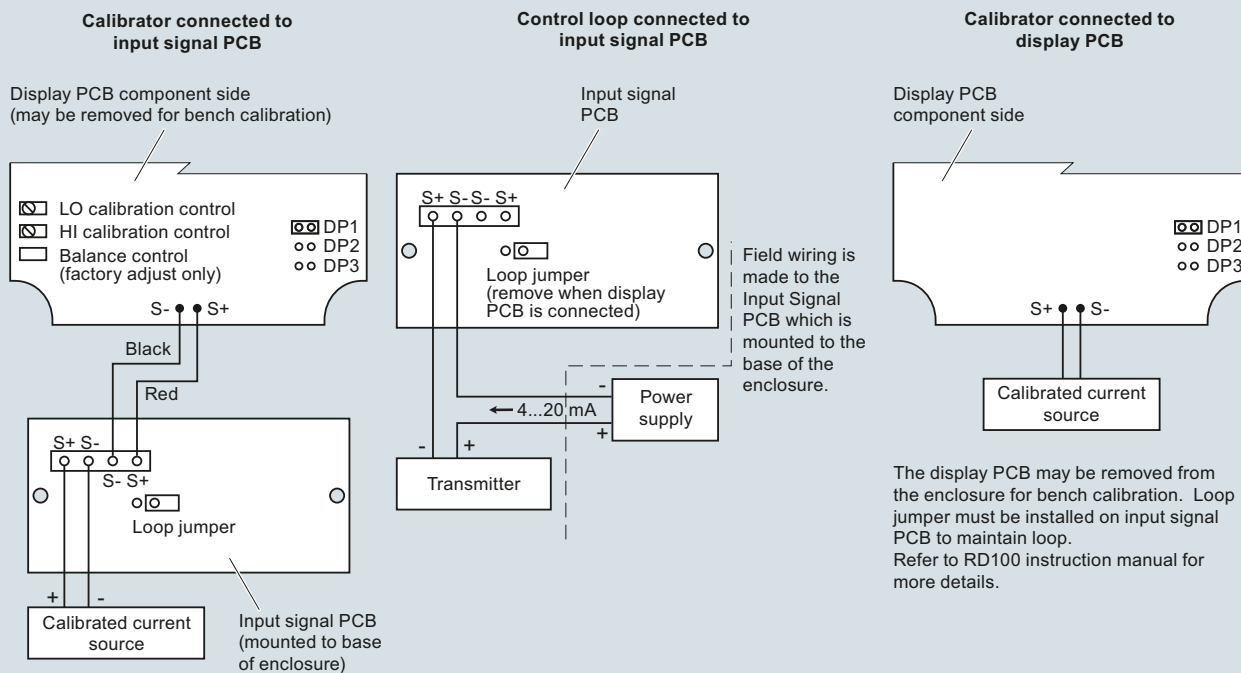

CE version

